

Three-Phase Isolated Boost DC-DC Converter for High Voltage Applications

R.Samuel Rajesh Babu (Corresponding author)

Research scholar, EEE Department
Sathyabama University, Chennai, India.
E-mail: Samuel.rajeshbabu@gmail.com

Joseph Henry

Professor, EEE Department,
Vel Tech University, Chennai, India.
E-mail: joseph_henry@rediffmail.com

Abstract

The voltage fed DC-DC converter has been suffering from problems associated with large transformer leakage inductance due to high transformer turn ratio when it is applied to low-voltage, high-current step-up application such as fuel cells. This paper proposes a new three-phase voltage fed DC-DC converter, which is suitable for high-voltage, high-current applications. The transformer turn ratio is reduced to half owing to Δ -Y connection. The zero-voltage and zero-current switches (ZVZCS) for all switches are achieved over wide load range without affecting effective duty cycle. A clamp circuit not only clamps the surge voltage but also reduces the circulation current flowing in the high-current side, resulting in significantly reduced conduction losses. The duty cycle loss can also be compensated by operation of the clamp switch. The detailed design and operating principles are described and simulated using Pspice. The proposed converter is very attractive for electrolyser application.

Keywords: High power DC-DC converter, three-phase DC-DC converter, active clamp circuit, Isolation transformer

1. Introduction

High-frequency transformers are usually involved in the DC-DC converter for boost as well as galvanic isolation and safety purpose. The single-phase DC-DC converter based on the push-pull [1] or full-bridge [2]-[3] topology has been used as an isolated boost DC-DC converter for less than several Kilowatt power levels. For higher power level, the single-phase converter could suffer from severe current stresses of the power components.

The DAB can achieve ZVS on both high- and low-side switches and has no inductors involved in the power circuit. However, the DAB has many active switches and high ripple currents. Also, the VA rating of the transformer is comparably large, and manufacturing of the high-frequency transformer with large leakage inductance is a challenging issue.

The three-phase DC-DC converter has been proposed as an alternative for high-power application. The three-phase DC-DC converter has several advantages over the single phase DC-DC converter such as easy MOSFETs selection due to reduced current rating, reduction of the input and output filter's volume due to increased effective switching frequency by a factor of three compared to single-phase DC-DC converter, reduction in transformer size due to better transformer[4] utilization. The three-phase isolated boost DC-DC converter can be classified to dual active bridge (DAB) converters, current fed converters and voltage-fed converters.

The voltage-fed DC-DC converter has also been used in High voltage applications. An important advantage of the voltage-fed type is *lower* switch voltage rating since the switch voltage is fixed to input voltage, and therefore MOSFETs with lower R_{ds} (ON) can be selected. This is critically beneficial in the fuel cell application where more than 50% of the power loss is lost as a switch conduction loss at the low-voltage side [5]. Also, the voltage-fed converter does not have a self-start problem unlike the current-fed converter. However, the voltage-fed converter suffers from a high transformer turns ratio, which causes large leakage inductance resulting in large duty cycle loss, [6] increased switch current rating, and increased surge voltage on the rectifier diode.

A clamping or snubber circuit is usually required for the current-fed converter to limit the transient voltage caused by transformer leakage inductance [7]. The current-fed converter is also lack of self-starting capability and, therefore, it necessitates an additional start-up circuitry [8]. The three phase current-fed DC-DC converter proposed for step-up applications [9] has only three active switches, but the active switches are hard switched and the passive clamping circuit on the high-current side may cause large amount of losses. The three-phase current-fed DC-DC converter with an active clamping circuit [10] not only clamps the surge voltage but also offers ZVS on the active switches. However, this scheme suffers from the high ripple current imposed on the clamp capacitor located at the high-current side.

The three-phase voltage-fed DC-DC converter, so-called V6 converter, proposed for step-up applications, [11] significantly mitigates the problem associated with high transformer turn ratio of the voltage-fed type by utilizing the open Δ -Y type transformer connection, which reduces the required turn ratio to half. Also, the size of the input filter capacitor to reduce the input current ripple is reduced, since the effective switching frequency is increased by three times due to the interleaved operation.

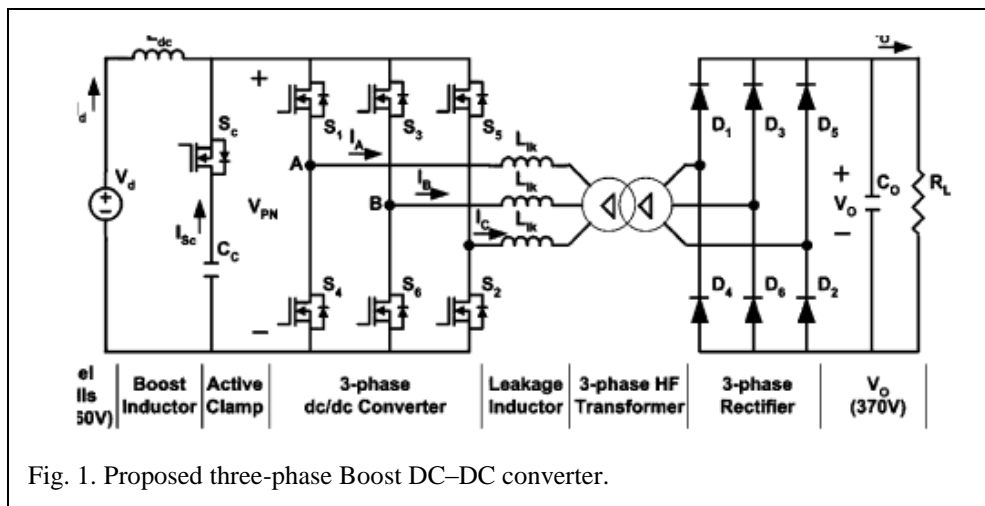

Fig. 1. Proposed three-phase Boost DC-DC converter.

In this paper, the turn ratio of the high-frequency transformer is reduced to half by employing the Δ -Y connection. A clamp circuit that is located at low-current, high-voltage side not only clamps the surge voltage but significantly reduces the circulating current flowing through high-current side, resulting in reduced switch conduction losses and transformer copper losses. A three-phase voltage-fed DC-DC converter for isolated boost application such as Electrolyser is proposed. Further, with the help of the clamp circuit zero-voltage and zero-current switching (ZVZCS) for all switches over wide load range is achieved. The duty cycle loss can also be compensated by the clamp switch. The operating principles and features of the proposed converter are illustrated and the simulation results validate the proposed concept.

Applications

Three-Phase Isolated Boost DC-DC converter will be widely used in various High voltage applications such as

1. Energy storage system with galvanic isolation
2. Traction drive of hybrid fuel cell system
3. Residential fuel cell generation
4. DC UPS and industrial applications
5. Aerospace power systems
6. Electric vehicles and battery chargers
7. Electrolyser system
8. High step-up applications

2. Operating Principles

As shown in Fig. 1, the proposed three-phase voltage-fed DC-DC converter includes six MOSFET switches. First, the Δ -Y transformer requires the smallest turn ratio for step-up application, and in fact the required turn ratio is half that of Y-Y or Δ - Δ transformers. The reduction of turn ratio significantly mitigates problems associated with large leakage inductance, which are large duty cycle loss, increased switch current rating, and surge voltage on the rectifier diode. This is a big advantage of the three-phase DC-DC converter over the single-phase dc-dc converter based on the push-pull or full bridge type and makes the voltage-fed DC-DC converter viable for high gain step-up application. Second, the Δ -Y configuration is also shown to have the smallest transformer kVA rating and switch current rating [11]. Six MOSFET switches and a clamp circuit consisting of a MOSFET switch and a capacitor at low-voltage side and a three-phase diode bridge, an LC filter at high-voltage side.

State 1 [$t_1 - t_2$]: S_1 , S_2 , and S_6 are conducting, and lower switches S_2 and S_6 are carrying half of upper switch S_1 current since two transformer primary currents become equal due to the current flow at the secondary. Since voltage across transformer leakage inductor V_{lk1} is a small negative value, which is a difference between the input voltage and half of the clamp capacitor voltage referred to the primary, transformer primary current I_{p1} is slowly decreasing. The transformer secondary winding current is also decreasing but larger than load current I_o during this mode. Therefore, clamp capacitor C_c is being charged through the body diode of S_c by the decreasing current.

State 2 [$t_2 - t_3$]: When clamp current I_{Sc} decreases to zero, the clamp branch is completely disconnected from the circuit. The input power is still being delivered to the output. Diodes D_1 and D_2 carry load current I_o through the transformer secondary windings. The voltages across the leakage inductors V_{lk1} is zero.

State 3 [$t_3 - t_4$]: S_1 is turned off at t_3 . External capacitor C_{ext} across S_1 is charged and parasitic capacitor C_{oss} of S_4 is discharged by reflected load current to the primary $2nI_o$. Switch voltage V_{S1} increases linearly with a slope of $2nI_o/(C_{ext} + 2C_{oss})$. The upper switch is almost turned off with ZVS if external capacitor C_{ext} is chosen large enough to hold the switch voltage at near zero at the switching instant. At the end of this mode, the body diode of S_4 is turned on.

State 4 [$t_4 - t_5$]: Lower switch S_4 is turned on with ZVS since V_{s4} became already zero at State 3. Turning on of the clamp switch at t_4 causes the rectifier voltage referred to the primary to be applied to the leakage inductor resulting in rapid decrease of the transformer primary current to zero, and this causes the clamp capacitor to discharge to supply the load. This reset operation eliminates the circulating current through the

transformer and switches, resulting in significantly reduced conduction losses. Note that the clamp is turned on with ZVS.

State 5 [$t_5 - t_6$]: At t_5 , the main switch current, transformer winding current, and diode current become zero, and the clamp capacitor fully supplies the load.

State 6 [$t_6 - t_7$]: Clamp switch S_c is turned off at t_6 , and the load current freewheels through all the diodes. The clamp switch can also be turned off with ZVS if capacitance across the clamp switch is properly chosen. The gate signal for lower switch S_6 is removed during this mode, and S_6 is turned off with ZCS.

State 7 [$t_7 - t_8$]: Upper switch S_3 is turned on at t_7 and S_2 , S_3 , and S_4 start conducting. Note that S_3 is turned on with ZCS since S_3 current linearly increases with a slope of V_{in}/L_{k1} . This causes commutation of diode currents, that is, increase of diode currents I_{D3} and I_{D4} and decrease of other diode currents. At the end of the commutation, the rectifier voltage is clamped by V_c through the body diode of S_c . This is the end of one-third of the cycle. The second part of the cycle is repeated in the same fashion.

Δ -Y

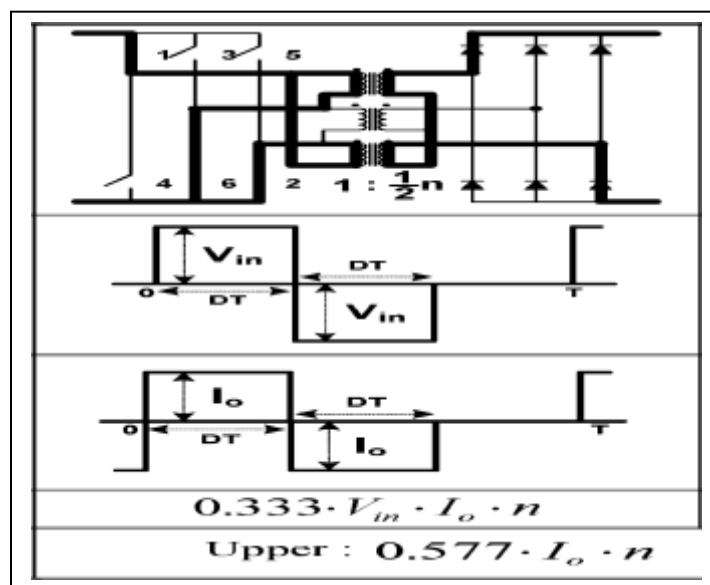

Fig. 2. Component rating according to transformer Connections (Δ -Y)

Y- Δ

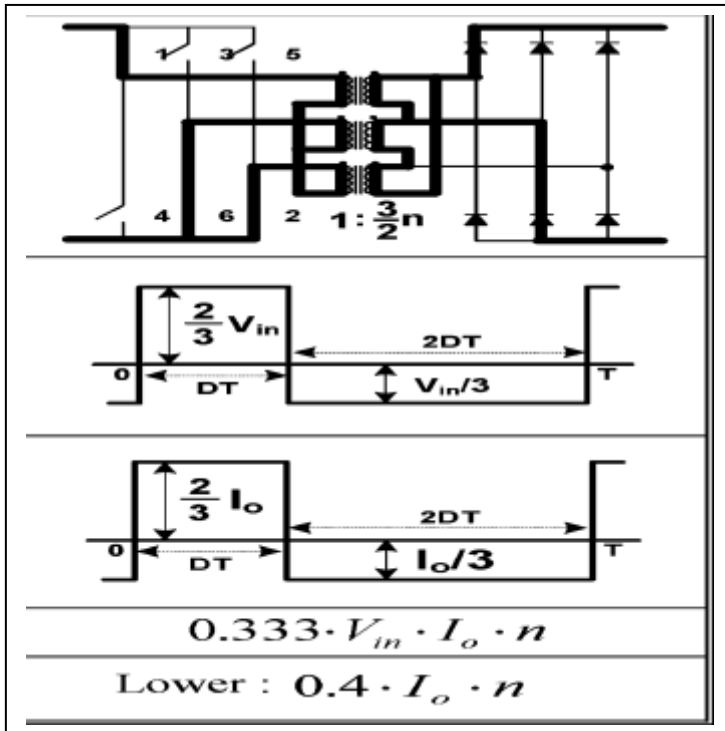

Fig. 3. Component rating according to transformer Connections (Y-Δ)

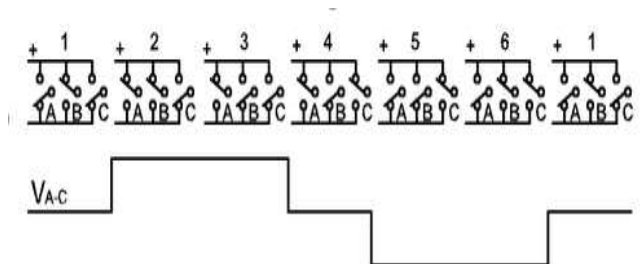
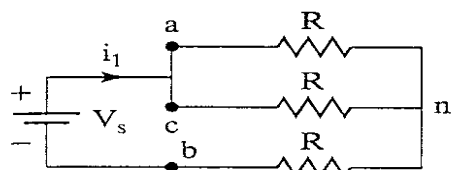

Fig. 4. Six-step switching sequence in 3-phase Inverters

MODE I OPERATION



Q_1, Q_5, Q_6 conduct

$$R_{eq} = R + \frac{R}{2} = \frac{3R}{2}$$

$$i_1 = \frac{V_s}{R_{eq}} = \frac{2V_s}{3R}$$

$$v_{an} = v_{cn} = \frac{i_1 R}{2} = \frac{V_s}{3}$$

$$v_{bn} = -i_1 R = -\frac{2V_s}{3}$$

MODE II OPERATION

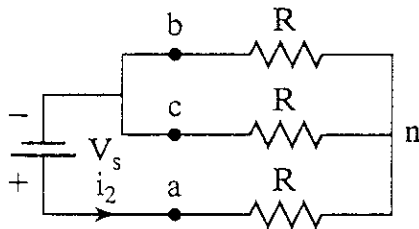

Q_1, Q_2, Q_6 conduct

MODE III OPERATION

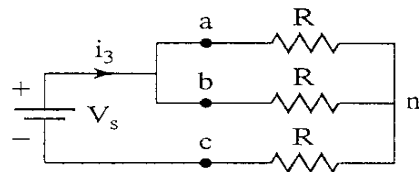

Q_1, Q_2, Q_3 conduct

In order to achieve ZCS turn-OFF of a lower switch, the primary circulating current should completely be reset before the upper switch turns on. Therefore, the required dead time for upper switches is determined by

$$t_{dead, U} \geq Lk \frac{4nI_o}{V_c}$$

ZCS turn-OFF range of the ZVZCS full-bridge converter is actually *restricted* by the maximum duty cycle since the required dead time of lagging leg switches is considerable in this low voltage, High-current application.

4. Simulation Results

Three-Phase Isolated Boost DC-DC Converter is simulated using Pspice and simulation results are presented.

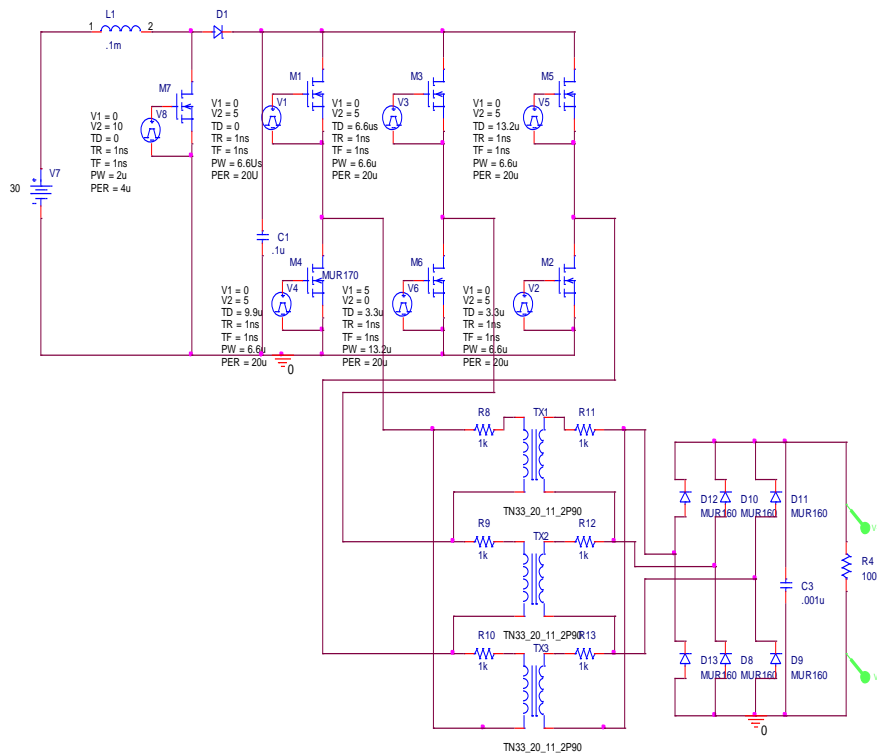

Fig 5.Simulated circuit diagram

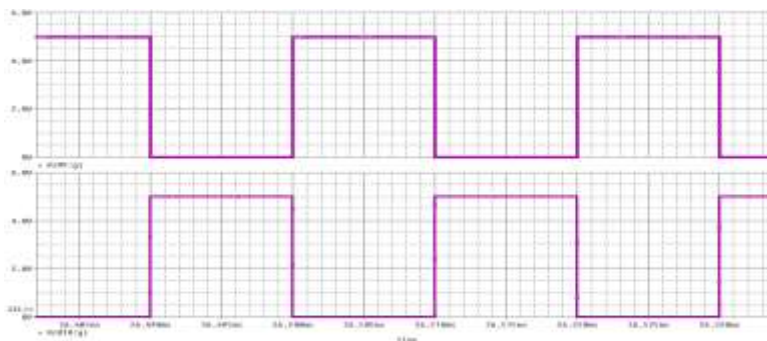

Fig 6.Gate pulse

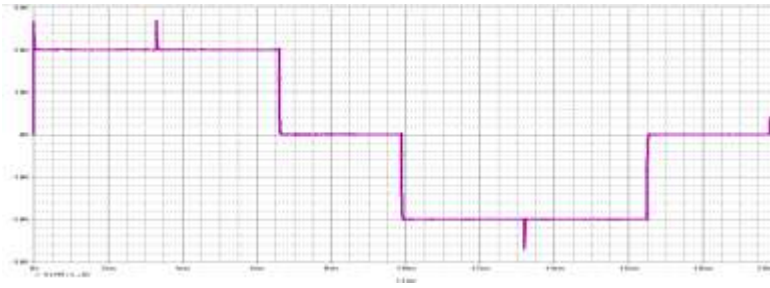

Fig 7.Three phase output waveform of inverter

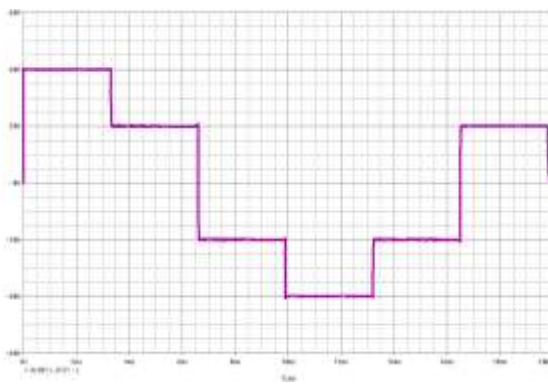

Fig 8.Phase to Phase output waveform of inverter

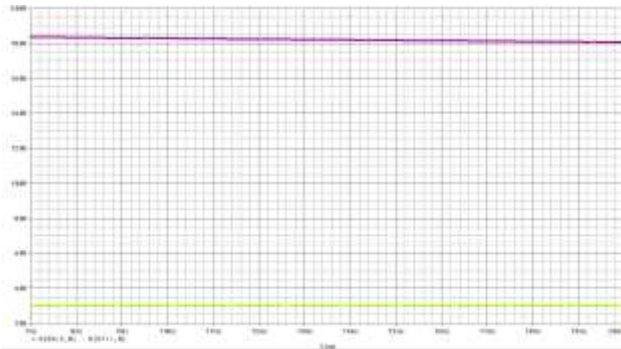

Fig 9.Input and output waveforms for proposed converter

CONCLUSION

In this paper, a new three-phase voltage-fed DC-DC converter for a high-voltage, step-up application has been proposed. The proposed converter has the following advantages:

1. The duty cycle loss is compensated by the clamp switch. These advantages make the proposed converter attractive for high-voltage, high-current step up application such as Electrolyser application, fuel cell power conditioning systems.

2. The required transformer turn ratio is as low as that of the current-fed converter due to the Δ -Y connection.
3. Circulating current through high-current side is removed due to the reset operation, resulting in significantly reduced conduction losses.

The proposed converter has advantages like fast current switching, low parasitic circuit inductance, very high efficiency, reduced switching losses, reduced switching stresses, reduced EMI, increased power density and high efficiency. The proposed converter is very attractive for High voltage applications.

References

- Montilva, J., Rivero, M., Barrios, J., Martinez, A., Besembel, I. & Sandia, B. (2010), "Professional Training Program Management through Holonic Networks", *CLEI Electronic Journal* **13**(2), paper 5.
- Redding (2004), "Power Plant Relief Operator", http://www.ci.redding.ca.us/personnel/class_spec/834.pdf [accessed 22 Aug 2011]
- Lee J, Jo J, Jang M, Choi S, Han S (2006), "A 10 KW SOFC low voltage battery hybrid power conditioning system for residential use", *IEEE Trans. Energy Convers.*, 21(2), 575–585.
- Oliveira DS, Jr, Barbi I (2005), "A three-phase ZVS PWM DC/DC converter with asymmetrical duty cycle for high power applications", *IEEE Trans. Power Electron.*, 20(2), 370–377.
- Lai JS(2005), "A high-performance V6 converter for fuel cell power conditioning system", in *Proc. IEEE VPPC*, 7.
- Cha H, Enjeti P(2007), "A novel three-phase high power current fed DC/DC converter with active clamp for fuel cells", in *Proc. IEEE PESC*, 2485–2489
- Andersen GK, Klumpner C, Kjaer SB, Laabjerg F(2003), "A new power converter for fuel cells with high system efficiency", *Int. J. Electron.*, 90(11–12), 737–750.
- Rathore AK, Bhat AKS, Oruganti R (2007), "A comparison of softswitched DC-DC converters for fuel cell to utility interface application", in *Proc. IEEE PCC*, 588–594.
- Moon SR, Jih-Sheng L(2007), "Multiphase isolated DC-DC converters for low-voltage high-power fuel cell applications", in *Proc. IEEE APEC*, 1010–1016.
- Oliveira SVG, Barbi I (2005), "A three-phase step-up DC-DC converter with a three-phase high frequency transformer", in *Proc. IEEE ISIE*;2,571–576.
- Oliveira DS, Jr, Barbi I (2005), "A three-phase ZVS PWM DC/DC converter with asymmetrical duty cycle for high power applications", *IEEE Trans. Power Electron.*; 20 (2)370–377.
- Cho JG, Jeong CY, Lee FC (1998), "Zero voltage and zero current switching full bridge PWM converter using secondary active clamp", *IEEE Trans. Power Electron.*; 13(4) 601–607.
- Mohr M, Fuchs FW (2006), "Voltage fed and current fed full bridge converter for the use in three phase grid connected fuel cell systems", in *Proc. IEEE IPEDMC*;1, 1–7.

This academic article was published by The International Institute for Science, Technology and Education (IISTE). The IISTE is a pioneer in the Open Access Publishing service based in the U.S. and Europe. The aim of the institute is Accelerating Global Knowledge Sharing.

More information about the publisher can be found in the IISTE's homepage:

<http://www.iiste.org>

The IISTE is currently hosting more than 30 peer-reviewed academic journals and collaborating with academic institutions around the world. **Prospective authors of IISTE journals can find the submission instruction on the following page:**

<http://www.iiste.org/Journals/>

The IISTE editorial team promises to review and publish all the qualified submissions in a fast manner. All the journals articles are available online to the readers all over the world without financial, legal, or technical barriers other than those inseparable from gaining access to the internet itself. Printed version of the journals is also available upon request of readers and authors.

IISTE Knowledge Sharing Partners

EBSCO, Index Copernicus, Ulrich's Periodicals Directory, JournalTOCS, PKP Open Archives Harvester, Bielefeld Academic Search Engine, Elektronische Zeitschriftenbibliothek EZB, Open J-Gate, OCLC WorldCat, Universe Digital Library, NewJour, Google Scholar

