

# **Adopting Successive Approximation Model For The Development Of Locally-Made Interventionary Manipulatives For The Teaching And Learning Of Mathematics In Basic Education Context: The Case Of Akrom M/A And Knust Primary Schools**

**Harry Barton Essel<sup>1</sup> Akosua Tachie-Menson<sup>2</sup> and Abraham Asuama Yeboah<sup>3</sup>**

*Art Education, Kwame Nkrumah University of Science and Technology<sup>1</sup>*

## **ABSTRACT**

*Manipulatives are concrete or virtual objects that enable pupils to visualize abstract mathematical concepts in concrete terms for easy comprehension. They play an important role in the success of effective mathematics education. Preliminary studies in the selected schools revealed that manipulatives were lacking in these schools and that made teaching and learning of some mathematics topics very challenging. This research sought to find out how mathematics is taught in the selected schools to establish the brunt on how the teaching and learning of mathematics is done with or without manipulatives. The two selected schools are public schools or government owned schools. The study is qualitative in nature employing the descriptive and quasi-experimental methods of research. The research instruments employed for the study were interview and observation. The accessible population for the study was 339. This was made up of 6 teachers, 199 teachers and 1 head teacher. The non-probability sampling techniques were employed specifically; convenient sampling was used to hand pick schools that were not too far from the researcher while the purposive sampling was used to judgmentally select the school that are been studied. Results from observation in both schools showed that, manipulatives were available for only addition and subtraction. Data from interviews showed that some topics in mathematics are challenging to teach without manipulatives. Successive Approximation Model (SAM) was used to design and develop mathematics manipulatives for five of the challenging topics to teach and learn which were tested in the selected schools to measure their effectiveness. The test scores revealed that pupil's academic experiences in those challenging mathematics topics improved with the use of manipulatives; pupils' participation in the classroom also improved drastically. It was recommended that, manipulatives should be available for all topics in mathematics to make teaching and learning easier and fun to improve academic performance of pupils in mathematics.*

## **INTRODUCTION**

Mathematics is a systematic body of knowledge that involves the sensible rational thought of “shape, quantity and arrangement”. Maths is in all that we do and forms the foundation of our lives from electronic gadgets, buildings that can be seen on the surface of the earth, construction, art, money and sports (Hom, 2013).

The National Council of Teachers of Mathematics (2000) as cited in J. Martinez and N. Martinez (2010) outlines that the study of mathematics allows students to arrange and put together figures and other mathematical symbols they find meaning to the exercises that they

are made to do, make use of it, examine and judge data that are used in solving problems. These exercises open up their minds and develop their mental acumen faster. Again, they believe that Mathematics develops in students the habit of asking questions and seeking answers to problems. This habit is developed from the fact that mathematics makes students engage in a whole lot of exercises that force students to ask questions and guess in their quest to find solutions to mathematical questions.

Effective teaching of mathematics cannot go on without effective teachers. Effective teachers are known to have certain characteristics that distinguish them from other teachers. Stipek et al (1998) as cited in Anthony and Walshaw (2009) believes that, daily activities in the classroom play a very important role on how learners grow to understand mathematics. Effective teachers then give students the chance to find solutions to mathematical concepts by providing them with a good atmosphere that encourages them to think on their own. Effective teachers are very crucial when training students to understand mathematical concepts (Cobb and Hodge, 2002 as cited in Anthony and Walshaw, 2009).

For effective teaching of mathematics, there is the need to employ manipulatives, other teaching aids and everyday activities during the first stages of teaching mathematics to help students easily grasp mathematical concepts taught them (Burghes et al, 2012).

Manipulatives according to Heddens (2005, as cited in Durmus and Karakirik, 2006, p.126), are “concrete models that involve mathematical concepts, appealing to several senses including socio-cultural needs that can be touched and moved about by learners.” They are anything that it can be touched and moved about such as base-ten blocks, fraction pieces, pattern blocks and geometric solids that make it easier for learners to comprehend ideas that are not tangible. Kelly (2006, p.184) explains that, “manipulative is a term used to define any tangible object, tool, model or mechanism that can be used to clearly demonstrate the depth of understanding of a problem about a mathematical topics(s)”. Moyer (2001) also makes it known that as learners handle manipulatives they build a repertoire of images that can be used in mental manipulation of abstract concepts.

Manipulatives are classified into two, namely; physical or concrete manipulatives and virtual or digital manipulatives. Suh (2005) defines physical or concrete manipulatives as things that can be touched and put together in a way that would encourage the comprehension of mathematical concepts. Such objects include tangrams, base ten cubes, cuisenaire rods, geoboards and colour tiles. Belenky and Nokes (2009, p.103) mention that concrete manipulatives are “physical objects that are supposed to help the students concretise his or her own knowledge by expressing concepts and performing problem-solving steps with them”.

On the contrary, virtual manipulatives are objects that cannot be touched, and exist only on the television or computer screens, that help to make mathematical ideas easy to understand (Suh, 2005). In addition to that, Moyer, Bolyard and Spikell (2002) as cited in Suh (2005, p.25) explain virtual manipulatives as an “interactive, web-based visual representation of a dynamic object that presents opportunities for constructing mathematical knowledge”. They further add that, for visual objects to be considered as a virtual manipulative, it should have the ability to be turned over, move smoothly and handled like a three-dimensional object. They add that, despite the fact that they may look like real objects, they are more abstract since they cannot be touched.

Frost (2013) outlines some of the importance of manipulatives as:

1. Gives students concrete experiences since they will see mathematical concepts in physical form.
2. Engages different senses of students. These senses include senses of touch, sight and hearing which satisfies different types of learners in the classroom.
3. Helps students to solve problems that are not easy to solve with something to reason with.
4. Makes teaching and learning a fun activity as students learn and play at the same time. Thus, eliminating boredom from the classroom.
5. Shaw (2002) adds that, manipulatives reduce confusion in the teaching of mathematics, makes students not easily to forget what they learn, heighten their mathematics interest, and also lay a good foundation for them to further their studies in mathematics. She further adds that manipulatives improves how students think mathematically and how they even understand one another when they work in groups.

### The SAM Model

Successive Approximation Model (SAM) is an agile development model created by Michael Allen, a recognized pioneer and leader in the design of interactive multimedia learning tools and applications. SAM is a method that Allen applied to his instructional design models as a means of creating more effective and efficient ways to build quality training and instructional tools (eLearning Mind, 2015). With SAM, the goal is to take smaller more flexible steps within a larger framework to achieve high quality in training and learning as opposed to following the rigid, step-by-step process that is attributed to other instructional design methods such as ADDIE (Marshavkiy, 2014).

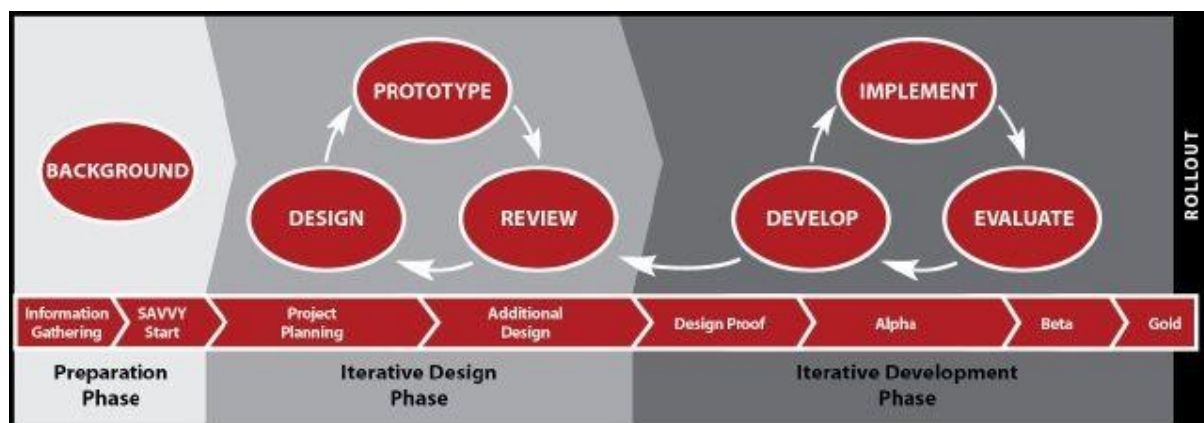

Fig. 1: SAM

Source: Allen (2012)

According to Marshavkiy (2014) SAM is a rapid development model that uses a continuous iterative process throughout the lifecycle of development rather than the “one step at a time in three-quarter time” model. Iteration is “a procedure in which repetition of a sequence of operations yields results successively closer to a desired result” (Allen, 2012). Allen (2012) adds that, without an iterative process, we would have half-baked learning modules more reflective of original intent than polished product.

Throughout the years various instructional design formats have been introduced to assist with the process of creating curricula and course planning options that would prove successful in helping people learn. Although some of these models such as ADDIE have proven the test of time, currently the use of the Successive Approximation Model (SAM) has become quite popular for its unique, flexible approach to producing learning modules that have proven quite successful in application (Allen, 2012).

The flexibility of SAM allows for the development of learning and training materials that account for possible mistakes at each step that is often rectified with collaboration and team work as stated by Allen (2012).

Using SAM for learning and training purposes allows for the creation of materials that take into the consideration their real world application. Nothing is perfect, but flexibility creates results according to Marshavkiy (2014).

### **Advantages of the Successive Approximation Model**

There are a number of reasons why the successive approximation model is highly preferred by those implementing educational models for testing such as through eLearning as well as by instructional designers (Allen interactions Inc., 2015). Some of the advantages include:

- It considers various points of views allowing for the consideration of options that could improve the learning or training experience.
- Uses iterations-small steps during the development process which makes room for evaluations and necessary changes as needed.
- The goal is to find out where energy and resources should be placed immediately in order to create projects/material that can be used at once.
- Very collaborative/teamwork based.

### **Disadvantages of the Successive Approximation Model**

Just as there are many reasons why people prefer SAM over other instructional design models, there are some disadvantages. Allen interactions Inc., (2015) gives some of the disadvantages of SAM as:

- The idea that mistakes are “inevitable” may result in overlooking potential issues in a project
- Doesn't acknowledge and account for risk in relation to the effectiveness of a project in comparison to other instructional design models.
- One must consider a variety of input which can lead to less cohesiveness if not monitored correctly
- There is a need for a considerable amount of collaboration to ensure the cohesiveness of the project

## METHODOLOGY

This study was a qualitative research. The descriptive and quasi-experimental research methodology was employed to describe vividly how the teaching and learning of mathematics was done at the selected lower primary schools (classes 1-3). The study used the convenient sampling technique to select the two schools. The purposive sampling technique enabled the research pick schools that one is believed to be deprived of educational resources (Akrom M/A Primary School) and another believed to be endowed with educational resources (KNUST Primary School) to get a balanced study. The population for the study was made up of all the teachers, pupils and head teachers of the selected lower primary schools. KNUST lower primary had six classes for each primary class (eg. 1a, 1b, 1c, 1d, 1e, 1f) while the lower primary of Akrom M/A Primary School was made up of two classes each (eg. 1a and 1b). Therefore, the total population for the study was 940 out of which KNUST Primary School had 793 (18 teachers, 774 pupils, 1 head teacher) while Akrom M/A Primary School had 147 (6 teachers, 140 pupils, 1 head teacher). The target population was made up of half the number of the total population which was 470. The accessible population of the study was made up of one class at each level of the primary school (1, 2 and 3). 206 was the accessible population for the study with KNUST Primary having an accessible population of 132 (3 teachers, 129 pupils) while Akrom M/A Primary School had an accessible population of 74 (3 teachers, 70 pupils and 1 head teacher).

### Accessible Population for the Study

	Teachers	Pupils	Head teachers	Total
<b>KNUST Primary</b>	3	129	-	132
<b>Akrom M/A Primary</b>	3	70	1	74
<b>Total</b>	6	199	1	<b>206</b>

**Table 1.1:** Accessible Population for the Study

The non-participant observation was employed for data collection with the aid of an observation checklist. Interview was another research instrument that was used in the data collection with an interview guide.

## ANALYSIS AND DISCUSSION OF MAIN FINDINGS

In both schools, the observations were done in primary one on the teaching of addition (sums from 1-9), in primary two on the teaching of subtraction (subtraction of numbers less than 100) and in primary three on subtraction (numbers less than 9999).

Among some of the manipulatives observed at both schools are shown in the plates below.

## Samples of manipulatives used at Akrom M/A Primary School



Plate 1: Cut straws used for counting in Primary One



Plate 2: Cut broom sticks used for counting in Primary One



Plate 3: Bottle tops used for counting in Primary One



Plate 4: Small stones used for counting in Primary One

### *Analysis of Results from Observations Made at Akrom M/A Primary School*

The language of instruction at Akrom M/A Primary School was a blend of English and “Twi” but “Twi” was predominantly employed. Among the manipulatives observed were counters in the form of cut straws made of plastic, cut broom sticks, bottle tops, collected stones and coloured pencils. This suggests that teachers only employed the basic items that could be found in the environment and improvised as manipulatives for teaching additions and subtraction. It can therefore be said that, teachers were eager to use manipulatives if only they were available.

Pupils were tested on the taught concept by calling pupils to the writing board to answer questions posed. Again, exercises were done in class and assignments given to pupils to do in their exercise books for assessment. Even though, some teachers improvised items such as stones, pieces of broom sticks and bottle tops, they did not utilise them well and still taught additions and subtraction on the writing board. Further, it is important to note that materials such as brooms, straw, card board, paper and bottle tops were fragile therefore, could not be sustained for long since they could be easily destroyed. Due to this fact, most of the

calculations were done on the writing board, most of the pupils could not concentrate but instead fidgeted in the classrooms where as others put their heads on the table to sleep.

### Samples of manipulatives used at the KNUST Primary School



Plate 5: A pupil using an abacus to learn in Primary One



Plate 6: Plastic counters for counting from Primary One to Three

### *Analysis of Results from Observations Made at KNUST Primary School*

The language of instruction from Primary One to Three for mathematics was strictly English. The study showed that the manipulatives used for teaching maths in this school were plastic counters and abacus. Only these two manipulatives available were effectively used by teachers and pupils. The abacus was a very common manipulative available to all levels in the lower primary school and was strong enough to last long. Assessment was also done here like it was done at Akrom M/A Primary School by calling pupils to come to the board to answer questions and also do some in their exercise books.

### **Findings from Interviews**

#### *Results of Interviews with the Teachers at the Akrom M/A Primary School*

It was found out with the preferred methods of teaching that teachers combined different instructional strategies such as lecture, discussion, and demonstration strategies in their teaching. They stated that, manipulatives were non-existent so they improvised by asking pupils to bring to class bottle tops, cut out straws, sticks, and pieces of broom sticks to the classroom. They again mentioned that they find it difficult to create manipulatives because they have not been trained either from the teacher education institutions or in their present jobs hence, they find it challenging to teach some topics in mathematics without appropriate manipulatives. They reiterated the challenging topics as multiplication, division, fractions, plane shapes, concept of time, geometric solids, capacity and weight, and length and area.

Out of the three teachers aged between 25 and 30, one had a Bachelor Degree whereas two had Diploma in Basic Education certificates. This means that the teachers teaching mathematics at the lower primary are young and therefore have the energy and enthusiasm to teach. They mentioned that, although it is obvious that they are not as experienced as the teachers with over 20 years of teaching experience, teaching and learning with manipulatives

were exciting, made pupils understand maths concepts easily and as well made them pay very good attention in the classroom.

Notwithstanding their lack of experience compared to their senior colleagues, all of them have experience in the teaching of maths at the lower primary. One of them made it known that she had taught maths at the lower primary level for a little over 5 years.

### ***Results from Interviews with Teachers from the KNUST Primary School***

It was found out that the instructional strategies employed in this school were lecture, discussion, demonstration, brainstorming and role playing depending on the topic for the particular mathematics period. Those manipulatives were for only addition and subtraction. They found it challenging to teach topics such as geometric solids, plane shapes, concept of time, multiplication, division, capacity and weight with the absence of manipulatives.

From the six female teachers interviewed, two had 1st Degree in Basic Education and four possessed Diploma in Basic Education (DBE) certificates. Four of them were between the ages of 25-35 and two between the ages of 45-55. Three of them had between 1-5 years', two had 6-10 years' and one had over 16years' of teaching experience, all at the lower primary school level.

It came out that, when the teachers used manipulatives to teach, it was easy to attract and retain the attention of pupils. That is, pupils showed more interest in the subject, answered questions correctly and every one of them participated in the lesson. A foreign teacher on an exchange programme at KNUST Primary School made it known that manipulatives makes teaching and learning so easy. But without them teaching and learning becomes very frustrating.

Findings from interviews with teachers of both schools revealed that, some topics in mathematics were challenging to teach and learn without manipulatives. Among these topics were, geometric solids, plane shapes, concept of time, multiplication, division, capacity, weight, fractions, length and area. This study was to design and develop manipulatives for five of those topics in mathematics namely, geometric solids, plane shapes, multiplications, concept of time and fractions.

The design and development of the manipulatives were done using the Successive Approximation Model (SAM).

### **The SAM Process**

The SAM process is made up of three phases namely: preparation, iterative design and iterative development.

#### ***Preparation phase:***

Instead of starting with a long, drawn-out evaluation of the existing or “needed” content, SAM starts with the preparation phase—where you gather information and get all the background knowledge. Allen (2012) makes it known that during information gathering, some of the questions that needs to addresses are:

- What have we done before?



- What works best?
- Who is the training for?
- Who will be in charge of this training?

This is intended to be a very quick phase according to Allen (2012). This phase continues with the Savvy Start, which Allen (2012) considers as the key to SAM. As stated by Allen, the savvy start kicks off with a very engaging brainstorming session which is done by meeting face-to-face with all those whose ideas are needed, These people includes the team members, recent learners and managers , and every stakeholder.

Background information was sought considering the teaching of Math from the two selected lower primary schools by interviewing the head teachers and Math teachers.

These schools were made up of two public schools. The interview revealed that there were some challenges with the teaching and learning of Mathematics. Some of the weaknesses include lack of manipulatives for most of the topics in Math which makes it difficult explaining math concepts effectively. There was a non-participatory classroom observation of instructional strategies and activities employed to teach Math in the sampled schools; and the kind of Math manipulatives used in delivering classroom instructions.

Based on the instructional challenges identified in the teaching of Math, the study proceeded to a savvy start. The savvy start consisted of having an engaging brainstorming meeting with the heads of the primary schools, teachers of Maths at the lower and upper primary schools, and representatives of the Parent Teachers Association (PTA) of the schools. All these people came together to brainstorm on the challenges that faced Mathematics at the lower primary school level and came up with suggestions as to how to fix those problems. The brainstorming meetings were done separately in the individual schools. After the brainstorming sessions, the stakeholders deliberated on five topics which they considered as challenging to teach topics at the lower primary schools which needed solutions. These topics were: Multiplication, Fractions, Concept of Time, Geometric shapes and Plane shapes. Afterwards, they deliberated on whether to create concrete objects or create an e-learning platform to improve the teaching and learning of Maths at the lower primary level.

### ***Iterative Design:***

Allen (2012) adds that, the iterative design phase is where the project is planned. At the planning stage, brainstorming again takes place to see how the contents will be put together using different options to decide on the most appropriate design.

At the iterative design phase, the different ideas brought during the savvy start on the instructional challenges to teach topics in Maths were put on paper to produce a design document. Different designs were iterated through design, prototype and review to better define the designs. All these considered project planning which leads to the bringing forth of additional designs. This resulted in the design of an interactive clock to teach time which allows learners to remove components of the clock. Moreover, the clock had a fraction piece that aid teach quarter past times and half past times.

Designs were also made for geometric solids models and plane shapes which were used as templates. In addition, multiplication board with counters was designed to easily facilitate the teaching of multiplication. Lastly, a manipulative for teaching fractions from one whole (1) to one eight ( $1/8$ ) of fraction was designed. All the designed manipulatives were prototyped and reviewed frequently as stipulated by the iterative design phase of the SAM.

### Designs of the Proposed Manipulatives for teaching “Challenging Mathematics Topics”

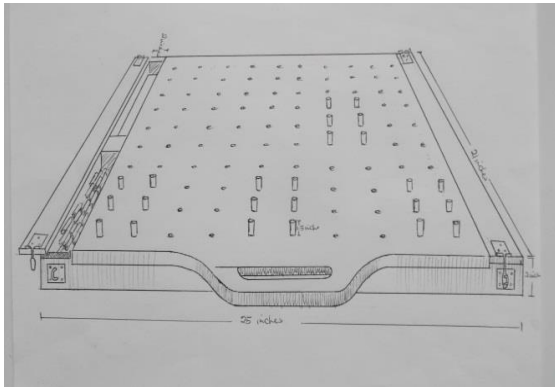

Fig. 2a: Design for multiplication

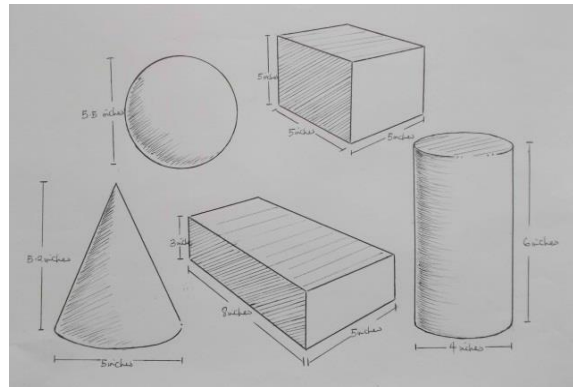

Fig. 2b: The design of geometric solids

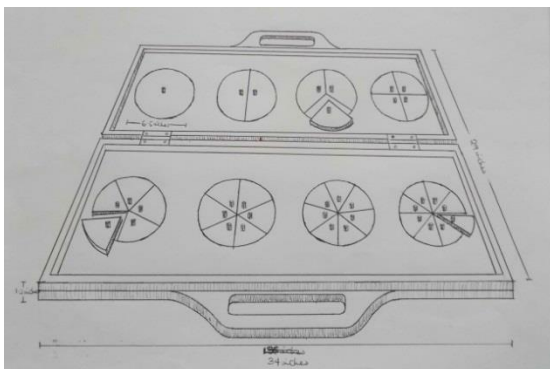

Fig. 2c: Design of manipulative for fractions (opened)

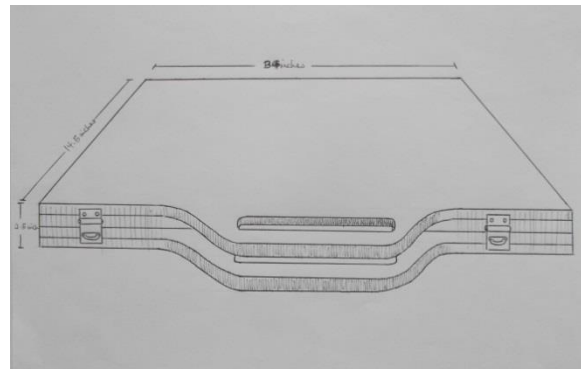

Fig. 2d: The design of manipulative for fractions (closed)

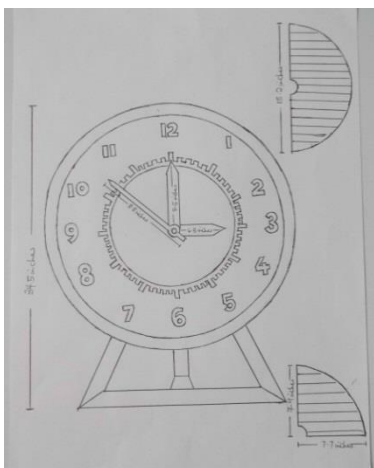

Fig. 2e

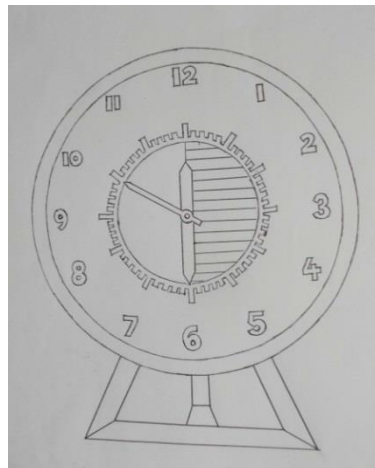

Fig. 2f

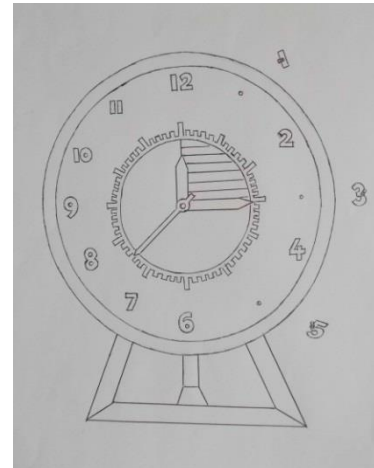

Fig. 2g

- Fig. 2e: The design of a clock to teach time (with a quarter piece and a half piece)  
Fig. 2f: The design of a clock to teach time depicting half past twelve (with the half piece)  
Fig. 2g: The design of a clock depicting quarter past twelve (with the quarter piece)

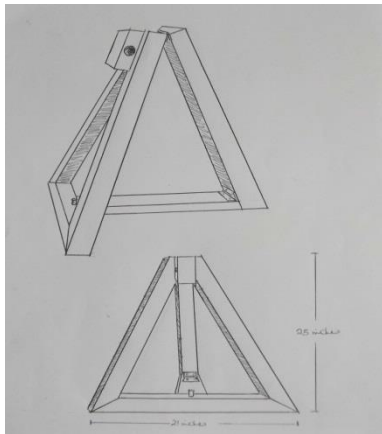

Fig. 2h: The designs of the clock stand (side and front views)

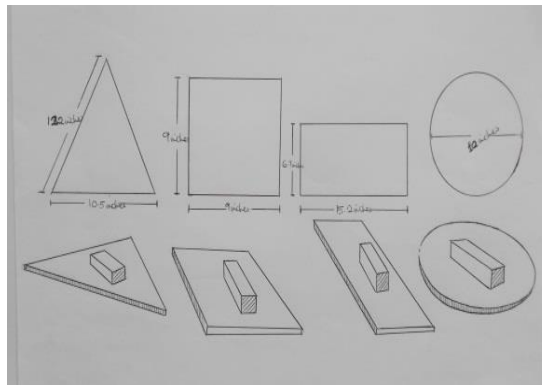

Fig. 2i: The design of shape templates for teachers

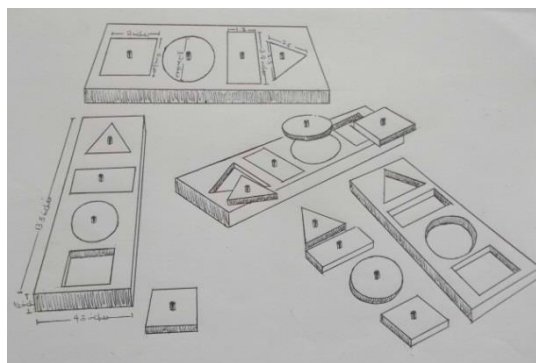

Fig. 2j: The design of shape templates for pupils

### ***Iterative Development:***

The iterative development started with the design proof which is the blueprint for the development phase. In this context, the various designs that were made for the different manipulatives served as the design proof for the iterative development. At the iterative development phase, the process was iterated through development, implementation and evaluation. This means that, when the works were developed, they were implemented in the classroom by testing it with the pupils to see if it was successful and evaluated. This goes on till all corrections are made. The iterative development process is made up of four steps namely, design proof, alpha, beta and gold.

The next step at the iterative development phase was proceeding to the alpha which is where the actual creation of the work started. With the exception of some the geometric solid models like sphere, cylinder and cone which were first modelled in clay and cast using resin and fibre glass, all the other manipulatives were made from wood. So at the alpha stage of iterative development, the geometric solid models such as sphere, cone and cylinder were first

modelled in clay whiles other geometric solid models like cuboid and cube were constructed with wood using the process of nailing. The other manipulatives like the clock manipulative, fraction manipulative, plane shape templates and multiplication manipulative were also made using wood with the process of nailing.



Fig. 3.2: The cut fraction manipulative under cutting and sanding

Fig. 3.1: The assembled clock face after construction



Fig. 3.3: Modelling of a cone in clay

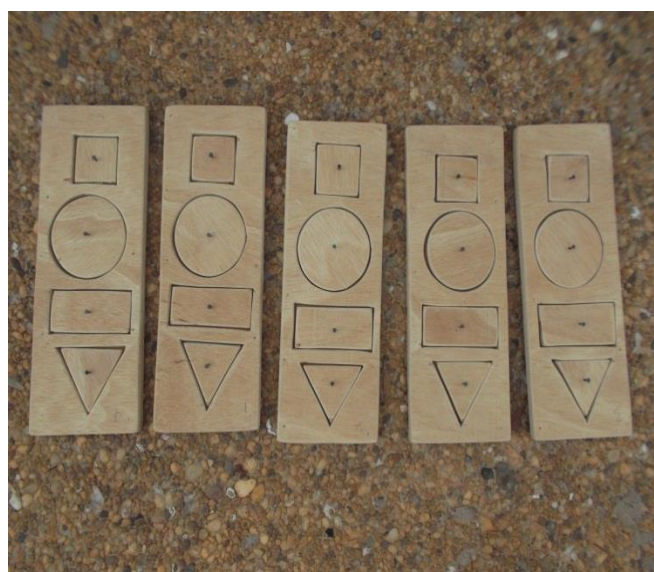

Fig. 3.4: Cut and sanded plane shapes template for pupils



Fig. 3.5: Cut and sanded plane shape templates for teachers



Fig. 3.6: Cut and sanded multiplication manipulative top and counters

The next stage that followed alpha at the iterative development phase is beta. At the beta stage, putty filler was used applied to the all the parts made in wood including the joints after which they were sanded to make the surface of the wood smooth. With the geometric solid models which were modelled in clay, they were cast into resin and sanded after which putty filler was then applied to fill any pore or depression on the surface.



Fig. 4.1: Puttied and sanded multiplication Manipulative



Fig.4.2: Puttied and sanded plane shape templates for teachers



Fig. 4.3: Puttied and sanded plane shape templates for pupils



Fig. 4.4: Puttied and sanded fraction manipulative



Fig. 4.5: Puttied and sanded geometric solids

The last stage of the iterative development phase is the gold stage. At this stage all the finishing touches of the various manipulatives were given and the works sprayed in attractive colours. Afterwards, a coat of clear mixed hardener was sprayed on the paint to protect the paint and also to make it more pleasing to the eye.



Fig. 5.1a: The complete clock with all the numbers fixed



Fig. 5.1b: Clock with some numbers taken off



Fig. 5.1c: The clock with a fraction piece depicting quarter past nine



Fig. 5.1d: The clock with a fraction piece depicting half past ten

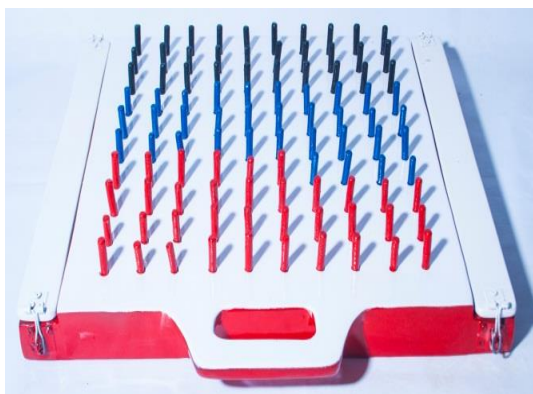

Fig. 5.2a: A multiplication board with all 100 canes in drilled holes

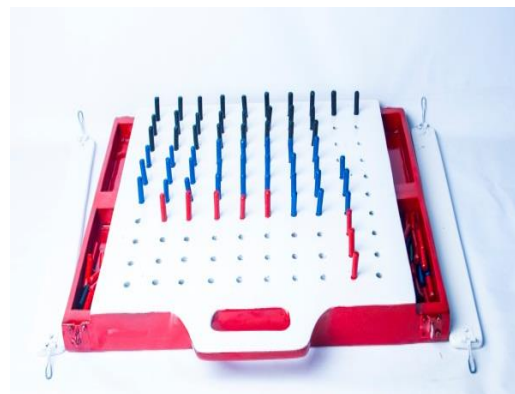

Fig. 5.2b: The complete multiplication manipulative without some of the counters



Fig. 5.3a: First fraction manipulative



Fig. 5.3b: Second fraction manipulative



Fig. 5.4a: Complete shape templates for pupils

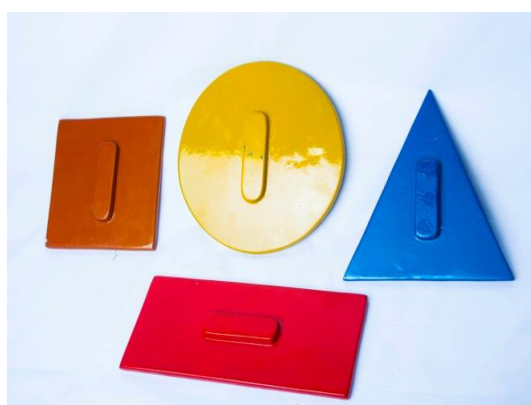

Fig. 4b: Complete shape templates for teachers



Fig. 5: The finished geometric solids in bright colours

The work was then rolled out. This was done by first giving the various teachers of mathematics in both schools training on how to use the developed manipulatives in the classroom to teach the challenging topics in mathematics.



First and foremost, the teachers were asked to employ the existing instructional strategies for teaching Mathematics with available teaching and learning resources before the introduction of interventionary Math manipulatives; and tests were organized and recorded.

The teaching of time as a lesson was done by drawing the clock on the writing board after with no other activity to better explain the concept. The teaching of fractions was also done on the writing board with no other activity to explain. The same approach was used to teach plane shapes and geometric solids as well as multiplication.

The teachers taught the same mathematics concepts again using the developed manipulatives to better explain the concepts with more practical activities. Tests were again organized and results recorded.

Table 1 shows the test results of the using the existing methods of teaching mathematics as well as the that of the developed manipulatives.

**Table 1: Test Results Recorded to Compare KNUST and Akrom Primary School Pupils' Understanding of Some Maths Concepts**

Mathematics lessons	KNUST Primary School		Akrom M/A Prim. School		Total (100%)
	Test scores of existing TLMs	Test scores of Maths Manipulatives	Test scores of existing TLMs	Test scores of Maths Manipulatives	
Time	8 (80%)	10 (100%)	4 (40%)	8 (80%)	10 (100%)
Multiplication	6 (60%)	8 (80%)	4 (40%)	7 (70%)	10 (100%)
Fractions	5 (50%)	10 (100%)	5 (50%)	9 (90%)	10 (100%)
Geometric solids	2 (40%)	5 (100%)	2 (40%)	4 (80%)	5 (100%)

Comparison of Test Results from the Two Schools are Interpreted in Bar-Charts

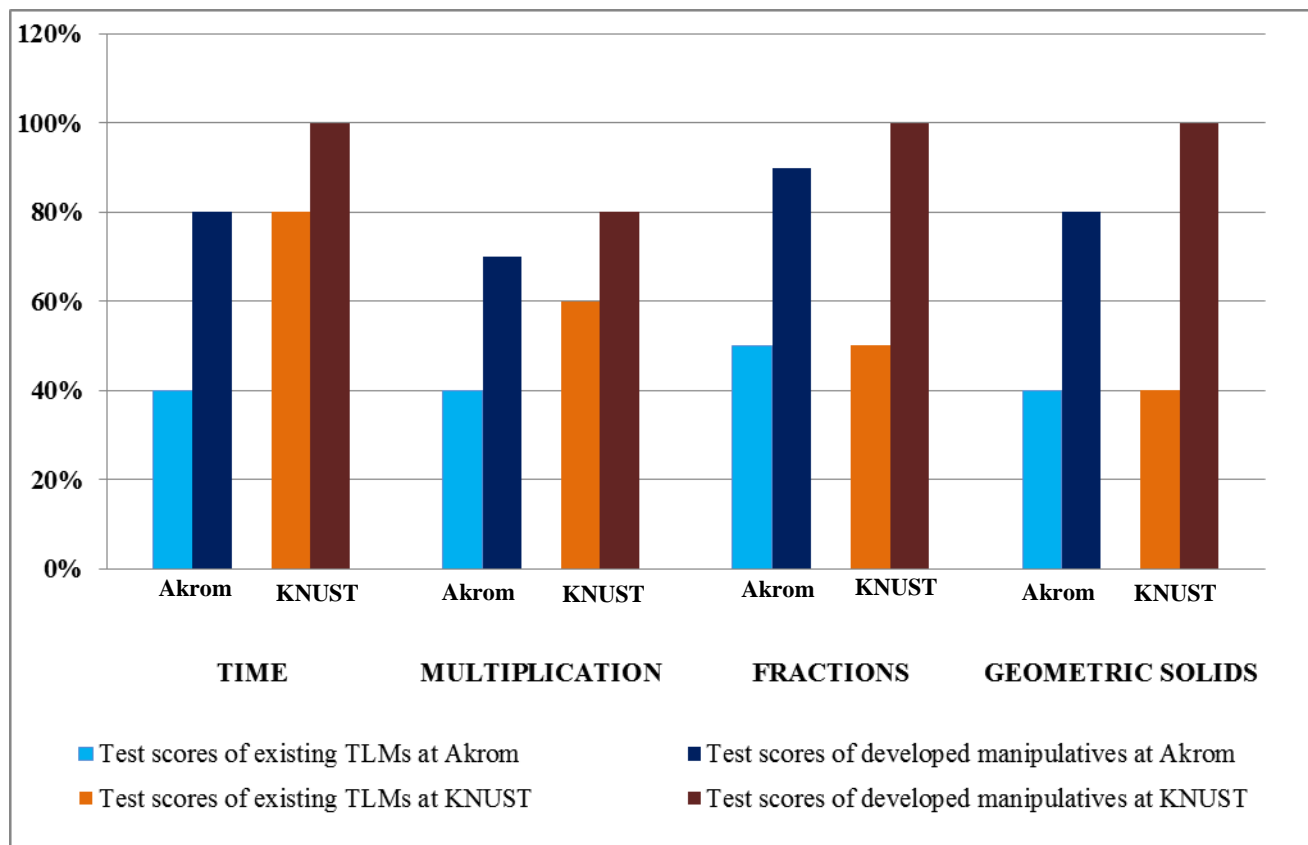

**Fig.19: Comparison of Test Results from Akrom M/A and KNUST Primary Schools**

Summative assessment were conducted on the two sampled schools before and after the introduction of the intervention of math manipulatives. The results evident that:

On the issue of test scores with the teaching of time, pupils of KNUST attained 80% with the traditional methods but performed excellently (100%) with the proposed manipulative. On the other hand, Akrom M/A performed below average that is 40% without the developed manipulative but attained 80% achievement rate with the use of the manipulative. These may be due to the fact that pupils from Akrom were taught using the back setting to determine a specific time.

With regards to assessment on the manipulative to teach multiplication, pupils at Akrom M/A Primary School had 40% correct from teaching with the existing methods but achieved 70% with the use of the manipulatives. At KNUST Primary School, pupils recorded an average performance of 50% with the existing TLMs but increased to 90% with the proposed manipulatives. This confirms what Wallace and Gurganus (2005) say that lessons for multiplication should be full of different hands-on objects for pupils to manipulate since that helps them to better understand multiplication concepts taught them.

It was clear from the assessment of the manipulative to teach fractions that, out of ten pupils from each school that participated in the class exercises, both scored 50% with their existing ways of teaching and KNUST recorded 100% and Akrom M/A had 90% when taught with manipulatives. This shows that, KNUST recorded 100% improvement rate whereas Akrom had 90% increment in understanding of fractions. Francis (2006) postulates that

fraction operations consist of addition, subtraction, multiplication, division, comparing and simplifying, hence, they are difficult for learners to grasp and understand these rules at a goal.

Records from both schools on the teaching of geometric solids indicated that 40% of pupils had answers correct when teaching with their traditional methods which signified a below average performance. Conversely, 100% scores were recorded in the two schools when they were taught with the proposed manipulatives. This signifies that there is a high increase in academic performance achieved as far as understanding geometric solids is concerned.

Manipulatives for plane shapes were tested with Primary One pupils in both schools. KNUST teacher taught the various shapes from cut out shapes from card board and due to the small size of the shapes, they were not visible when the teacher showed them. At Akrom M/A, teaching was done by drawing them on the writing board. It took quite some time for the teacher to draw all the plane shapes on the board before instruction began. Afterwards, pupils were asked to draw them in their books and it took a very long time for them to draw, meanwhile, some could not draw.

However, the manipulatives for plane shapes made it very easy and convenient for the teachers to draw on the board. In both schools, since they were big in size, pupils sitting at the back of the class could see clearly. The plane shapes templates for pupils enabled pupils of both schools to draw with ease and also gave them the opportunity to touch and feel.

## CONCLUSIONS

- Although the research was done in only two primary schools in the Kumasi metropolis, analysis of the major issues affecting mathematics education among pupils indicated that, there were temporary and very delicate items like bottle tops, pieces of broom sticks, cut straws, abacus and pebbles that served as manipulatives for counting (additions), the rest of the topics lacked the adoption of suitable manipulatives during teaching sessions. This resulted in pupils' difficulty in understanding simple mathematical concepts. The study also showed that, the common TLMs employed for teaching all topics in mathematics at the lower primary level of education were textbooks and writing boards.
- The teaching of topics in mathematics without manipulatives made pupils to fidget a lot in the classrooms. As a result, they did not pay attention during the teaching of mathematics. Meanwhile, the use of the few manipulatives in the classroom ignited pupils' interest in mathematics and made them participate fully in class. Frost's (2013) confirms this by stating that manipulatives assist learners to solve mathematics tasks confidently since they interact with them to see abstract concepts in a physical form and also satisfy academic needs of the different types of learners in the classroom. Teaching with the proposed manipulatives were fun and exciting compared to the traditional methods employed for teaching mathematics to the same group of pupils.
- Using carefully prepared manipulatives to guide instruction in the classroom will promote more effective teaching to help pupils acquire knowledge and skills in

mathematics to serve as preparatory grounds for further studies since every pupil is required to pass the compulsory mathematics subject.

- Last but not the least, from the results, that pupils' academic performance recorded showed that choosing the appropriate manipulatives for mathematics education, especially, at the lower primary school impacted positively on pupils understanding of "challenging to teach and learn topics" which led to achieving greater academic success in both schools.

## RECOMMENDATIONS

The following recommendations can help to improve pupils' performance in mathematics.

- In developing country like Ghana, the GES should give priority to manipulatives and TLMs beyond text books, teacher guides and writing boards, therefore, manipulatives should be available for every pupil to be used in all topics in mathematics to guide instructions of mathematics concepts.
- To get the most of appropriate manipulatives in mathematics education, teachers should have mastery of the subject(s) they teach so as to enable them use manipulatives to suit the content for each topic. When this is achieved, pupils will easily relate what is learned to everyday activities to benefit families, communities, the country and the world at large.
- Primary school mathematics teachers should be taught on how to develop simple manipulatives at the Colleges of Education and during workshops and in-service training sessions by Ghana Education Service (GES) or Non-Governmental Organizations (NGOs) to assist in resourcing them to teach mathematics effectively at the primary schools.
- Art teachers can be consulted by mathematics teachers to orient them on how to use art to create simple classroom activities to teach mathematical concepts to enhance the teaching and learning of mathematics among pupils. Teachers should then be supervised by Ghana Education Service to ensure that the basics of mathematics education in the primary schools are realized.
- Ghana Education Service (GES) and Curriculum Research and Development Division (CRDD) should revise the syllabus to give more time to practical subjects like mathematics. This will offer teachers ample time to employ effectively and efficiently strategies to teach mathematics to pupils in the primary schools.

## REFERENCES

- Allen, M. (2012). *Leaving ADDIE for SAM: An Agile Model for Developing the Best Learning Experiences*. Alexandria, VA: ASTD Press. ISBN: 978-1-56286-711-9. 208 pages.

- Allen Interactions Inc. (2015). Iterative e-Learning Development with SAM. Agile e-Learning Process. Retrieved September 28, 2015 from, <http://www.alleninteractions.com/sam-process>
- Anthony, G. & Walshaw, M. (2009). Characteristics of Effective Teaching of Mathematics: A view from the West. *Journal of Mathematics Education*, vol.2, no.2, p.147-167
- Belenky, D. M. & Nokes, T. J. (2009). Examining the Role of Manipulatives and Metacognition on Engagement, Learning and Transfer. *The Journal of Problem Solving*, vol. 2, no. 2, pp. 102-129.
- Bell, E. T. (2014). *Calling Time on a Traditional Clock? One in Seven Britons Can Only Tell Using a Digital Watch*. Retrieved June 23, 2014 from [www.dailymail.co.uk/scienceteach/article](http://www.dailymail.co.uk/scienceteach/article)
- Burghes, D., Szalontai, T., Koyama, M., Myllyntausta, S., Beston, Y., Hazel, M., Robinson, D., Pitman, P., Smith, R., Kellet, S., & Hunter, J. (2012). *Enhancing Primary Mathematics Teaching and Learning*, p. 1-42. CfBT Education Trust. Retrieved October 26, 2013 from <http://www.cimt.plymouth.ac.uk/papers/epmtl.pdf>
- Durmus, S. & Karakirik, E. (2006). Virtual Manipulatives In Mathematics Education: A theoretical Framework. *The Turkish Online Journal of Educational Technology*, vol. 5, issue 1, article 12, pp.117- 123. Retrieved September 25, 2013, from <http://www.tojet.net/articsles/v5i1/5112.pdf>
- eLearning Mind. (2015). Iterative Design Models. ADDIE vs SAM. Retrieved September, 13, 2015, from <http://elearningmind.com/iterative-design-different-strokes-different-folks>
- Essel, B. A. (2012). *Information and Communication Technology in Art Education*, pp. 41-49.
- Francis, E. (2006). *Why Are Fractions So Difficult to Learn?* Retrieved June 23, 2014, from [www.homeschoolmath.net/teaching.fractions.php](http://www.homeschoolmath.net/teaching.fractions.php)
- Frost, S. (2013). *Importance of Hands-on Manipulatives in Math*. Demand Media. Retrieved from <http://everydaylife.globalpost.com/importance-handson-manipulatives-math-13601.html>
- Frost, S. (2013). *Importance of Hands-on Manipulatives in Math*. Demand Media. Retrieved from <http://everydaylife.globalpost.com/importance-handson-manipulatives-math-13601.html>
- Hom, E. J. (2013). *What is Mathematics?* Retrieved October 9, 2013, from <http://www.livescience.com/38936-mathematics.html>
- Kelly, C. A. (2006). Using Manipulatives in Mathematical Problem Solving: A Performance Based Analysis. *The Montana Mathematics Enthusiast*, vol.3, no. 2, pp.184-193, ISSN 1551-3440.
- Marshavkiy. (2014). The New Frontier of Successive Approximation Model. Your eLearning World. Retrieved September 19, 2015, from [yourelearningworld.com](http://yourelearningworld.com)

- Martinez, J. G. R. & Martinez, N. C. (2010). *The Importance of Mathematical Thinking*. Retrieved October 10, 2013, from <http://www.education.com/reference/article/importance-mathematical-thinking/>
- Moyer, P. S. (2001). Are We Having Fun Yet? How Teachers Use Manipulatives To Teach Maths. *Educational Studies in Mathematics*, v.47, pp.175-197.
- Nikky. (2010). *Teaching Aids, Their Needs, Types and Importance of Teaching Aids in Teaching and Learning Process*, pp.1-2. Retrieved April 17, 2013, from [www.indiastudychannel.com/resources/120148-Teaching-Aids-Their-Needs-Types-Importance.aspx](http://www.indiastudychannel.com/resources/120148-Teaching-Aids-Their-Needs-Types-Importance.aspx)
- Suh, J. M. (2005). *The Grader's Mathematical Achievement and Representation Preference: Using Virtual and Physical Manipulatives for Adding Fractions and Balancing Equations*. Fairfax, Virginia: George Mason University. , pp. 12-38. Retrieved on October 1, 2013, from <http://mason.gmu.edu/~isuh4/dissertation%20final.pdf>
- Wallace, A. H. & Gurganus, S. P. (2005). *Teaching for Mastery of Multiplication*. pp. 26-33.