

Evaluating the mechanical properties of Epoxy resin with Fly ash and Silica fume as fillers

¹Nehad A. Saleh, ²M. H. Al-Maamori ³Mohamed B. Al-jebory, ,
^{1,3}University of Babylon – college of science - Physics Dept. , P.O.BOX4 Iraq
²University of Babylon – college of Materials Engineering, P.O.BOX4 Iraq
E-Mail: facemoo862@yahoo.com

Abstract

Composite material consists of merging two composite materials or more are different in mechanical and physical properties, in this study a composite polymeric material has been prepared, it's mainly used in treatment of cracks that happened in concrete slabs, by using Epoxy resin as a major substance in work while the filler were the Fly ash and Silica fume. Samples were prepared by hand-made molds has special dimensions according to the American Standards for Testing and Materials (ASTM) and adding each filler separately with different ratios as (10%, 20%, 30 %, 40% and 50%), then studying the mechanical properties of these material like tensile, hardness, compression, impact and bending properties.

Key Words : Epoxy resin, Fly ash, Silica fume, fillers.

1. Introduction

Ash residues are wastes of coal fired plants and they are produced at the boiler outlets of plants, these including fly ashes and bottom ashes [1]. The demand for the lightweight materials such as for surfaces of ships had led to the development of fly–ash based thermosetting resins [2-6]. In fiber epoxy composites the addition of fly ash led to a reduction of the density and increase in modulus of composites [4]. At present, epoxy resins are widely used in various engineering and structural applications such as electrical industries, and commercial and military aircrafts industries. In order to improve their processing and product performances, and to reduce cost, various fillers are introduced into the resins during processing [7].

2. Matrix materials

2.1 Epoxy resin

Epoxy resins are the most commonly used thermoset plastic in polymer matrix composites. Epoxy resins are a family of thermoset plastic materials which do not give off reaction products when they cure and so have low cure shrinkage. They also have good adhesion to other materials, good chemical and environmental resistance, good chemical properties and good insulating properties. The epoxy resins are generally manufactured by reacting epichlorohydrin with bisphenol. Different resins are formed by varying proportions of the two: as the proportion of epichlorohydrin is reduced the molecular weight of the resin is increased. Epoxy resins are cured by means of a curing agent, often referred as catalysts, hardeners or activators. Often amines are used as curing agents. In amine curing agents, each hydrogen on an amine nitrogen is reactive and can open one epoxide ring to form a covalent bond.

2.2 Fly ash

Fly ash is a coal combustion byproduct, which accumulates due to electrostatic precipitation of the flue gases in thermal power plant. When coal is burnt in thermal power plant the ash is carried forward in flue gases as fused particles, which solidifies as a spherical particle. Most of these spherical particles have a gas bubble at the center. Fly ash depending upon the source of coal, contain different proportions of silica, alumina, oxides of iron, calcium, magnesium etc. along with elements like carbon, Ti, Mg, etc. So the fly ash has properties combined of spherical particles and that of metals and metal oxides. Table (1) shows the results of chemical analysis of the fly ash using a technique (XRD).

2.3 Silica fume

Silica fume (SF) is a byproduct of the smelting process in the silicon and ferrosilicon industry. The reduction of high-purity quartz to silicon at temperatures up to 2,000 °C produces SiO₂ vapors, which oxidizes and condense in the low temperature zone to tiny particles consisting of non-crystalline silica. By-products of the production of silicon metal and the ferrosilicon alloys having silicon contents of 75% or more contain 85–95% non-crystalline silica. The American concrete institute (ACI) defines silica fume as a "very fine no crystalline silica produced in electric arc furnaces as a byproduct of production of elemental silicon or alloys containing silicon". It is usually a

grey colored powder, somewhat similar to Portland cement or some fly ashes. It can exhibit both pozzolanic and cementitious properties. Table (2) shows the typical characteristics of silica that used in research.

3. Experimentation

Commercially available (Nito fill EPLV) along with hardener was used as matrix material in fabrication of different moulds. For processing the mix ratio (by weight) of epoxy (3 parts) and hardener (1part) are used as specified.

3.1 Raw Material Used

Matrix materials:- Epoxy resin and hardener (Nito fill EPLV).

Reinforcement materials:- Fly ash and Silica fume are used separately with percent of (10%, 20%, 30%, 40%, 50%) by weight of epoxy.

3.2 Preparation of Moulds

Hand-made wooden molds has been used with measurements and dimensions according to the American Society for testing and Materials (ASTM). Table (3) shows the dimensions of the samples and forms.

3.3 Dough preparation

The required mixture of resin & hardener were made by mixing them in (3:1) parts in a beaker by stirring the mixture in a beaker by a rod taking into care that no air should be entrapped inside the solution.

3.4 Casting of slabs

The dough prepared was transferred to moulds cavities by care, the moulds cavities should be thoroughly filled. Leveling was done to uniformly fill the cavities.

4. Mechanical properties

Compression, impact, hardness, tensile and bending tests were carried out using special devices.

5. Results and Discussion

Fabricated materials of different compositions of epoxy resin system have been tested under dynamic loading conditions.

5.1 Compression Strength

The increase of additives ratios of silica fume and fly ash due to increase the compression strength, as shown in Fig (1). The hollowness of fly ash particles increases the material capacity to increase the material capacity to increase energy [8].

5.2 Bending Strength

The increase of additives ratio of silica fume causes decreasing in bending strength, but the fly ash causes ununiformed behavior in bending strength, Fig (2) shows the effect of silica fume and fly ash on bending strength.

5.3 Tensile Strength

The increase of additives ratios of silica fume and fly ash due to increase the tensile strength, as shown in Fig (3).

5.4 Impact Strength

The increasing of additives ratios of silica fume due to increase the impact test, per contra the fly ash causes decreasing in impact strength, as shown in Fig (4). Slight decrease in energy has been observed due to decreased availability of epoxy material to bond all the fly ash particles in the matrix.

5.5 Hardness Strength

The increasing of additives ratios of fly ash due to increase the hardness test, per contra the silica fume causes decreasing in hardness strength, as shown in Fig (5).

6. Conclusion

- The increase of additives ratios of silica fume and fly ash due to increase the compression strength.
- The increase of additives ratio of silica fume causes decreasing in bending strength.
- The increase of additives ratios of silica fume and fly ash due to increase the tensile strength.

- The increasing of additives ratios of silica fume due to increase the impact test, per contra the fly ash causes decreasing in impact strength.
- The increasing of additives ratios of fly ash due to increase the hardness test, per contra the silica fume causes decreasing in hardness strength.

References

1. National Report on Thailand Outstanding Technologist Award By Foundation of the Promotion of Science and Technology under the Patronage of H.M. the King, BKK, Thailand, October, 2002.
2. Chand N. SEM observations of fractured fly-polyester composites. J Mat Sci Lett 1988;7: 36–8.
3. Kishore, Kulkarni SM, Sharathchandra S, Sunil D. On the use of an instrumented set-up to characterize the impact behavior of an epoxy system containing varying fly ash content. Polym Test 2002;21: 763–71.
4. Kulkarni SM, Kishore. Effect of filler–fiber interactions on compressive strength of fly ash and short-fiber epoxy composites. J Appl Polym Sci 2003;87:836–41.
5. Garde K, McGill WJ, Woolard CD. Surface modification of fly ash – characterization and evaluation as reinforcing filler in polyisoprene. Plast Rubb Compos 1999; 28:1–10.
6. Sombatsompop N, Thongsang S, Markpin T, Wimolmala E. Fly Ash Particles and Precipitated Silica as Fillers in Rubbers. I. Untreated Fillers in Natural Rubber and Styrene–Butadiene Rubber Compounds. J Appli Polym Sci 2004; 93:2119–30.
7. Huang Z.M. Tensile strength of fibrous composites at elevated temperature , Materials Science and technology, January 2000, vol 16. 81-93.
8. Gupta NB. Effect of filler addition on the compressive and impact properties of glass fiber reinforced epoxy. Bull Mat Sci 2001;24: 219–23.

Table (1): results of chemical analysis of the fly ash

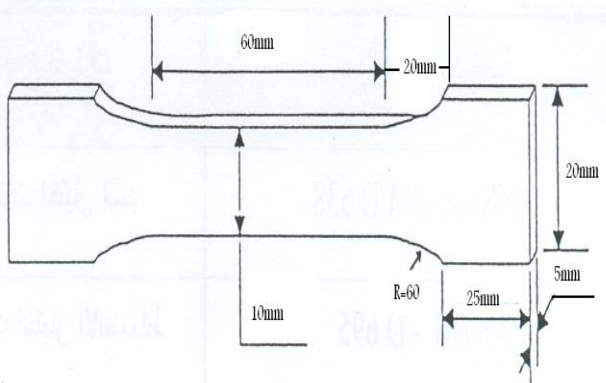
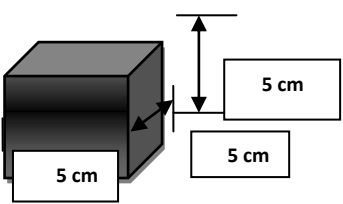
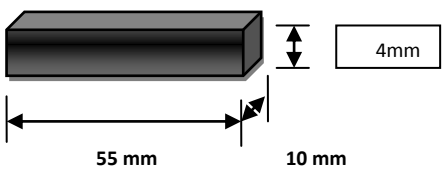
1- Calcite	CaCO ₃
2- Anhydrite	CaSO ₄
3- Halite	NaCl
4- Dolomite	CaMg(CO ₃) ₂
5- Quartz	SiO ₂

Table (2): the typical characteristics of silica fume

1- Form	Undensified powder
2- Colour	Gray

3- Bulk density	150-300 Kg/m ³
4- SiO ₂ content	>85%
5- PH value	Neutral
6- Thermal stability	-10 C ⁰ to +50 C ⁰
7- Physiological effect	Neutral

Table (3): shows the dimensions of the samples and forms.

	Standard	Samples and dimensions	Test
1	ASTM D638-87		Tension
2	ASTM C579 – 01 Method B		Compression
3	ASTM D256-87		Impact

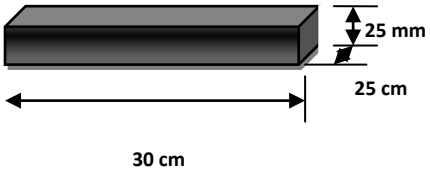
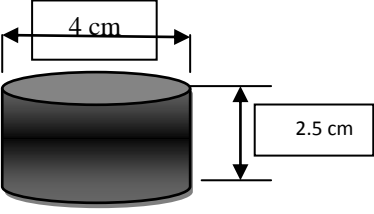
4	ASTM C580- 02		Bending
5	Brinell		Hardness

Fig (1): Effect of silica fume and fly ash on compression strength

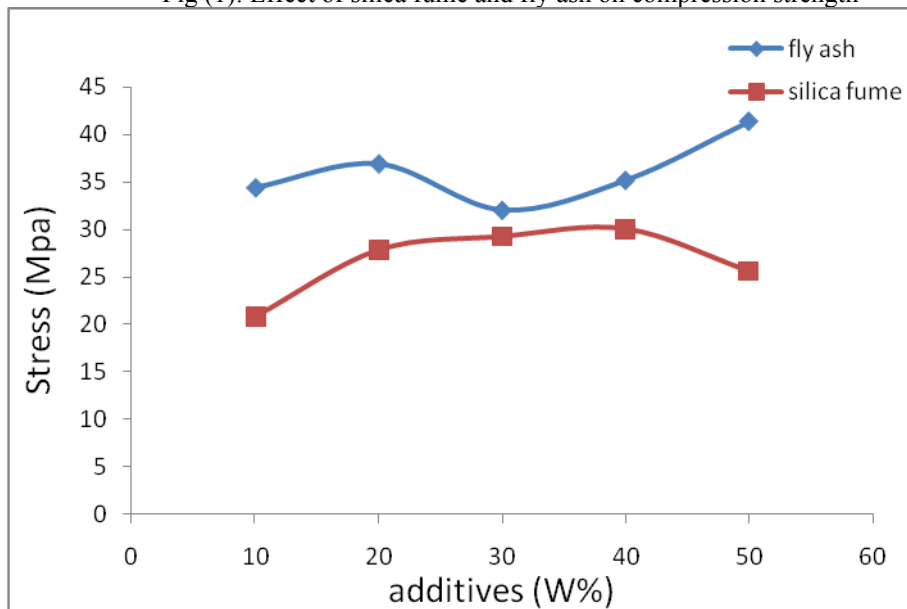


Fig (2): Effect of silica fume and fly ash on bending strength

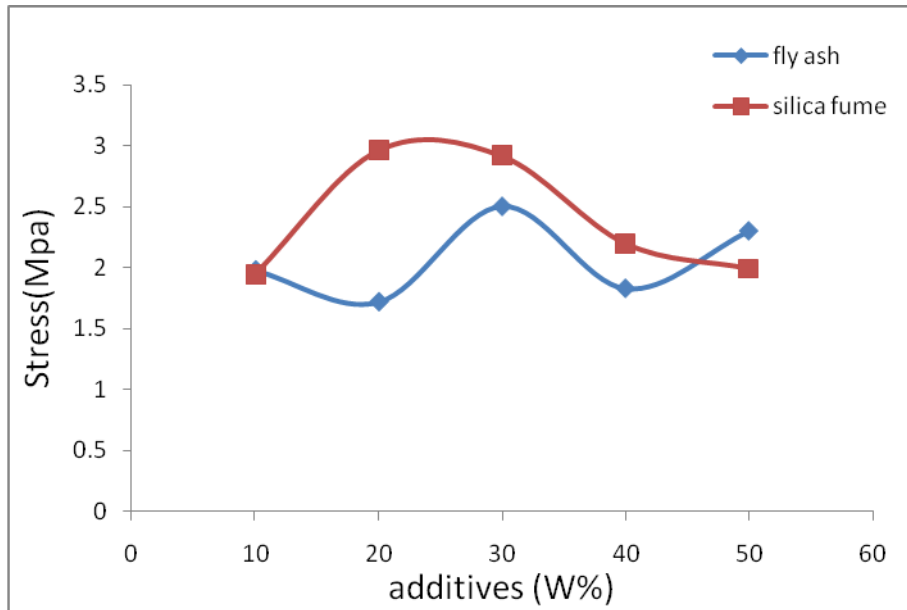


Fig (3): Effect of silica fume and fly ash on tensile strength

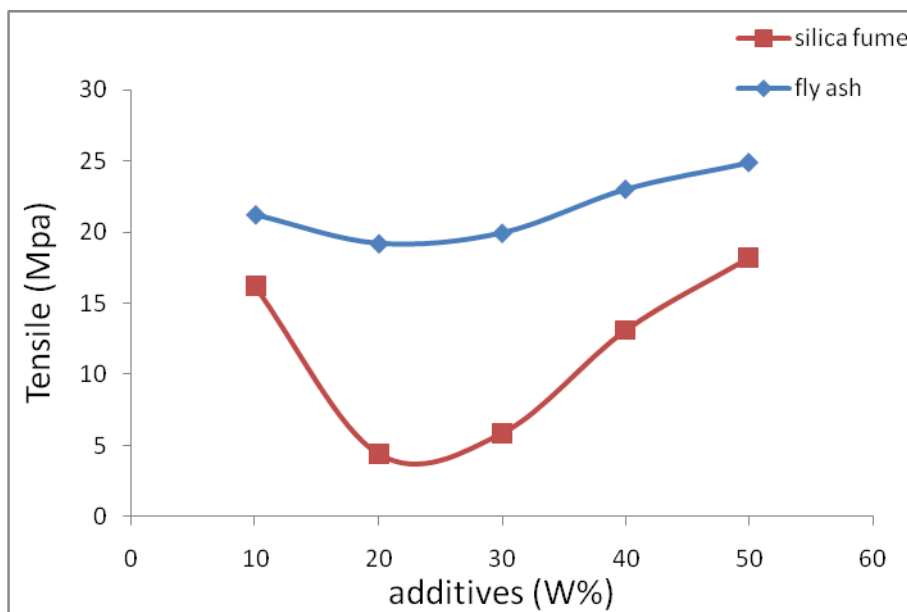


Fig (4): Effect of silica fume and fly ash on impact strength

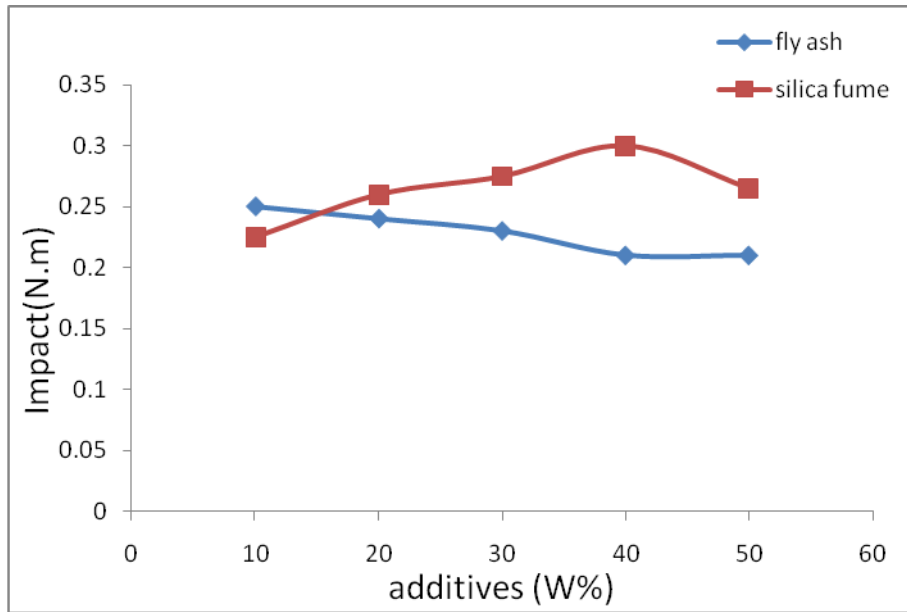
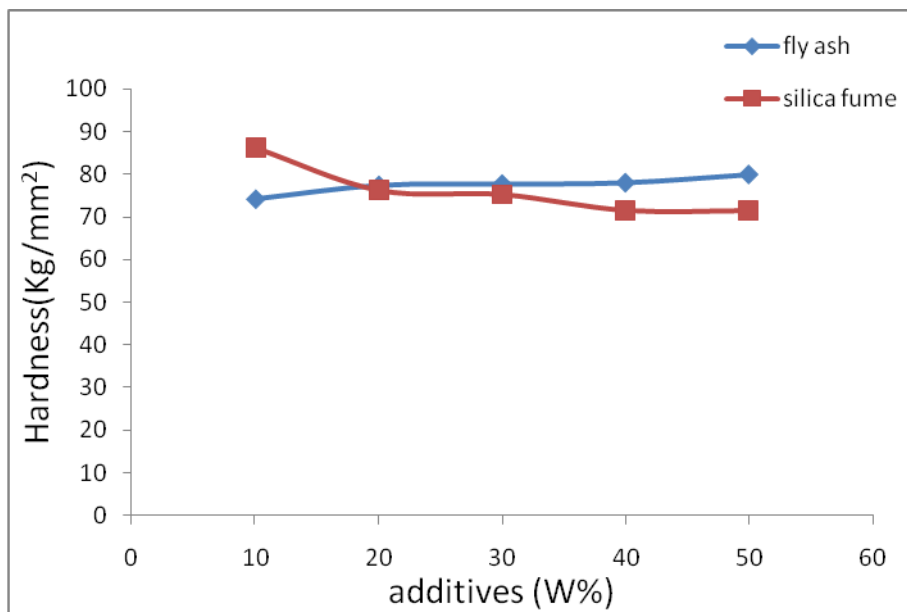


Fig (5): Effect of silica fume and fly ash on hardness strength



The IISTE is a pioneer in the Open-Access hosting service and academic event management. The aim of the firm is Accelerating Global Knowledge Sharing.

More information about the firm can be found on the homepage:
<http://www.iiste.org>

CALL FOR JOURNAL PAPERS

There are more than 30 peer-reviewed academic journals hosted under the hosting platform.

Prospective authors of journals can find the submission instruction on the following page: <http://www.iiste.org/journals/> All the journals articles are available online to the readers all over the world without financial, legal, or technical barriers other than those inseparable from gaining access to the internet itself. Paper version of the journals is also available upon request of readers and authors.

MORE RESOURCES

Book publication information: <http://www.iiste.org/book/>

Recent conferences: <http://www.iiste.org/conference/>

IISTE Knowledge Sharing Partners

EBSCO, Index Copernicus, Ulrich's Periodicals Directory, JournalTOCS, PKP Open Archives Harvester, Bielefeld Academic Search Engine, Elektronische Zeitschriftenbibliothek EZB, Open J-Gate, OCLC WorldCat, Universe Digital Library, NewJour, Google Scholar

