

The Study of Electrohydrodynamic and Wind Ions Direction Produced by Positive Corona Plasma Discharge

M. Nur¹, A. H. Azzulka¹, M. Restiwijaya¹, Z. Muchlisin¹, and Sumariyah²

1. Atomic and Nuclear Laboratory, Physics Department Faculty of Sciences and Mathematics, Diponegoro University, Semarang, Indonesia
2. Electronics and Instrumentation Laboratory, Physics Department Faculty of Sciences and Mathematics, Diponegoro University, Semarang, Indonesia

* E-mail of the corresponding author: m.nur@undip.ac.id

Abstract

The Electrohydrodynamic (EHD) produced by positive corona plasma discharge has been studied. This research used type of electrodes configuration wire to plane electrodes geometry system. Wire electrode that was used is made from stainless steel with 5 cm in length and diameter variation from 0.11 mm to 0.38 mm. The plane electrode that was used has circumference shape with diameter of 20 cm. The data acquisition carried out with variations of voltage, distance between electrodes and the variation of wire electrode diameter. EHD phenomenon analysis was studied by current measurement, minor pivot of deformation changes and the reunification time of lubricant oil after switch of external power or electric field. The characteristics of I-V was formed parabolic ($I_s \approx V^2$). The results also showed an inverse relation between current and geometry factor. We found that the value of characteristic angle of ionic wind flow direction was depending on field electric value and geometry factor. The deformation of lubricant surface returned to its initial condition after cut off the electric field with time returnee depended on the minor pivot deformation.

Keywords: electrohydrodynamic, ion wind, positive corona discharges

1. Introduction

The existence of corona winds has been known for a long time. As indicated by Robinson (Robinson, 1961). Hauksbee reported that he had experienced a weak blowing sensation on holding a charged tube to his face. Since then, the corona wind has become a favorite study subject of many scientists including Newton, Faraday and many more (Robinson, 1961). Chattock in 1899 was the first who proposed a quantitative explanation of the corona wind phenomenon (Chattock, 1899). Electrohydrodynamics in a wire to horizontal plate geometry for gas discharge system have been widely investigated for example (Bondar and Bastein, 1986). The basic mechanisms responsible for the electrohydrodynamic (EHD) force exerted by the discharge on the gas molecules has been discussed and described the plasma dynamics by using two-dimensional fluid model of the DBD by Beouf et. el. (Beouf, 2005). Owsenek and Seyed-Yagoobi in 1997 used a wire to horizontal plate geometry, and studied the effect of the corona wind on the enhancement of the free-convection, heat transfer coefficient. The effect of corona wind produced by stretched steel wire and two copper wings on the heat transfer from a heated horizontal plate was investigated experimentally (Owsenek and Seyed-Yagoobi in 1997). Ionic wind and resuspension of particles under an unequal electrostatic field using a needle electrode and grounded plate have been investigated experimentally. The ionic current from the needle to the target increases with almost the square of the electrostatic field between the needle and particle layer (Tanoue et al, 2006). June et. al., reported devices of ionic wind and it has been done comparison with fans and blowers for industrial application (June, 2011). Effect of ions in the plasma corona wind generated by electrodes on the field of multi - point heat transfer technology that enables such as drying technology has been done for example by (Kim, 2010). The purpose of the present work is to study the of ionics wind by using a single stretched thin wire electrode to

horizontal plate. This study has been done to know direction of wind ions and electrohydrodynamic phenomenon in the lubricant oil.

2. Experimental Technique

Figure 1 shows experimental setup of this work. The corona discharge was generated by wire-plane geometry and variation of gap between wire to plane varied from 4 mm to 8 mm. The wire electrode diameter was varied such as: 0.11 mm, 0.14 mm, 0.21 mm, 0.36 mm, and 0.38 mm. The plane electrode was with thickness 1 cm and diameter of 20 cm.

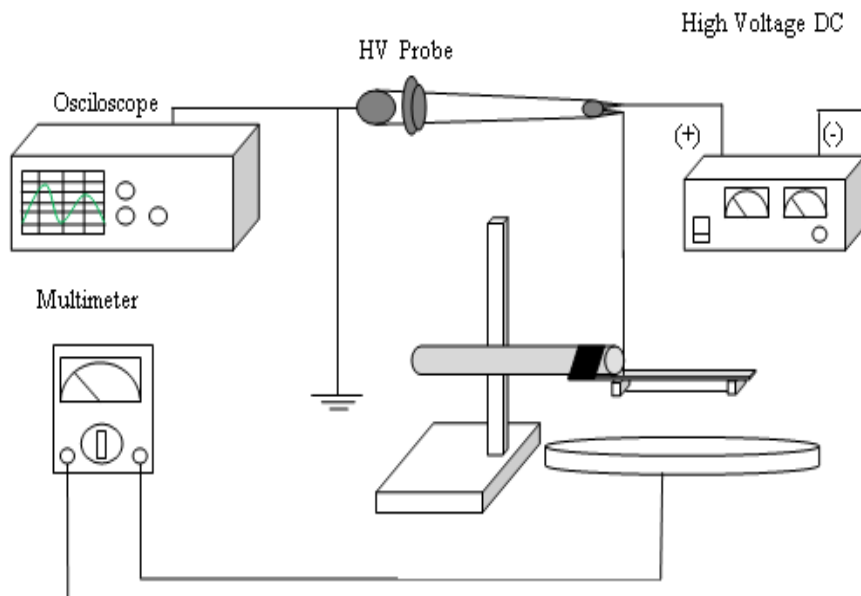

Figure 1. Experimental set up

Corona discharge was generated by DC voltage of 10 kV. The electrical parameters of the corona are determined using a high voltage divider (HV Probe DC max Voltage DC 40 kV; AC 28 kV code number EC 1010, En G1010, SEW high voltage probe P20 P28). Their signals are detected by oscilloscope (Oscilloscope GOS-653, 50 MHz). Current has been measured by Multimeter (Sunwa TRXn 360). Photographs were taken by CCD Camera (Creative, DV Cam 525D). Geometry factor of this experiment was calculated by using the ratio of interelectrode distance and diameter of wire. Distance of electrodes and wire diameter and minor axis of ellipse lubricant oil deformation were measured using a micrometer Mitutoyo Japan measuring tool with precision of 0.01 mm. Angle of ionic wind direction can be determined by $\arctan(\theta_{\max}) = 0.5 \text{ minor axis/distance between wire electrode and plate horizontal electrode}$.

3. Results and Discussion

Current-Voltage Characteristics

Figure 2a, and 2b shows characteristic I-V of positive corona with wire to plate horizontal electrodes configuration. All of our discharge in this experiment, we detect current from tens to more than hundred microamperes (20-180 μA). In this characteristic I-V, we found that Sigmond's unipolar saturation current has been recorded (Sigmond, 1982). In general, this region is called "corona region" in the corona discharge. The same phenomenon has been investigated in argon gas high density and much purified (Nur, 1997). According to Nur, spark and arc region, consider were "bipolar current", that is mean two type (negative and positive electrical charges) as charge carriers has been observed (Nur, 1997). In this region of voltage of this work, we did not detect bipolar current. The characteristics of current as a function of

voltage as shown in figure 2a for condition of in the absence of lubricant oil and Figure 2b in the presence of lubricant on the plane electrode.

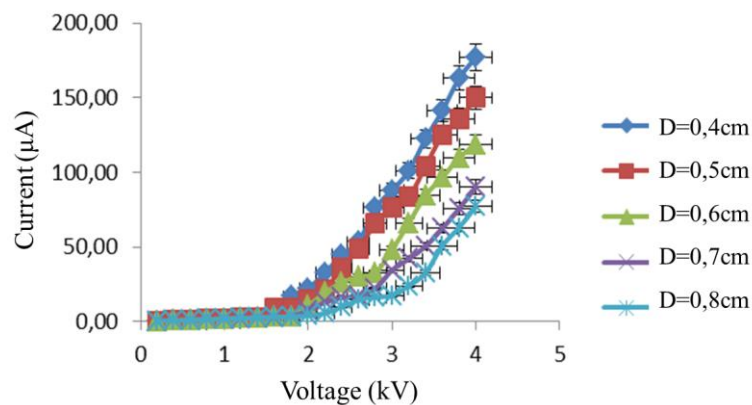

(a)

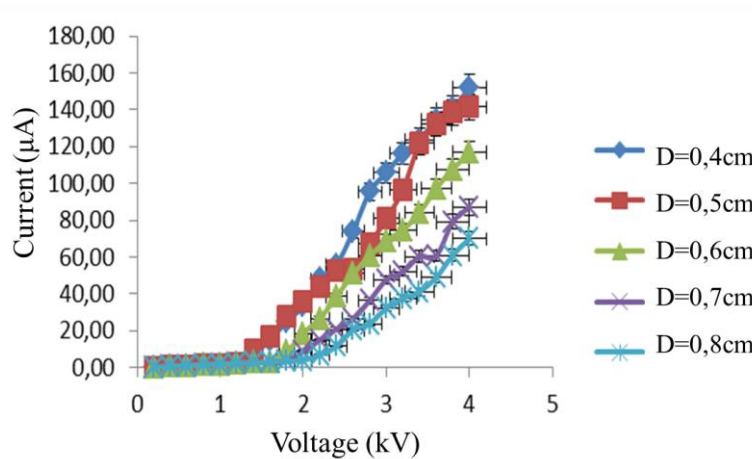

(b)

Figure 2. Characteristics of current as a function of the voltage on the electrode diameter of 0.11 mm
 (a) in the absence of lubricant oil on the plane electrode
 (b) in the presence of lubricant on the plane electrode

Two graphs are for electrode wire diameter of 0.11 mm and the distance between the electrodes 0.4 cm, 0.5 cm, 0.6 cm, 0.7 cm, and 0.8 cm. By comparison of two graph, we found that there are no different current-voltage characteristics. Lubricant oil on the cathode had no effect on the current-voltage characteristics. It can be concluded that the corona wind or Sigmond's unipolar saturation current is caused by the Coulomb force exerted on ions and collisions of ions and neutral molecules of gas.

Figure 2a and 2b shows that current is proportional to the square of the voltage ($I_s \approx V^2$). There are no differences significantly the characteristic of I-V when plane electrode with provision of lubricant oil and without lubricant oil. Positive ions that produced in the surrounding of wire will be rejected by anode and moved towards the cathode. On Figure 2a initial potential difference in each spacing is 0.2 kV. The corona discharge threshold which occurs at a distance between electrodes of 0.4 cm when a voltage was 1.6 kV (threshold voltage). At voltages lower than the threshold (1.6 kV), no substantial current flowed in the air gap. However, over the threshold voltage, averaged discharge current in the order of several ten microamperes was measured and at the same time weak luminescence was observed at the wire electrode. That is, a corona discharge took place. The

current and luminescence were stable and Electrohydrodynamic deformation of lubricant oil surface (see figure 4b). Corona discharge occurs from potential difference of 1.6 kV - 4 kV. When the distance between the electrodes is enlarged, the potential difference needed to reach the threshold of corona discharge will be even greater. This is because the addition of the distance between the electrodes will reduce the value of the electric field (Bamji, et al., 1993). When the electric field decreases the ionization process that occurs around the anode will be reduced and gives an impact for the production of positive ions. The current value of the corona discharge increases with decreasing the distance between the electrodes. Initial voltage at a distance of $D = 0.4$ cm starting at 0.2 kV, for unipolar current value is still very small. Then the voltage is increased until the state is on the corona discharge threshold voltage of 1.6 kV. On the state of the threshold lubricating surface oil began to be deformed. Deformation is characterized by the formation of elliptical holes in the lubricating oil. Similarly to the electrode spacing (D) 0.5 cm, 0.6 cm, 0.7 cm, and 0.8 cm. At $D = 0.5$ cm, corona discharge threshold occurs at 1.6 kV. The condition occurs in 1.8 kV corona - 4 kV corona discharge is still going on. At $D = 0.6$ cm, corona discharge threshold occurs at 2 kV. It is characterized by increase in applied voltage followed by a rise in the value of the current. Kawamoto et. al., reported in EHD base on the discharge in the pin-to-plate system that averaged current-voltage characteristics of ionic wind is similar trend with our results (Kawamoto, 2005).

Current and Geometry Factor Characteristic

Figure 3 shows the graph of the characteristics of electrical current as a function of the geometry factor (ratio of distance interelectrodes and diameter of wire). Data in figure 3a (without lubricant oil) and Figure 3b (with lubricant oil) have been taken for several inter-electrodes distance with wire diameter of 0.11 mm and a voltage of 4 kV.

It can be seen in Figures, 3a, 3b that the value of current decreases linearly with increase of the geometry factor. Unipolar current weakening is due to the greater distance of the electrode, for voltage applied to the electrodes fixed (4 kV). The distance between the electrodes is greater, the smaller the electric field to be generated. This tendency can be explained by the electric field dependence of the distance between the electrodes which have been published by (Bamji, 1993). Furthermore, ionization process will be reduced. Finally the unipolar current of charge carrier should be reduced. Yabe et. al. studied the corona wind experimentally and theoretically from an electrohydrodynamical (EHD) standpoint.

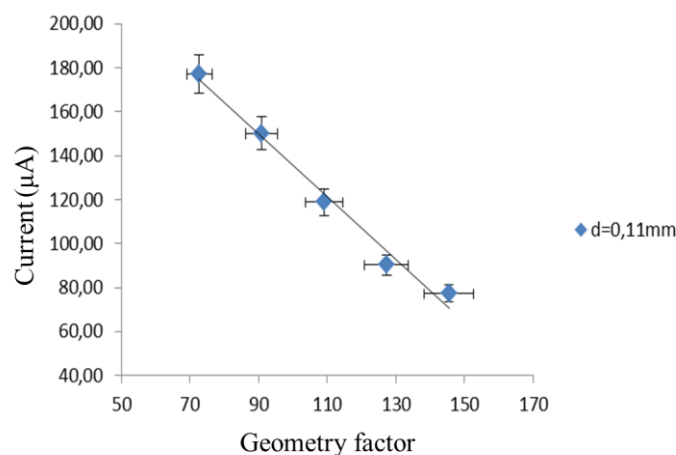

(a)

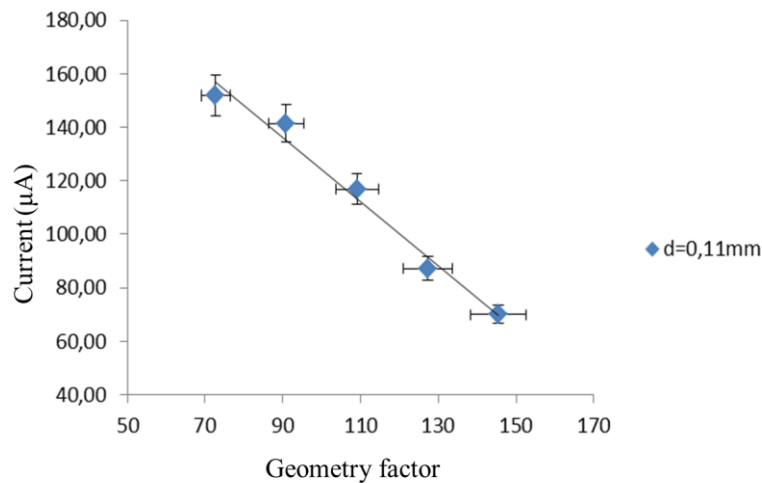

(b)

Figure 3. Characteristics of current as a function of the electrode geometry factor of 0.11 mm diameter wire at a voltage of 4 kV (a) without lubricating oil (b) with lubricating oil

Yabe team used a two-dimensional electrode arrangement of a fine wire anode and a plate cathode. Our results closely with their results that voltage-current characteristics of an electrostatic probe indicate that positive ions predominate in the whole space except in an extremely narrow region close to the wire (Yabe,1978).

Wind Ions direction

Ionic wind generator with configuration of wire to plate horizontal electrodes geometry, initially ionization in surrounding of the wire electrode. Positive ions that have been generated in the ionization zone will be rejected by the electrode wire (positive) and toward the plane electrode (negative). The positive ions moves toward (ionics wind) will make deformation on the surface of the dielectric fluid (lubricating oil). In the lubricating oil, the molecules will form electric dipoles. Figure 4a shows photograph of the lubricating oil without ionic wind and figure 4b photograph presents of ionic wind and we found the deformation of lubricant oil. Direction of wind ions can be determined by measuring characteristic angel (θ_{max}) of wind ions (called wind direction angle). This angel can be found by $\arctan \theta_{max} = 0.5 \text{ minor axis/distance two electrodes}$.

Dielectric fluid movement away from the electrode wire has a width of the minor axis which varies depending on the value of the applied voltage and geometry factors. The voltage and the geometry factor gave influence for value of the angle direction of ionic wind flow. This ionic wind make deformation of lubricating oil surface. Angle of the ion wind flow direction is formed when the voltage applied to the reactor in the zone of corona discharge. It can be assumed that, all charge transport through the gap is carried by charged particles having the same polarity (unipolar). The ions flow lines coincide with the electric field lines, but, the electric field distribution is strongly dependent on the ion space charge. At high currents or corona saturation currents, the density of current distribution as $j(\theta)$ was earlier found by Warburg in 1899, that it closely follows the so called Warburg distribution, given by: $j(\theta) = j(0) \cos^m(\theta)$ with $0 \leq \theta \leq (\theta_{max})$ and $m = 4.82$ for positive corona (Borg, 2004; Sigmond, 1982). At the time of the applied voltage has been included in the zone of corona, the surface of the lubricating oil will form elliptical holes along the electrode wire.

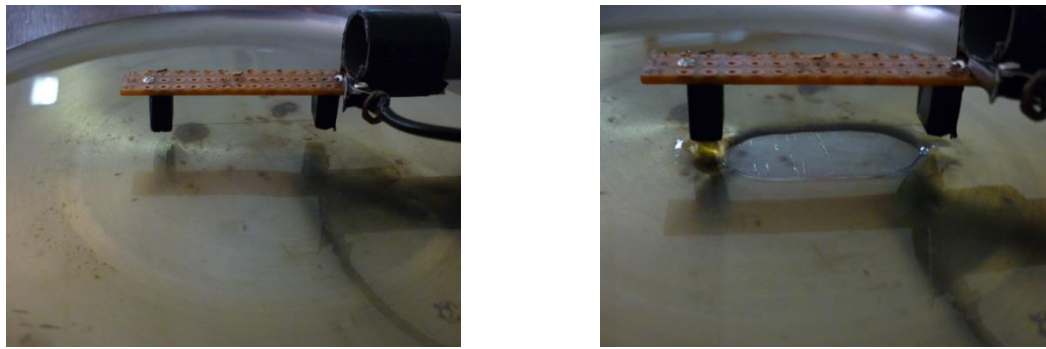

(a)

(b)

Figure 4. Surface of lubricant oil on the electrode plane (a) before the wind ions (b) after the wind ions

Minor axis deformation of the lubricating oil will be growing wide when the voltage applied to the reactor augment. On the other hand, the minor axis will reach a saturation values in the region corona discharge before arc discharge (see figure 5). Dielectric fluid movement away from the electrode wire has a width of the minor axis of which varies depending on the value of the applied voltage and geometry factors. Ion wind flow direction angle is formed when the voltage applied to the reactors already in the category of the corona. At the time of the applied voltage has entered the category corona, surface lubricant will form elliptical holes along the electrode wire. Minor deformation axis will further increase of lubricating oil when the width of the voltage applied to the larger reactor but will reach a saturation point on the value of corona discharge area. Figure 5 is the characteristic angle (as a function of the voltage with a wire diameter of 0.11 mm.

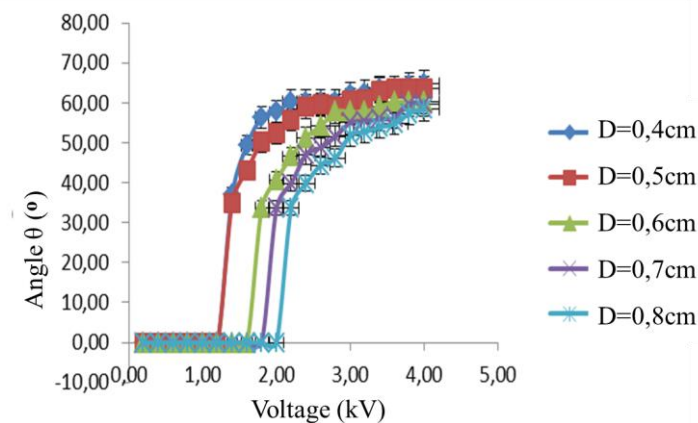

Figure 5. Characteristic angel (θ_{max}) as a function of the voltage on the electrode wire diameter of 0.11 mm
 Characteristic angel of the ionic wind flow direction is marked by the presence of holes or sweeps the surface of the lubricant oil. At a distance of 0.4 cm electrode, deformation lubricant oil begins to form when the voltage of 1.6 kV. At 1.6 kV voltage, the ionic current has been generated with wind direction angle of 36° . The value of this angle increases with increasing the value of the applied voltage. The maximum angle (characteristic angel maximum (θ_{max}^M)) was 65° for a distance of electrode was 0.4 cm and wire diameter of 0.11 mm, with applied voltage of 4 kV. We found the same trend for all distance between two electrodes (0.5 cm, 0.6 cm and 0.7 cm) in this experiment. It is very interesting that the maximum value of the angle direction were observed in all our results were from 59° to 65° . We can see that the angle direction of wind ions is saturation in the certain value, and we called “asymtotic phenomenon” of wind direction in the corona discharge. Figure 6 is an analysis of the characteristic angle as a function of voltage with electrode wire diameter of 0.14 mm, 0.21 mm, 0.36 mm, and

0.38 mm and distance of 0.4 cm between inter electrodes. We found the threshold of ionic wind direction angle was 36° by measuring minor axis elliptical deformation of lubricant oil. The threshold voltage for this characteristic angle was 1.6 kV. The value characteristic angle increases with increasing of the applied voltage. We observed the value of characteristic angle maximum $(\theta_{\max})^M$ was 64.80° with distance of interelectrodes was 0.4 cm and diameter of wire was 0.11 mm. For the 0.5 cm electrode spacing, initial angle formed at 1.6 kV voltage with a value of 34° angle and $(\theta_{\max})^M$ was 63° . Figure 6 shows the increase in the value of the angle the direction of wind flow of ions is increasing with increasing the applied voltage value, but the value of the resulting angle will reach a saturation point in the corona discharge region. Saturation value of the angle that is formed due to the ionic wind is used to deform the amount of lubricant oil remains in the corona region. When approaching the arc discharge, the ions that are formed will undergo recombination so that the number of ions will be reduced. The number of ions is reduced in the area of arc discharge causes the angle formed by the smaller ionic wind. In the figure 6 we can see also that then “asymtotic phenomenon” of ionic wind direction in the corona discharge, in the all condition of experiment in this work.

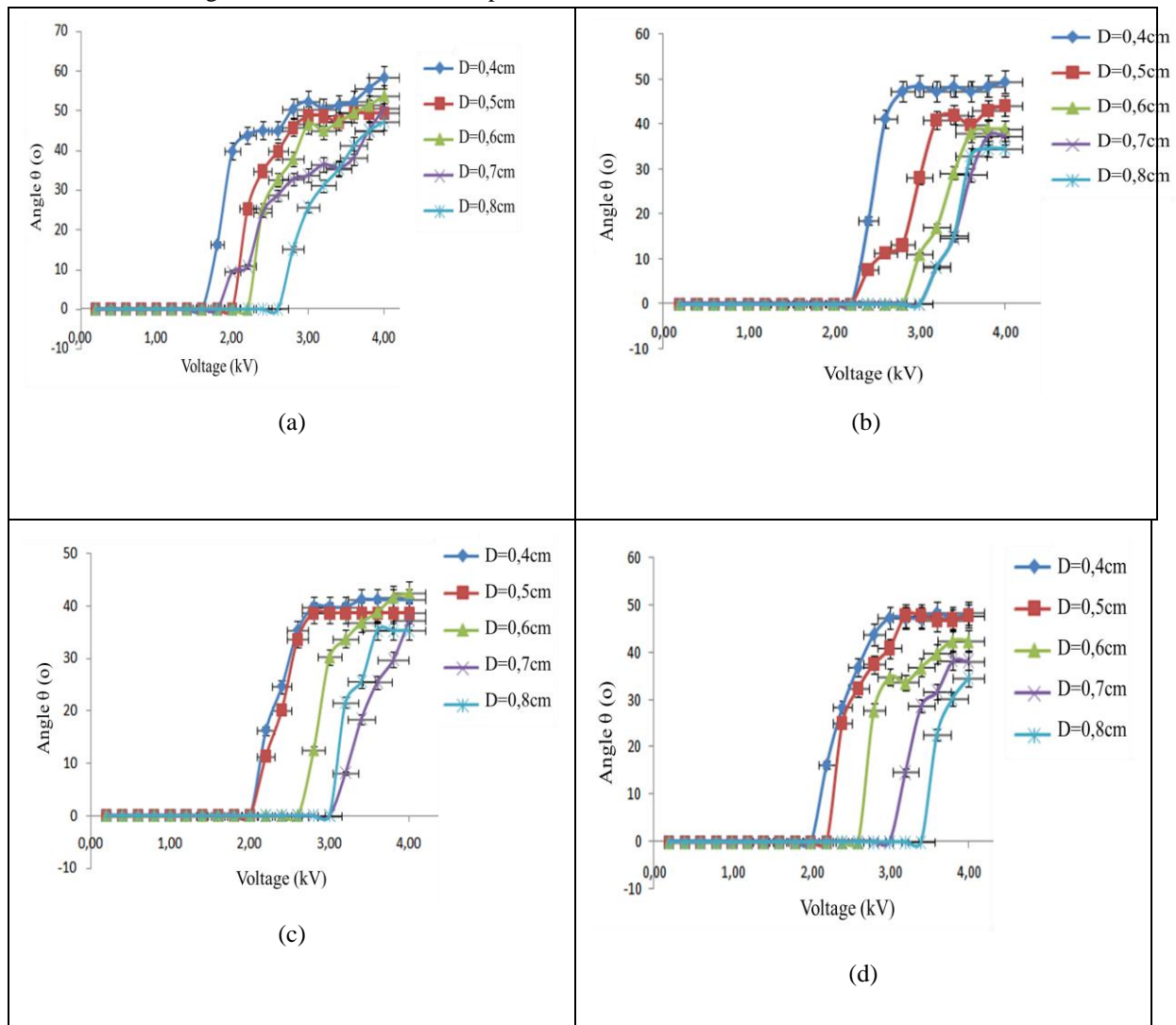

Figure 6. Characteristic angle (θ_{\max}) as a function of the voltage on the electrode wire (a) for the electrode wire diameter of 0.14 mm (b) 0.21 mm diameter wire electrode (c) the electrode wire diameter of 0.36 mm (d) electrode wire diameter 0.38 mm

Value of the ionic wind flow direction angle is inversely proportional to the value of the distance between the electrodes and the value of the diameter of the electrode. From figure 6 the value of the ionic wind flow direction angle gets smaller when the distance between the electrode and the larger the diameter of the electrode wire is used the greater. Figure 7 shows the characteristic of ionic wind angle as a function of the geometry factor with wire electrode diameter of 0.11 mm at a voltage of 3 kV. Ionic wind flow direction angle value is inversely proportional geometry factor (ratio between the interelectrodes distance and diameter of wire).

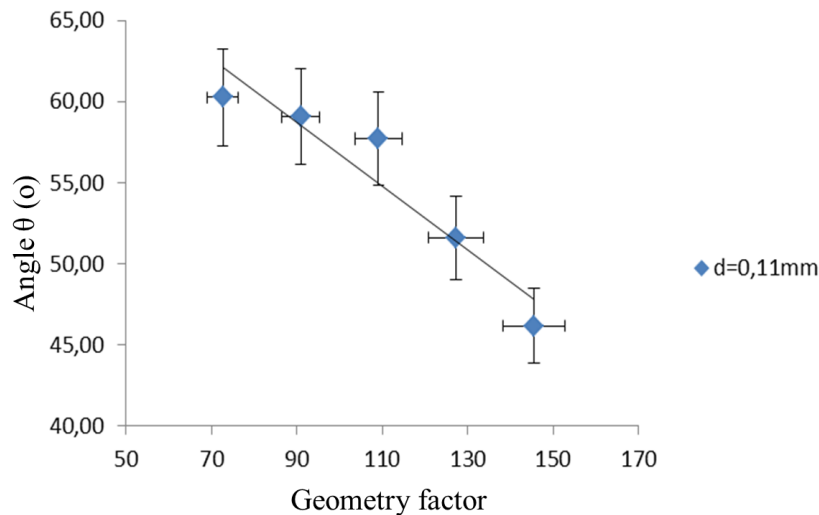

Figure 7. Characteristic angle as a function of the geometry factor of 0.11 mm diameter wire electrodes with voltage 3kV

Ionic wind direction angle value is caused by several factors, such as: The electric field that forms around the electrode wire will affect the ionization process occurs. The larger the electric field, the greater the flow of wind ions generated. The larger the ionic wind is formed, then the minor axis formed in lubricating oil will be even greater. This formed the minor axis is used as a reference for determining the value of the angle of wind ion flow direction. Value of the electric field affected the value of the diameter of the electrode wire and the value of the distance between the electrodes. Figure 7 shows that value characteristic angel of the ionic wind flow direction become small with increasing the geometry factor. This is because when the geometry factor increases the electric field will become small. The production of ions should be decreased with decreasing of electric field.

Reunification Time of Lubricant Oil

Figure 8 shows reunification time of deformation ellipse shaped as function of minox axis of lubricant oil . The data in fogure 8 has been taken from electrohydrodynamics with electrode wire diameter of 0.11 mm and distance between electrodes of 0.4 cm. In figure 8 can be seen the length of time to close the lubricant oil (reunification time) is directly proportional to the lenght of the minor axis deformation ellipse shaped lubricant oil. This deviation is caused lubricant oil exposure to radiation will decrease the value of viscosity. The decline in the value of the lubricant oil viscosity lubricant oil causes closing time will be faster. This applies equally to the diameter of the wire electrode and the distance between the other electrode. Time unification of lubricating oil is obtained from the time of termination outside the electric field when the source voltage is turned off. Minor axis deformation formed lubricant oil affect the time it takes to unify the lubricant oil in its original state. This is due to the current absence of an electric field. The molecules undergo polarization of lubricant oil.

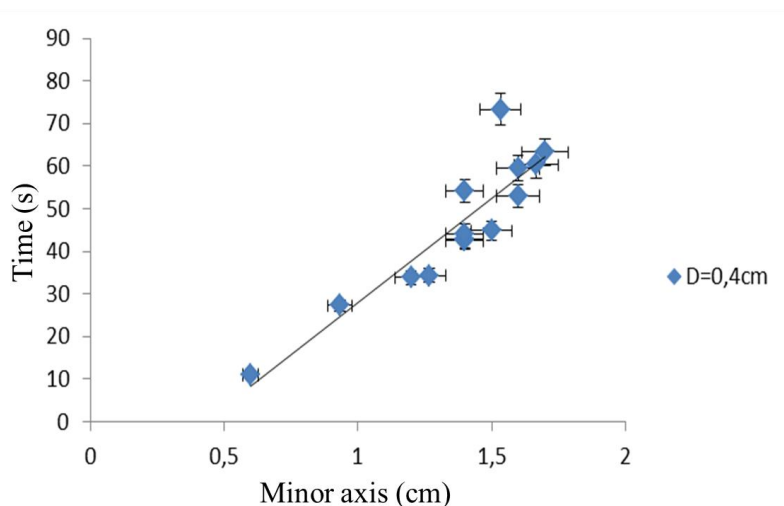

Figure 8. Reunification time of the lubricant oil as a function of minor axis deformation length due to wind ions for wire electrode diameter of 0.11 mm and distance interelectrodes of 0.4 cm

Surface oil has led to the formation of polarization dipoles in lubricant oil. After the source voltage was switched off, positive and negative charges of lubricant oil which forms an electric dipole will be back neutral. The return of the oil to a neutral state which makes lubricant oil will blend back. Apart from the effect of polarization, wind ions also affect the formation of holes in the lubricating oil. Ionic wind is the flow of unipolar ions formed by the ionization that occur around the active electrode. Without external electric field, there is no ionization and ionic wind. The absence of wind ions that cause the lubricant oil is not affected by outside force, so that the lubricant oil will return to its original state.

4. Conclusion

The I-V characteristics of ionic wind was formed parabolic ($I_s \approx V^2$), and ionic wind current also showed an inverse relation with geometry factor. We found that the value of characteristic angle of ionic wind flow direction was depending on field electric value and geometry factor, The maximum value of the angle direction were observed in all our results were from 59° to 65° and the angle direction of wind ions is saturation in the certain value, and we called “asymptotic phenomenon” of wind direction in the corona discharge. Ionic wind flow direction angle value is inversely proportional geometry factor (ratio between the interelectrodes distance and diameter of wire). The deformation of lubricant surface returned to its initial condition after cut off the electric field with time returnee depended on the minor pivot deformation.

Acknowledgments

The authors gratefully acknowledge that part of this research funded by Plasmatech Consulting

References

- Bamji, S.S. Bulinski, A.T. and Prasad, K.M. (1993), Electrical Field Calculation with the Boundary Element Methode, *IEEE Transaction on Electrical Insulation* 8 No. 3
- Boeuf, J. P. Lagmich, Y., Unfer, Th., Callegari, Th. and Pitchford, L. C., (2007), Electrohydrodynamic Force in Dielectric Barrier Discharge Plasma Actuators, *Journal Of Physics D: Applied Physics*, Vol. 40, no.3 652

- Bondar, F. Bastein (1986), Effect of neutral fluid velocity on direct conversion from electrical to fluid kinetic energy in an electro-fluid-dynamics (EFD) device, *J. Phys. D: Appl. Phys.* 19 pp.1657-1663.
- Borg, X., (2004), Full analysis and design solutions for EHD Thrusters at saturated corona current conditions Category: *Ionocrafts & Lifters*, Blaze Labs Research.
- Chattock, A.P. (1899), On the velocity and mass of ions in the electric wind in air, *Philosophy Magazine* 48 401.
- June, M.S., Kribs, J., and Lyons, K.M., (201), Measuring efficiency of positive and negative ionic wind devices for comparison to fans and blowers, *Journal of Electrostatics* 69, pp.345-350
- Kawamoto, H., and Umezu, S., (2005), Electrohydrodynamic Deformation Of Water Surface in a Metal Pin to Water Plate Corona Discharge System, *Journal of Appl. Phys.*, Vol. 38, pp 887-894
- Kim, C. Park, D., Noh, K.C. and Hwang J., (2010), Velocity and energy conversion efficiency characteristics of ionic wind generator in a multistage configuration, *Journal of Electrostatics*, 68, pp. 36–41
- Nur, M., (1997), Etude des décharges couronne dans l'argon et l'azote très purs: transport des charges, spectroscopie et influence de la densité *PhD. Thesis*, Joseph Fourier University, Grenoble, France
- Nur, M., Bonifaci, N. and Denat, A., (2014), Ionic Wind Phenomenon and Charge Carrier Mobility in Very High Density Argon Corona Discharge Plasma, *Journal of Physics.: Conf. Ser.* 495 012041
- Owsenek, B.L. Seyed-Yagoobi, J. (1997), Theoretical and experimental study of electrohydrodynamic heat transfer enhancement through wire-plate corona discharge, *Journal of Heat Transfer* 119 pp. 604-610.
- Robinson, M. (1961), Movement of air in the electric “wind” of the corona discharge, *Trans. Am. Inst. Electr. Engng. Commun. Electron (AIEE J.)* pp. 143-150.
- Sigmond, R.S. (1982), Simple approximate treatment of unipolar spacecharge-dominated coronas: the Warburg law and the saturation current, *Journal of Appl. Phys.* 53 pp 891–898.
- Tanoue, K.I., Masuda, H., and Taniguchi, H., (2006), Experimental study on both ionic wind and resuspension of particles under unequal electrostatic field, *Advanced Powder Technol.*, Vol. 17, No. 1, pp. 69–83
- Yabe, A. Mori, Y. Hijikata, K. (1978), EHD study of the corona wind between wire and plate electrodes, *AIAA Journal* 16 pp 340-345.

The IISTE is a pioneer in the Open-Access hosting service and academic event management. The aim of the firm is Accelerating Global Knowledge Sharing.

More information about the firm can be found on the homepage:
<http://www.iiste.org>

CALL FOR JOURNAL PAPERS

There are more than 30 peer-reviewed academic journals hosted under the hosting platform.

Prospective authors of journals can find the submission instruction on the following page: <http://www.iiste.org/journals/> All the journals articles are available online to the readers all over the world without financial, legal, or technical barriers other than those inseparable from gaining access to the internet itself. Paper version of the journals is also available upon request of readers and authors.

MORE RESOURCES

Book publication information: <http://www.iiste.org/book/>

Recent conferences: <http://www.iiste.org/conference/>

IISTE Knowledge Sharing Partners

EBSCO, Index Copernicus, Ulrich's Periodicals Directory, JournalTOCS, PKP Open Archives Harvester, Bielefeld Academic Search Engine, Elektronische Zeitschriftenbibliothek EZB, Open J-Gate, OCLC WorldCat, Universe Digital Library, NewJour, Google Scholar

