

Designing a Simulation Model for Cardiac Sounds and Checking the Accuracy of the Convertors Used in Microcontroller for This Type of Applications

Mohammad Samer Albaba Dr. Ahmad Alabdo(1) Dr. Eng. Yasser KHADRA (2)

Faculty of Science, physics/ electronics section , University of AL-Baath, Homs, Syria. PO Box 77, Homs, Syria

Abstract

In this research, a computer simulation was carried out using the famous electronic systems simulation program PROTEUS 8 ISIS to design the circuit to collect the heart and chest sounds from the surface of the human body (electronic stethoscope). The audio signal received from the output of the analog Multiplexer was processed using ATmega8 microcontroller. The experimental results were performed on the first cardiac signal S1 using the ADC and DAC circuits used in analog to digital conversion to signal the taking of 20 random samples from the signal.

Keywords: stethoscope, acoustic, Heart sounds, controller, analog to digital convertor, digital to analog convertor.

1. Introduction

The art of evaluating acoustic properties of heart sounds and puffs including intensity, frequency , sharpness and types of the sounds known as process of the auscultation of the heart, it is considered one of the oldest methods for assessing the condition of the heart, especially the function of heart valves. However, the traditional method of auscultation is dominated by the doctor's personal opinion , which adds to the difference in perception and interpretation of sounds, which affects the accuracy of diagnosis [1].

For centuries, European medicine has relied on ancient Greek theory to diagnose the causes of the disease caused by imbalance in the balance of the body's four fluids: blood, sputum, yellow and black-yellow. The knowledge of diseases was then limited. In 1700 a new generation of doctors began to research and reject ancient theories and acquired new knowledge about diseases. After 1800, there was a real change in the doctors' view leading to a medical revolution [2].

Research Objective:

1. Designing an electronic card to obtain the sound signal of the heart and lungs of high performance.
2. Learn about the features and characteristics of the ATmega8 controller used in electronic circuit management.
3. Processing the signal and converting it from digital form to Analog one and preservation it by using processors.
4. Converting the obtained signal from its digital form to its Analog form using the DAC convertor.
5. Ensure accuracy of the DAC convertor manually and determine the maximum error rate during the converting process.

2. Devices and tools:

- 1.4051 Analog Multiplexer
2. LM358 amplifier.
3. ATmega8 Controller .
4. (128 * 64) LCD.
5. Oscilloscope.
6. Various resistors and capacitors.
7. 12V battery.

Stethoscope is a very important device and talking about the traditional stethoscope, it is based physically on the principle of multi-reflection of sound and it is a wave-phenomenon based on the reflection of the sound wave sequentially inside the tube of the stethoscope until it reaches the doctor's examiner's ear but it has many Disadvantages, the most important one is that any friction with the walls of the tube will lead to the occurrence of strange sounds interference and confusion on the hearing process in addition to something else and most importantly that it changes the rate of response to some frequencies without the other, because the frequency response related to the dimensions of the engineering of the headset, including rubber tube[3] .

The heart sounds are considered as low frequencies (115-20) Hz and the lungs sounds frequencies may reach in some cases to 2000 Hz, which means that the examiner doctor must be very skilled to hear and distinguish sounds between them, and here the need arises to use the electronic medical headset as it provides many And many features that serve the diagnostic process because of its importance in diagnosing diseases and chest problems. Low frequency and high frequency filters can be used to pass frequency packets without the

other and thus we can isolate and delete some undesirable signals in their electronic hearing. Simple electronic elements and some amplifiers can be used to amplify the sound to better levels than the traditional stethoscope. Microcontroller processors that can be considered the mastermind can be used for all other processes and features that can be added to the device, such as recording, storing and storing the signal in memory in addition to selecting the frequency packet to be transmitted by giving command to the Analog Multiplexer (4051) and drawing the signal on the LCD. Also easy to carry, light weight and low power.

Obtained the sound wave

A bio-sounding circuit or so-called electronic medical headset can be very simple and can be somewhat complicated. Several things must be considered during the design of the proposed model, the most important of which is that the circuit is more ideal in isolating the signal to pass the preferred frequency band according to the applied filter in addition to noise cancellation, control, recording and storage as mentioned above.

In the proposed model, a simulation model was designed for the circuit of high-performance dynamic sounds consisting of the following elements as shown in Figures (1) (2) (3). The signal obtained by a high-sensitivity capacitor microphone, which takes the function of the bell in the traditional stethoscope, passes through wires to an initial amplifier circuit and then passes the signal to a filter circuit containing 5 filters passing the Analog signal.

The candidate to pass the frequency packet is selected through the 4051 data user. It is driven by a control command using an ATmega8 microcontroller, which in turn converts the signal from Analog to digital format and store it in memory.

The circuit designed with a 12Volt battery is fed in order to eliminate the city current problems during the hearing (noise and interruptions) process.

Filtration stage

One of the most important and difficult processes to comply with the design of an electronic headset is to determine the frequency range to be passed for a particular set of sounds to be distinguished. It is better to divide the vibration spectrum of the sound fields. In Heart Phonocardiography (PCG), the fields under the sound are taken into account.

The vibration spectrum can be divided into domains as follows [4]:

1. From 0-5 Hz. This band of vibrations corresponds to the visible and easily palpable motions of the chest wall. It includes the apex beat, the epigastric beat, and several other motions of various intercostal spaces.
2. From 5–25 Hz. This band includes the vibrations which are now called low-frequency vibrations. It barely overlaps the audible range been particularly studied by means of electromagnetic pickups. This band is partly infrasonic (5-15 Hz) and partly subliminal (15-25 Hz); therefore, it is partly in that range where large vibrations may be perceived by the human ear.
3. From 25-120 Hz. This band was studied by Mannheimier [8]. It was reproduced by the (stethoscopes) method of Rappaport and Sprague [9, 10].
4. From 120-240 Hz. It corresponds to the best area of recording of most apparatus and is in the auditory range.
5. From 240-500 Hz. It corresponds to a fairly good area of recording of many apparatus. It is approximately represented by the (logarithmic) method of Rappaport and Sprague [9].
6. From 500-1000 Hz. This large band corresponds already to the area of the spectrum where sounds originating in the heart and recorded from the chest wall are of extremely reduced magnitude.
7. From 1000-2000 Hz. This band is usually subliminal on account of poor magnitude of the vibrations. Only two apparatus seem able to record vibrations due to cardiac dynamics, in a few normal subjects and in some cardiac patients.

In our proposed model, a filtration system was constructed, as in Figure (3), consisting of 5 circuits. It was chosen to include all frequency bands containing high frequency and low frequency sounds in accordance with the available electronic components in the local market. Figure (3) shows that the output of each filter phase connected to the 4051 data selector was selected to select one, and results were obtained very close to the frequency bands allowed to pass in the Heart Phonocardiography.

The cut-off value for each filter was calculated using the following relationship:

$$f_c = \frac{0.707}{2\pi RC} \quad (1)$$

$$f_{c1} = \frac{0.707}{2\pi RC} = \frac{0.707}{2 \times 3.14 \times 4.7 \times 10^3 \times 220 \times 10^{-9}} = 108.8 \approx 120 \text{ Hz}$$

$$f_{c2} = \frac{0.707}{2\pi RC} = \frac{0.707}{2 \times 3.14 \times 4.7 \times 10^3 \times 100 \times 10^{-9}} = 293.5 \approx 240 \text{ Hz}$$

$$f_{c3} = \frac{0.707}{2\pi RC} = \frac{0.707}{2 \times 3.14 \times 4.7 \times 10^3 \times 47 \times 10^{-9}} = 509.6 \approx 500 \text{ Hz}$$

$$f_{c4} = \frac{0.707}{2\pi RC} = \frac{0.707}{2 \times 3.14 \times 4.7 \times 10^3 \times 22 \times 10^{-9}} = 1088.7 \approx 1000 \text{ Hz}$$

$$f_{c5} = \frac{0.707}{2\pi RC} = \frac{0.707}{2 \times 3.14 \times 4.7 \times 10^3 \times 10 \times 10^{-9}} = 2395 \approx 2000 \text{ Hz}$$

It should be noted here that the calculated cut frequencies are very close to the main areas selected as a reference due to the accuracy and quality of the elements used in the local market as mentioned above.

Microcontroller and its properties

Micro-controller is a small computer designed for command and control so that it does not require additional external components for its main operation. The infrastructure often contains the contents of the computer, meaning that the controller contains CPU, ALU, EEPROM, RAM and data inputs and exits. The power consumption of a microcontroller is very small compared to ordinary computers, and most controllers are built on this basis. But the controllers may differ depending on the specifications and characteristics of these contents, in addition to the fact that sometimes there are special features of some controllers may be made for special purposes [5]. Although the Micro-controller is small in size, it is complex, so the mechanism in which the program interacts with the existing hardware must be understood. In our design, we will use the ATmega 8 microcontroller, which is suitable for the applications needed for our operation because it contains a good number of properties [6].

The ADC convertor on the ATmega8 microcontroller

Which is responsible for the conversion of the Analog signal coming from the output of the voter data to convert this signal to the digital form And perform the necessary mathematical processes, processing and saving in the memory of the controller, and also has a good number of properties Figure (4) shows the ATMEGA8 pin description [6].

Digital / Analog convertor DAC

The digital to Analog convertor is a tool that converts the digital signal to an Analog signal and works in contrast to the Analog digital convert. There are many DAC structures, where the DAC is selected for a particular application by six main parameters: physical size, power consumption, resolution maximum sampling, accuracy and cost. There are several types of these switches, the most important of which is:

Digital / Analog convertor using resistors network 2R-R

Figure (5) shows the digital / Analog switch using the 2R-R resistor network used in the simulation model with 10 inputs for binary numbers and analog output expressed in the corresponding voltage value for each digital input The general power equation can thus be defined as shown in relation (2)[7]:

$$I_{sum} = I \left(\frac{D_9}{2} + \frac{D_8}{4} + \frac{D_7}{8} + \frac{D_6}{16} + \frac{D_5}{32} + \frac{D_4}{64} + \frac{D_3}{128} + \frac{D_2}{256} + \frac{D_1}{512} + \frac{D_0}{1024} \right) \quad (2)$$

The output voltage by relation (3):

$$V_{out} = -I_{sum} \times R_s \quad (3)$$

Results can be set in Table (1).

3. Experimental results

In this research, we made measurements on the first sound signal of the heart S1 after it reached the ATmega8 controller from the analog multiplexer output to select the filter to pass its own signal without the rest of the filters.

Where Analog / digital convertor located within the control structure do the conversion process to indicate the next to the digital signal in the form of a binary number corresponds to the value of the voltage of the reference in each sample, and the rate of sampling is consistent with the accuracy of the conversion at 1024 value here.

Figure (6) shows the S1 signal on the oscilloscope in the famous program proteus 8 isis, in its Analog form, where the sensitivity of the amplitude is set to the value of 0.5 V for channel B. The time sensitivity was set to 5ms for the same channel.

We took the previous graph and performed a manual holding of the samples from the previous signal, in an Analog form, sampling the length of the signal reach 20 samples for different points and taking the corresponding voltages on a voltage range of 5Volt. Note that the ADC circuit on the ATmega8 controller takes a reference voltage value $V_{ref} = 5\text{volt}$ [6]. Figure (7) shows the voltage values for each sample where each voltage value represents V_{in} , for each sample to be converted to a binary number using relation (4):

$$N_D = \frac{V_i}{V_{cc}} \times 1024 \quad (4)$$

The calculation produces a specific decimal number converted to a binary system number that will receive a value for the electrical sample voltage that was capture.

For sample 1, using the approximation rules we find:

$$N_D = \frac{2.8}{5} \times 1024 = 573.44 \approx 573$$

The value 573 for sample (1) corresponds to the binary value (1000111101). The conversion from the Analog to the digital form is done using the ADC circuit for all signal samples. After converting the signal to the digital format, it is stored in the ATmega8 controller memory to perform the computational calculations performed on it and then called back to the control output and from it to the circuit output. Here the role of the DAC circuit is the digital / Analog convertor that takes the digital signal and put it on the input of the 2R-R balanced resistor network used in this research to be converted to Analog signal again. The 2R-R circuit was used with 10 entries from(D0 --- ----- D9)

Table (2) shows the results obtained for Analog / digital conversion Table (3) shows the digital / Analog conversion of previous binary values.

From the results we can note that the conversion process is carried out in high precision with an error not exceeding Volt 0.002 and can be neglected compared to the reference voltage field of the ADC. This is what distinguishes the accuracy of the convertor in general.

4. Conclusion

1. The stethoscope is a very important medical tool in clinical medical diagnosis, it includes multiple physical components.
2. The frequency range of heart and lung sounds is of great importance in the quality of diagnosis.
3. The traditional stethoscope gives the doctor an ability to hear all the frequency areas of the heart and lungs and add to that the interference resulting from these sounds, which adds to the additional difficulty on the ability of the doctor to diagnose and this is a defect of the traditional stethoscope.
4. The process of dividing the frequency domain of the heart and lungs sounds makes the listening process easier. In this way, high frequency sounds are isolated from low-frequency sounds and vice versa, which helps the doctor in the clinical diagnosis process. This is difficult to apply to traditional stethoscope, but its applicability to electronic systems is possible.
5. The processor of ATmega8 controller is capable of performing all calculations and logic operation on the sound signals of the heart and lungs digitally using the ADC convertor circuit.
6. The 2R-R resistor network used to convert the signal to its Analog form with 10 inputs gave excellent results and this compared to the ADC signal within the ATmega8 controller with an error of only 0.2% which could be neglected. And can be removed permanently using programmed digital filters.

5. References

- [1] NEW THORACIC MURMURS WITH TWO NEW INSTRUMENTSE REFRACTOSCOPE AND THE PARTIAL STETHOSCOPE. BY FREDERICK D. PARKER 1918 (From the Laboratory of Dr. Frederick D. Parker. ' M.D.
- [2] an approach to the ideal stethoscope 'David Littmann 'M.D. 'West Roxbury 'Mass '1961.
- [3] Sound Waves and Music - Physics of Musical Instruments Closed-End Air Columns. 2014
- [4] Phonocardiography Signal Processing 'Abbas K. Abbas 'Rasha Bassam 'SYNTHESIS LECTURES ON BIOMEDICAL ENGINEERING #31 '2009.
- [5]. Introduction to Microcontrollers, G. Jack Lipovski ' 'Academic Press 'USA '1999
- [6] ATmega 8/L , datasheet , 8-bit Atmel with 8KBytes In System Programmable Flash , Rev.2486AA–AVR–02/2013
- [7] 4-bit digital to analog converter using R-2R ladder and binary weighted resistors J. Diosanto al 2017 IOP Conf. Ser.: Earth Environ. Sci. 69 012194.
- [8]. E. Mannheim, Standardization of phonocardiography, Proc. of Second European Congress of Cardiology, 1956.
- [9]. B. G.Wells, RappaportM. B., Sprague H. B., The sounds and murmurs in contraction of the aorta: a study by auscultation and phonocardiography, Am. Heart J., Jul. 38(1):69-79, 1949. DOI: 10.1016/0002-8703(49)90793-0
- [10]. Bill Gardner and Keith Martin, HRTF Measurements of a KEMAR Dummy-Head Microphone, MIT Media, Aug, 2000.

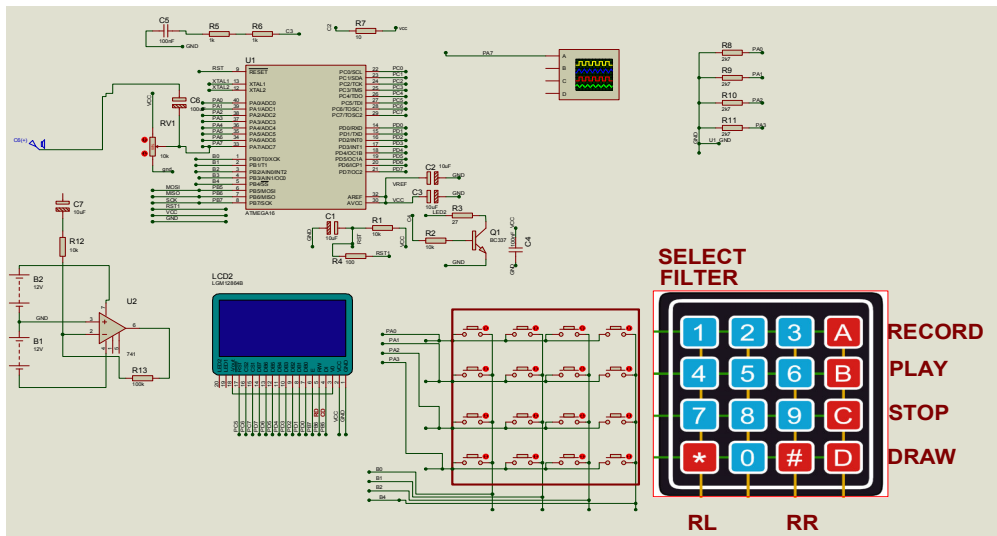

Figure 1:Signal monitoring section

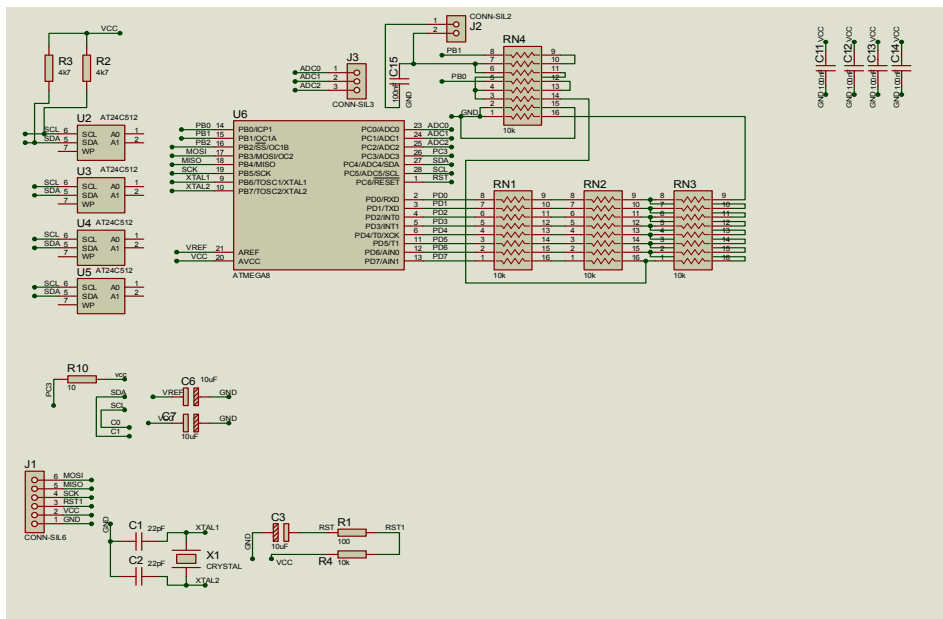

Figure 2: Microcontroller circuit

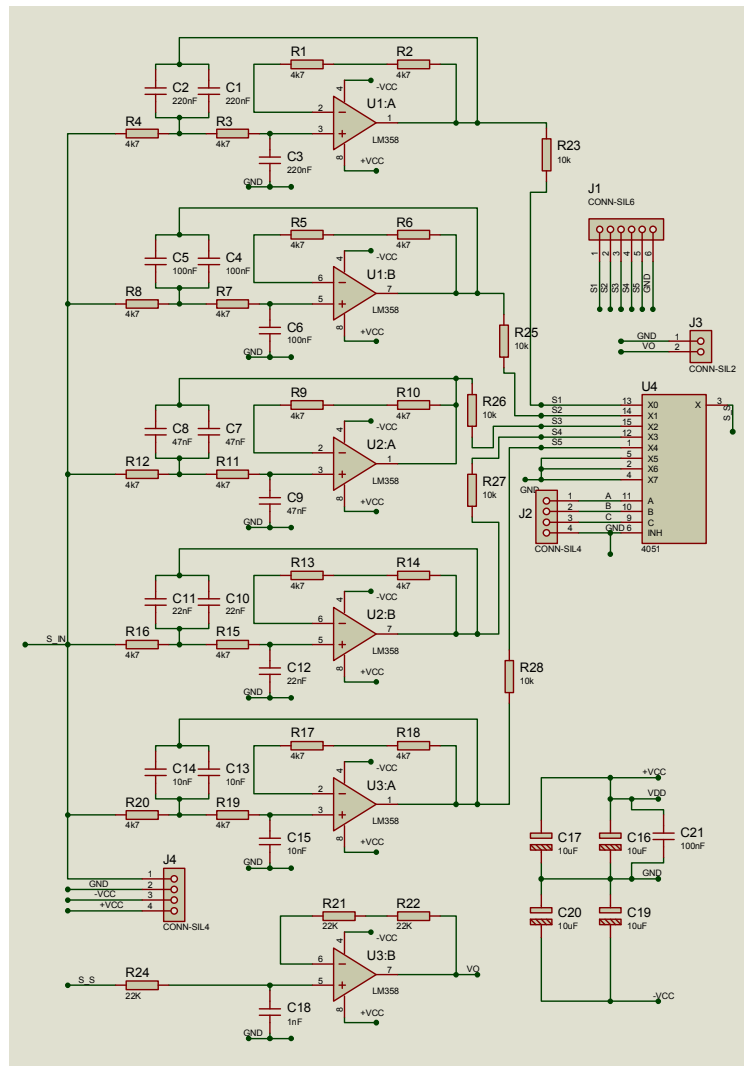

Figure 3: Filtering stage which include 5 filters

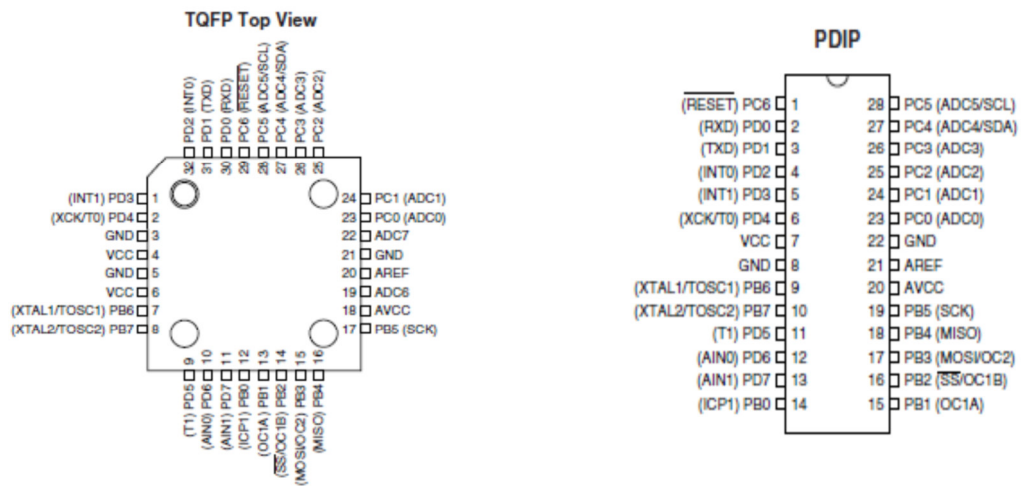

Figure 4: ATMEGA8 pin description

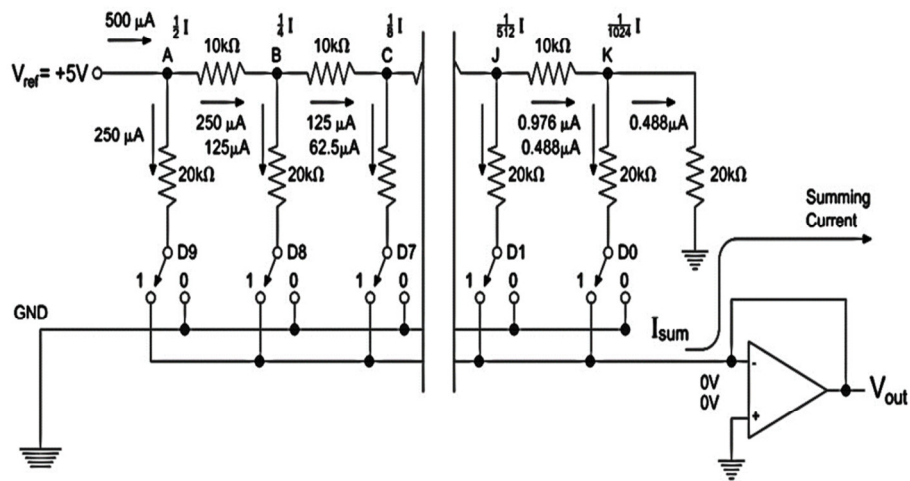

Figure 5: 2R-R circuit with 10 input

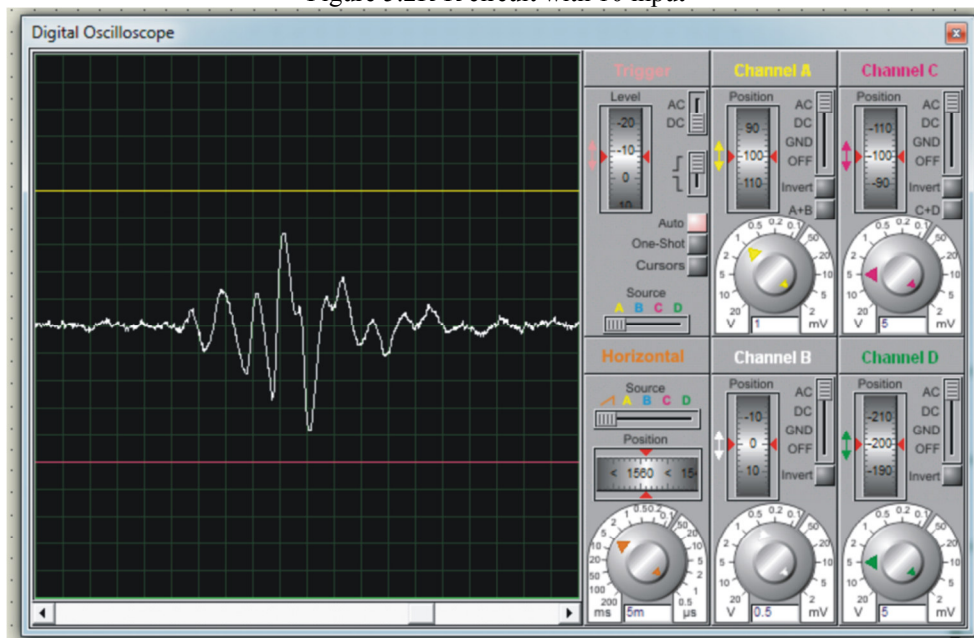

Figure 6: Generated heart sound signal S1

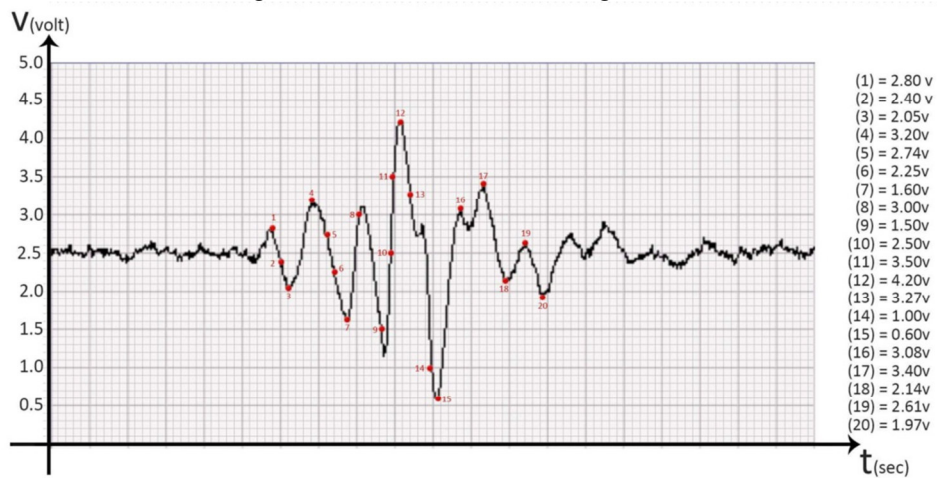

Figure 7: Holding samples for heart sound signal S1

Table 1: Output voltage for 2R-R circuit with 10 input

	D9	D8	D7	D6	D5	D4	D3	D2	D1	D0	V out
0	0	0	0	0	0	0	0	0	0	0	0.000
1	0	0	0	0	0	0	0	0	0	1	0.005
2	0	0	0	0	0	0	0	0	1	0	0.010
3	0	0	0	0	0	0	0	0	1	1	0.015
4	0	0	0	0	0	0	0	1	0	0	0.020
5	0	0	0	0	0	0	0	1	0	1	0.024
6	0	0	0	0	0	0	0	1	1	0	0.029
7	0	0	0	0	0	0	0	1	1	1	0.034
8	0	0	0	0	0	0	1	0	0	0	0.039
9	0	0	0	0	0	0	1	0	0	1	0.044
10	0	0	0	0	0	0	1	0	1	0	0.049
.
.
.
1013	1	1	1	1	1	1	0	1	0	1	4.946
1014	1	1	1	1	1	1	0	1	1	0	4.951
1015	1	1	1	1	1	1	0	1	1	1	4.956
1016	1	1	1	1	1	1	1	0	0	0	4.961
1017	1	1	1	1	1	1	1	0	0	1	4.966
1018	1	1	1	1	1	1	1	0	1	0	4.971
1018	1	1	1	1	1	1	1	0	1	1	4.976
1020	1	1	1	1	1	1	1	1	0	0	4.980
1021	1	1	1	1	1	1	1	1	0	1	4.985
1022	1	1	1	1	1	1	1	1	1	0	4.990
1023	1	1	1	1	1	1	1	1	1	1	4.995
1024	1	1	1	1	1	1	1	1	1	1	5.000

Table 2: Analog to digital convertor for 20 sample

sample	V_i (volt)	ND	ND(using approximation rules)	binary value
1	2.8	573.44	573	1000111101
2	2.4	491.52	492	0111101100
3	2.05	419.84	420	0110100100
4	3.2	655.36	655	1010001111
5	2.74	561.152	561	1000110001
6	2.25	460.8	461	0111001101
7	1.6	327.68	328	0101001000
8	3	614.4	614	1001100110
9	1.5	307.2	307	0100110011
10	2.5	512	512	1000000000
11	3.5	716.8	717	1011001101
12	4.2	860.16	860	1101011100
13	3.27	669.696	670	1010011110
14	1	204.8	205	0011001101
15	0.6	122.88	123	0001111011
16	3.08	630.784	631	1001110111
17	3.4	696.32	696	1010111000
18	2.14	438.272	438	0110110110
19	2.61	534.528	535	1000010111
20	1.97	403.456	403	0110010011

Table 3: Digital to analog convertor for binary values		
binary value	V_{out}(using DAC)	$\Delta V = V_i - V_{out}$
1000111101	2.798	0.002
0111101100	2.402	0.002
0110100100	2.051	0.001
1010001111	3.198	0.002
1000110001	2.739	0.001
0111001101	2.251	0.001
0101001000	1.602	0.002
1001100110	2.998	0.002
0100110011	1.499	0.001
1000000000	2.5	0
1011001101	3.501	0.001
1101011100	4.199	0.001
1010011110	3.271	0.001
0011001101	1.001	0.001
0001111011	0.601	0.001
1001110111	3.081	0.001
1010111000	3.398	0.002
0110110110	3.139	0.001
1000010111	2.612	0.002
0110010011	1.968	0.002