

Microcontroller Based Green House Control Device

Alausa Dele W.S

Mnse, Mniem, Ancs, Maes, Coren Regd, Department Of Computer Engineering, the Federal Polytechnic, Ilaro
Alausa2008@gmail.com

Keshinro Kazeem Kolawole

Mnse, Ncs, Coren Regd, Department Of Computer Engireeng, Lagos State Polytechnic, Ikorodu
keshinrokk2002@yahoo.com

Abstract

MICROCONTROLLER BASED Green House control device is used in the automatic control and monitoring of Equipments and quantities such as screening installations, heating, cooling, lighting, temperature, soil Moisture level and other quantities/conditions in a Green House, with effective monitoring of all quantities therein, hence eliminating need for Human monitoring. With an enhanceable feature it integrates and automates by turning ON or OFF all monitoring devices in the house as well as provides suggestions for remedies when the need arises. This is due to the MCU technology that can be easily modified and re-modified with portability. There is also an alarm circuit to call the attention of the Supervisor. This study focuses on determining the effectiveness and functionality of green house control device.

Keywords: green house, ventilation, heating, watering, temperature, radiation

1.0 INTRODUCTION

A greenhouse is a building in which plants are grown for commercial or research purposes. These structures range in size from small sheds to very large buildings, with different types of covering materials, such as a glass or plastic roof and frequently glass or plastic walls; it heats up because incoming visible solar radiation (for which the glass is transparent) from the sun is absorbed by plants, soil, and other things inside the building. Air warmed by the heat from hot interior surfaces is retained in the building by the roof and wall. In addition, the warmed structures and plants inside the greenhouse re-radiate some of their thermal energy in the infrared spectrum, to which glass is partly opaque, so some of this energy is also trapped inside the glasshouse. However, this latter process is a minor player compared with the former (convective) process. Thus, the primary heating mechanism of a greenhouse is convection. Ventilation is one of the most important components in a successful greenhouse. If there is no proper ventilation, greenhouses and their plants can become prone to problems (Zagade, Kawitkar, 2012). The main purposes of ventilation are to regulate the temperature to the optimal level, and to ensure movement of air and thus prevent build-up of plant pathogens (such as *Botrytis cinerea*) that prefer still air conditions. Ventilation also ensures a supply of fresh air for photosynthesis and plant respiration, and may enable important pollinators to access the greenhouse crop. Ventilation can be achieved via use of vents - often controlled automatically - and recirculation fans.

Embedded green house monitoring and control is proposed to provide a highly detailed micro-climate data for plants within a greenhouse environment with an innovative method of growing temperate crops in a tropical environment using microclimatic conditions. The greenhouse was equipped with conventional wired sensors that provide readings of the air temperature, light intensity and nutrient solution temperature in the mixing tank. The acidity and concentration of the nutrient solution were manually measured, and adjusted accordingly, and high resolution data, collected with the deployment of a network of wireless sensors to provide sufficient data to develop a model for the growth of these crops under aeroponic conditions (Leong et al., 2009).

The proposed system is an embedded system which will monitor and control the microclimatic parameters of a greenhouse on a regular basis round the clock for cultivation of crops or specific plant species which could maximize their production over the whole crop growth season and to eliminate the difficulties involved in the system by reducing human intervention to the best possible extent using sensors, Analog to Digital Converter, microcontroller and actuators (Stipanicev, Marasovic 2003). When any of the above mentioned climatic parameters cross a safety threshold which has to be maintained to protect the crops, the sensors sense the change and the microcontroller reads this from the data at its input ports after being converted to a digital form by the ADC (Leong et al., 2009). The microcontroller then performs the needed actions by employing relays until the strayed-out parameter has been brought back to its optimum level. Since a microcontroller is used as the heart of the system, it makes the set-up low-cost and effective nevertheless. As the system also employs an LCD display for continuously alerting the user about the condition inside the greenhouse, the entire set-up becomes user friendly. Thus, this system eliminates the drawbacks of the existing set-ups and is designed as an easy to maintain, flexible and low cost solution (Kiran et al., 2012).

2.0 IMPORTANCE OF GREEN HOUSE

Greenhouses protect crops from too much heat or cold and help to keep out pests(Gill et al., 2006). Light and temperature control allows greenhouses to turn in arable land into arable land, thereby improving food production in marginal environments because greenhouses allow certain crops to be grown throughout the year, greenhouses are increasingly important in the food supply of high latitude countries(Thomas et al., 2001). One of the largest greenhouse complexes in the world is in Almeria, Spain, where greenhouses cover almost 50,000 acres (200 km²). It is sometimes called the sea of plastics.

2.1 PROBLEM AND SOLUTION ENCOUNTERED ON GREEN HOUSE

Irrigation is the important thing on a greenhouse system. The water we provide, which is the main element will make sure the plants survive on certain circumstances. As we all know, most of the gardener use the manual system to irrigate their plant but this system is not efficient. The plants will either die if there is not enough water supplies to the plant or vice versa. Plus the gardener must often monitor their greenhouse to ensure the conditions of their plant are in the good health.

In order to maintain the condition and overcome the problem, the automatic watering system and remote monitoring is used. This will reduce the time if using automatic rather than manual way of watering. Fewer workers are needed to maintain the plants or crops. The sensors such as temperature sensor (Thermistor) and soil moisture probe are used to control the temperature and watering in the greenhouse. (Kenneth, 1998).

3.0 METHODOLOGY

This project involved the implementing of a green house control device in order to control, monitor and maintain the desired temperature in the green house by turning ON the Heater/cooling system as when due also study the soil moisture content (when water is needed) by turning the water valve ON or OFF.

3.1 DESCRIPTION OF THE DEVICE

The block diagram below shows how the inputs section is connected into the microcontroller through an arrow, the arrow indicate that data is passing through the microcontroller. The output section is connected out of the microcontroller through the arrow. Furthermore, the input section are assign to their own pins in the microcontroller and processed to give an output, while output section are assign to their own pins in the microcontroller, to archive the construction of green house control device.

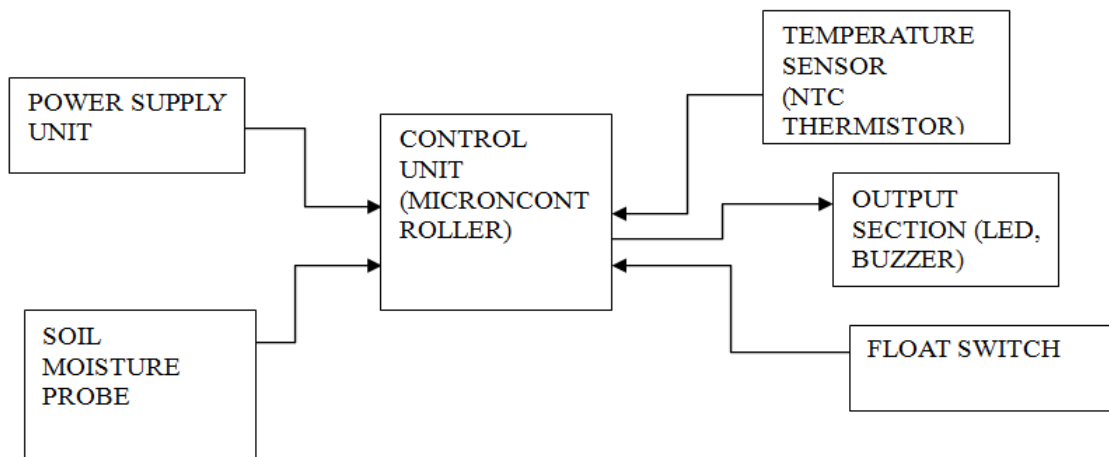

Fig 1: Shows the block diagram of a green house control device.

3.2 VARIOUS UNITS OF THE DEVICE

This unit consists of an AC power supply unit, well rectified into DC and further regulated to 5v respectively. The system comprises of rectified 5v with the AC or a 9volts battery, since the operating voltage of all the units is 5volts, a Thermistor, measuring the temperature of the surrounding or anybody brought near the sensor, a pair of black and red probe used to determine the result of the output section, the co-ordinating section, and an output section made of devices like LEDs, Buzzer. This entire device works based on the instruction sent to them by the CPU to carry out a specific operation in maintaining or correcting a condition(Kiran et al, 2012).

Transducers

A transducer is a device which measures a physical quantity and converts it into a signal which can be read by an observer (Kiran et al, 2012). The sensors used in this system are:

1. Light Sensor (LDR (Light Dependent Resistor))
2. Humidity Sensor
3. Temperature Sensor

Analog to Digital Converter

In physical world parameters such as temperature, pressure, humidity, and velocity are analog signals. A physical quantity is converted into electrical signals. We need an analog to digital converter (ADC), which is an electronic circuit that converts continuous signals into discrete form so that the microcontroller can read the data. Analog to digital converters are the most widely used devices for data acquisition.

Analog world	Transducer	Signal Conditioning	Analog to Digital Converter	Microcontroller
--------------	------------	---------------------	-----------------------------	-----------------

Fig. 2: Getting data from the analog world

Microcontroller (*pic16f873A*)

The microcontroller is the heart of the proposed embedded system. It constantly monitors the digitized parameters of the various sensors and verifies them with the predefined threshold values. It checks if any corrective action is to be taken for the condition at that instant of time. In case such a situation arises, it activates the actuators to perform a controlled operation.

Liquid Crystal Display

A liquid crystal display (LCD) is a thin, flat display device made up of any number of color or monochrome pixels arrayed in front of a light source or reflector. Each pixel consists of a column of liquid crystal molecules suspended between two transparent electrodes, and two polarizing filters, the axes of polarity of which are perpendicular to each other.

Relays

A relay is an electrical switch that opens and closes under the control of another electrical circuit. In the original form, the switch is operated by an electromagnet to open or close one or many sets of contacts. Because a relay is able to control an output circuit of higher power than the input circuit, it can be considered to be, in a broad sense, a form of an electrical amplifier.

Power Supply Connection

The power supply section consists of step down transformers of 230V primary to 9V and 12V secondary voltages for the +5V and +12V power supplies respectively.

SOFTWARE

MPLAB: The MPLAB is an integrated development environment used to create software to be run on embedded systems (like a microcontroller). It allows for such software to be written either in assembly or C programming languages and for that software to be simulated on a computer before being loaded onto the microcontroller.

Device Database: It contains information, about more than 400 supported microcontrollers.

Peripheral Simulation: The MPLAB provides complete simulation for the CPU and on chip peripherals of most embedded devices.

Programmer

The programmer used is a powerful programmer for the PIC series of microcontrollers. Major parts of this programmer are Serial Port, Power Supply and Firmware microcontroller. Serial data is sent and received from 9 pin connector and converted to/from TTL logic/RS232 signal levels by MAX232 chip. A Male to Female serial port cable, connects to the 9 pin connector of hardware and another side connects to back of computer.

3.2.1 CENTRAL PROCESSING UNIT

This unit is solely made up of a Microcontroller and its circuitry, the MCU accepts all inputs from its input ports/transducers, process the inputs commands and sends out the required output through its output ports to the output devices.

The microcontroller is available only in 28 pins packages, I/O ports are port A, B, C, each ports are assign its own features; Port A pin 2 to pin7, Port B pin 21 to pin 28, Port C pin 11 to pin 14, pin 15 to pin 18.

Each ports and pins are used to perform the input and output operations in other to archive the desired goal (green house control circuit). Additional functions may include A-D converters, serial communication, flash program memory and more.

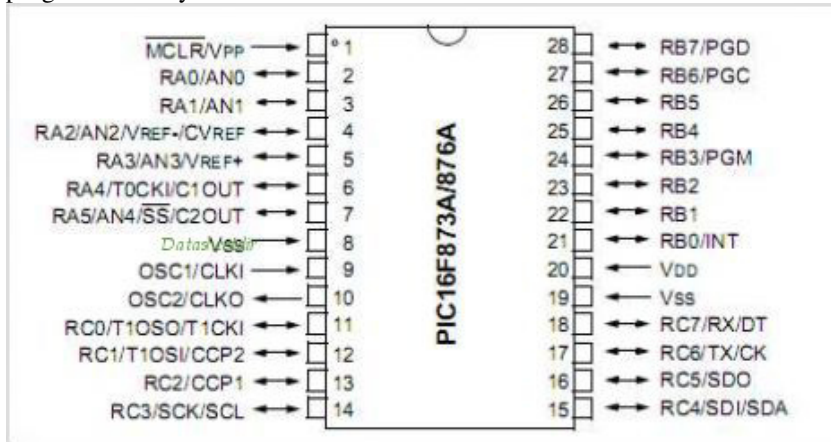

Fig 3: Shows pin-out of the microcontroller pic16f873A

3.2.2 INPUT SECTION

This unit is made up of Input devices like Thermistor, Soil Moisture Probe and Float Switch to measure and monitor the required quantities/conditions. The thermistor is connected to the microcontroller through Port A pin 3 RA1/AN1, the soil moisture probe is connected to Port A pin 2 RA0/AN0, power supply +5v VDD to microcontroller pin 1 MCLR/Vpp and float switch is connected to the microcontroller Port C pin 11 of RC0/T1OSO/T1CK1. This unit sends the results to the CPU for further processing and performing of the solutions.

3.2.3 OUTPUT SECTION

This unit is made up of output devices like LEDs, Buzzer, water valve, Heater control Unit. The buzzer is connected to Port B pin 22 RB1 of the microcontroller buzzes on the instruction of the CPU, Its function is to raise an Alarm, the LEDs is connected to microcontroller Port B pin 24 RB3/PGM as water valve and pin 27 RB6/PGC as heater. This entire device works based on the instruction sent to them by the CPU to carry out a specific operation in maintaining or correcting a condition.

4.0 CONSTRUCTION AND TESTING

4.1 CONSTRUCTION OF THE MICROCONTROLLER CIRCUITRY

The Microcontroller sockets were soldered onto the Vero Board, and then soldered were the 4MHz crystal oscillator and 33pF ceramic capacitor to the socket's pin 18 and 19 respectively. Also, soldered were the wires to all the input and output pins on the socket so as to aid easy linking of the central processing unit to the other peripheral units.

4.2 CONSTRUCTION OF THE INPUT AND OUTPUT SECTION

The input devices were connected to the appropriate pins of the Microcontroller, so also the output devices. The microcontroller's output was connected to the BC 547 Transistor with 10 kilo ohms resistor to reduce the flow of current into the transistor. Then the collector leg of the transistor was connected to the negative terminal of the 12v buzzer and the emitter leg to the ground of the circuit respectively. The transistor serves as a switch; it switches ground to the buzzer as soon as it is biased by the microcontroller.

The positive terminal of the buzzer is connected to the output of the power supply unit.

4.3 TESTING

The physical realization of this work was carried out to achieve the conceived idea. Here the work will be seen not just on paper but also as a finished hardware. After carrying out all the paper design and analysis, the hardware was implemented and tested to ensure it's working ability and was finally constructed to meet desired specification (Kiran et al, 2012).

SOIL MOISTURE

Tolerance= ± 0.2 V at 27°C

TABLE 1: SOIL MOISTURE SENSOR READINGS

Soil Condition	Transducer Optimum Range
Soil is dry	0V
Optimum level of soil	1.9- 3.5V
Moisture Slurry soil	>3.5V

LIGHT Tolerance = ± 0.1 V

TABLE 2: LIGHT SENSOR READINGS

Illumination Status	Transducer Optimum Range
OPTIMUM ILLUMINATION	0V-0.69V
DIM LIGHT	0.7V-2.5V
DARK	2.5V- 3V
NIGHT	3V-3.47V

HUMIDITY

Tolerance= ± 0.1 V

$\text{RH} = ((V_{\text{out}} / V_{\text{cc}}) - 0.16) / 0.0062$, typical at 25°C where, $V_{\text{supply}} = 4.98$ V

TABLE 3: HUMIDITY SENSOR READINGS

Percentage RH(RELATIVE HUMIDITY)	Transducer Optimum Range
0%	0-0.8V
0% to 9.81%	0.8-1.1V
12.9% to 20.1%	1.2-1.45V
22.7% to 30.06%	1.5-1.725V
30.8% to 40.5%	1.75-2.05V
41.3% to 50.3%	2.075-2.35V
51% to 60.02%	2.375-2.65V
61.6% to 70.5%	2.7-2.975V
71% to 80.2%	3-3.275V
81.1% to 90%	3.3-3.6V
91% to 100%	3.6-3.9V

TEMPERATURE

Temperature ($^{\circ}\text{C}$) = $(V_{\text{out}} / 5) * 100$ ($^{\circ}\text{C} / \text{V}$)

TABLE 4: TEMPERATURE SENSOR READINGS

Temperature range in degree Celsius	Temperature sensor output(V_{cc})
10°C	0.5V
10° to 20°C	0.5-1.0V
20° to 30°C	1.0-1.5V
30° to 40°C	1.5-2.0V
40° to 50°C	2.0-2.5V
50° to 60°C	2.5-3.0V
60° to 70°C	3.0-3.5V
70° to 80°C	3.5-4.0V
80° to 90°C	4.0-4.5V
90° to 100°C	4.5-5.0V

4.4 IMPLEMENTATION AND PROCEDURE

The implementation of this work was done on the breadboard. The power supply was first derived from a bench power supply in the laboratory. (To confirm the workability of the circuits before the power supply stage was soldered).

Stage by stage testing was done according to the block representation on the breadboard, before soldering of circuit commences on Vero board. The various circuits and stages were soldered in tandem to meet desired workability of the hardware.

Three general steps were followed to appropriately select the control system (Kiran et al, 2012):

Step # 1: Identify measurable variables important to Production.

Step # 2: Investigate the control strategies using threshold sensors that directly affect actuation of devices.

Step # 3: Identify the software and the hardware to be used considering factors such as reliability, support, previous experiences with the equipment (successes and failures), and cost.

4.5 PROGRAMMING OF THE MICROCONTROLLER

The microcontroller controls all the activities of other devices and all other components are connected as input and output peripherals to it. The Microcontroller is programmed to always check on the input port from the input devices, this aid continuous monitoring and efficient maintaining of the required conditions.

Step 1:

Writing of the source code using Notepad.

Step 2:

Assembling of the Source Code to Machine Code (Object code)

The source code is assembled using ASM-4 assembler; the assembler assembled the source code successfully without errors. Separating the HEX file to be burned to the Microcontroller.

Step 3:

Burn the HEX files to the Microcontroller using a universal programmer and a Turbo Link program. After burning of the HEX files to the Microcontroller, eject the chip from the programmer.

4.6 RESULT AND DISCUSSION

The design result was achieved when the thermistor (NTC) is connected to the microcontroller through Port A pin 3 RA1/AN1 as input, outputting through Port B pin 27 RB6/PGC as heater or temperature. When the temperature is above 20°C the voltage across the thermistor will be greater than 1.4v the LED will turn ON, when the temperature is below 20°C the voltage across the thermistor will be less than 1.4v, the LED OFF. The soil moisture probe is connected to Port A pin 2 RA0/AN0 as input, outputting through Port B pin 24 RB3/PGM as water valve. When Pin 2 (RA0/AN0) is pulled up to 5v, the moisture probe is placed in water (i.e. moisture is present in the soil) there will be a resistance across the probe thereby developing a voltage across the probe, as such the voltage on that (RA0/AN0) pin 2 will reduce below 5v.

When the voltage drops below 5v the moisture LED will be OFF, but when there is no moisture in the soil the LED come ON indicating a dry soil. The float switch is connected to the microcontroller Port C pin 11 of RC0/T1OSO/T1CK1 and it can be set up to sense either rising or falling water levels - rising water to measure when a container is full or water has reached a certain maximum level, falling water to measure when a container is empty or has reached a certain minimum level.

5.0 CONCLUSION

A step-by-step approach in designing the microcontroller based system for measurement and control of the four essential parameters for plant growth, i.e. temperature, humidity, soil moisture, and light intensity, has shown that the system performance is quite reliable and accurate. This will reduce the time of using the manual way of watering. Fewer workers are needed to maintain the plants or crops. The sensors such as temperature sensor (Thermistor) and soil moisture probe are used to control the temperature and watering in the greenhouse. The system has successfully overcome quite a few shortcomings of the existing systems by reducing the power consumption, maintenance and complexity, at a reduced cost and at the same time providing a flexible and precise form of maintaining the environment.

REFERENCES

- Stipanicev D., Marasovic J. (2003). Network embedded greenhouse monitoring and control. *Proceedings of 2003 IEEE Conference on Control Applications*.
- PIC microcontroller Data Sheet, Microchip.
- SENSORS- The Journal of Applied Sensing Technology, Advanstar Communications Inc.
- S.U. Zagade, R.S. Kawitkar (2012). Wireless Sensor Network for Greenhouse. *International Journal of Science and Technology*, Volume 2 No.3, ISSN 2224-3577
- Thomas, Andrew L. and Richard J. Crawford, Jr. (2001). *Performance of an energy-efficient, solar-heated greenhouse in southwest Missouri*. Southwest Missouri Agricultural Research and Education Center 2001 Research Report. University of Missouri-Columbia.
- Gill, S., R.A. Cloyd, J.R. Baker, D.L. Clement, and E. Dutky(2006). *Pests & Diseases of Herbaceous Perennials: The Biological Approach*. Ball Publishing Co., Batavia, IL.
- Kenneth M. Chomitz (1998). *Baselines for greenhouse gas reductions: Problems, precedents, solutions*. Development Research Group, Carbon Offsets Unit.

Kiran Sahu, Susmita Mazumdar (2012). Digitally Greenhouse Monitoring and Controlling of System based on Embedded System. International Journal of Scientific & Engineering Research, Volume 3, Issue 1, ISSN 2229-5518.

Leong Boon Tik, Chan Toong Khuan, Sellappan Palaniappan(2009). *Monitoring of an Aeroponic Greenhouse with a Sensor Network*. International Journal of Computer Science and Network Security. Vol.9.

The IISTE is a pioneer in the Open-Access hosting service and academic event management. The aim of the firm is Accelerating Global Knowledge Sharing.

More information about the firm can be found on the homepage:

<http://www.iiste.org>

CALL FOR JOURNAL PAPERS

There are more than 30 peer-reviewed academic journals hosted under the hosting platform.

Prospective authors of journals can find the submission instruction on the following page: <http://www.iiste.org/journals/> All the journals articles are available online to the readers all over the world without financial, legal, or technical barriers other than those inseparable from gaining access to the internet itself. Paper version of the journals is also available upon request of readers and authors.

MORE RESOURCES

Book publication information: <http://www.iiste.org/book/>

Academic conference: <http://www.iiste.org/conference/upcoming-conferences-call-for-paper/>

IISTE Knowledge Sharing Partners

EBSCO, Index Copernicus, Ulrich's Periodicals Directory, JournalTOCS, PKP Open Archives Harvester, Bielefeld Academic Search Engine, Elektronische Zeitschriftenbibliothek EZB, Open J-Gate, OCLC WorldCat, Universe Digital Library, NewJour, Google Scholar

