

An Approach towards Data Protection as a Service Intended for Cloud Masses

Sarah Najm Abdulwahid
Dept of MSc Is, Osmania university, Hyderabad, A.P, India

Abstract

The Cloud is a database of numerous data which is accumulated , adjusted or recovered by clients . By Cloud Service Provider users may receive services of pay per use. There are many services, like quick access to data , scalability , data storage , data recovery ... etc which can profit customers . Cloud service providers are responsible of the security and protection of their customers' data which moves online and vast data centers. Thousands of requests and hundreds of millions of users can benefit from securities added to single cloud platform. Protecting data requires various sophisticated tools, mechanisms and activities.

Keywords: Data protection as a service, cryptographic defenses, single cloud platform.

1- Introduction

Cloud, via concentrating memory, bandwidth and processing, provide additional net services. Cloud is a database where users accumulate, recover and adjust data on the basis of pay per use. Cloud technology has developed in its infrastructures permitting users to make applications devoid of installation by means of internet access to the personal files. These applications are internet services provided by servers. Some of the advantages of Cloud computing are on-demand self-service , ubiquitous network admission , location autonomous resource pooling , fast resource elasticity , usage-based charge ...etc . Providing the utmost consumption requires the use of the resources of cloud architecture . An investigation showed that more than 50% of users and 80% of businessmen are motivated by Cloud opportunities , safety , accessibility and protection of data . The platform can attain financial prudence of scale by different applications and designs. Cloud platform provides data security away from data encryption which allows rich calculations related to proficiency and resources.

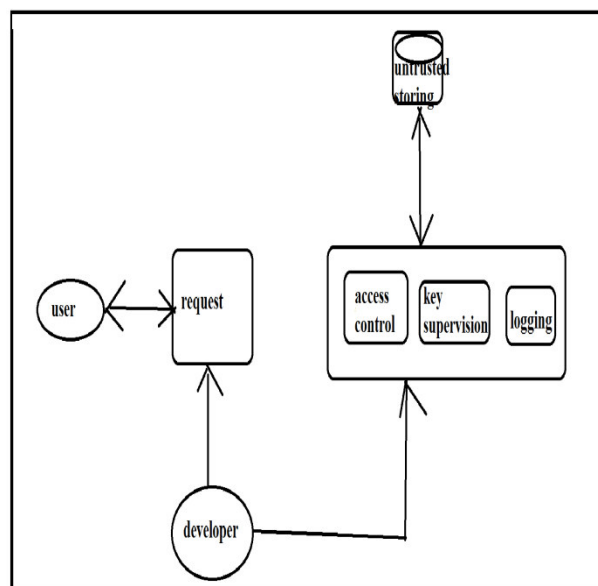

2- Methodology

Now , users may use on legal contracts to obtain substitutions . However , Cloud platform helps to obtain practical resolution to inscribe sustainable requests which defend data ; thus , users can develop advance self-assurance that their data is controlled in a proper way . Cloud platform deal with partitions of applications work out on data units permitting at the same time considerable computational latitude within these partitions . Figure 1 shows how data is protected through control mechanisms of fine-grained access by quarantine and information flow examination . Cryptographic defenses , vigorous logging and auditing are employed . Hence , rapid expansion and maintenance of data are addressed . Data protection is provided as a service added to the hosting environment; small companies which lack internal safety proficiency may benefit from this service. Access control is a major component of the Cloud. Official users and applications can confine visibility with autonomy of actions. This creates relaxation for programmers in secure systems for quarantine builds tricky intended for

buggy codes to let data flows or to find out illegal admission of data . Finding out when data is accessed , by whom or what means that data is handled properly ; revealing , at the same time , the inappropriate usage or penetrations .

3- Goals of Data Protection and Development :

Cloud is a central database where users can gather , recover or adjust their data on the basis of pay per use . Improving a single data-protection resolution for the cloud is not possible because it should focuses on applications like email , private sector administration , commercial and social activities ...etc . The measures of applications are : delivering services to a large number of users , data processing and administration , data sharing with tracking applications , job planning , user verification and the base software background . A basic principle in a solution of platform-layer is to create rapid development and preservation. A useful solution should imply data protection, improvement and preservation. Confirmation is simple since users will be able to confirm what platform is running and whether the cloud guarantees confidentiality. On the other hand, the platform permits organized and affluent computations on data. As for expansion and support, designers will obtain expansion and maintenance support in their efforts to find and hit bugs. Reliability and secrecy are maintained since deposited data is not despoiled and no data is penetrated by unlawful objects. Finally, logs will find out who retrieve several data.

4- Conclusion

Cloud motivates delivery of services with speed and good quality. In addition to data protection via a mixture of encryption application of internment and information examination, thousands of requests and users can obtain various benefits. The platform performs through code packing, endorsement and significant organization with a runtime confirmation to this consequence. Liabilities and conciliations are segregated within each secure environment; data flow inspection protects the safety and security of data especially when it interchanges online. It handles data in huge centers uses shared safety proficiency.

REFERENCES

- [1]. E. Naone, "The Slow-Motion Internet," *Technology Rev.*, Mar./Apr. 2011; www.technologyreview.com/files/54902/GoogleSpeed_charts.pdf.
- [2]. L. Whitney, "Microsoft Urges Laws to Boost Trust in the Cloud," *CNET News*, 20 Jan. 2010; http://news.cnet.com/8301-1009_3-10437844-83.html.
- [3]. C. Dwork, "The Differential Privacy Frontier Extended Abstract," *Proc. 6th Theory of Cryptography Conf. (TCC 09)*, LNCS 5444, Springer, 2009, pp. 496-502.
- [4]. A. Greenberg, "IBM's Blindfolded Calculator," *Forbes*, 13 July 2009; www.forbes.com/forbes/2009/0713/breakthroughs-privacy-super-secret-encryption.html.
- [5]. C. Gentry, "Fully Homomorphic Encryption Using Ideal Lattices," *Proc. 41st Ann. ACM Symp. Theory Computing (STOC 09)*, ACM, 2009, pp. 169-178.
- [6]. A. Sabelfeld and A.C. Myers, "Language-Based Information- Flow Security," *IEEE J. Selected Areas Comm.*, Jan. 2003, pp. 5-19.
- [7]. P. Maniatis et al., "Do You Know Where Your Data Are? Secure Data Capsules for Deployable Data Protection," *Proc. 13th Usenix Conf. Hot Topics in Operating Systems (HotOS 11)*, Usenix, 2011; www.usenix.org/events/hotos11/tech/final_files/ManiatisAkhawe.pdf.
- [8]. M.S. Miller, "Robust Composition: Towards a Unified Approach to Access Control and Concurrency Control," PhD dissertation, Dept. of Philosophy, Johns Hopkins Univ., 2006.
- [9]. S. McCamant and M.D. Ernst, "Quantitative Information Flow as Network Flow Capacity," *Proc. 2008 ACM SIGPLAN Conf. Programming Language Design and Implementation (PLDI 08)*, ACM, 2008, pp. 193-205.