

# A Microcontroller Framework for PC Based Electrical Appliance Control System

Ganiyu Adedayo. Ajenikoko, Timothy O. Araoye, Akinniyi T. Akintayo, Dare E. Oyekunle  
Isiah I. Olugbemiga

Department of Electronic & Electrical Engineering, Ladoke Akintola University of Technology, P.M.B. 4000,  
Ogbomoso, Nigeria.

## Abstract

Personal computers are increasingly becoming the platform of choice to design and implement control algorithms because it is simple to write, modify and update software programs that implement control algorithms.

In this paper, the personal computer is used to control the electrical appliances which includes turning high power alternating current (AC) loads such as lights, fans, heaters etc ON or OFF. To successfully integrate the interface box with the machine (laptop), an interface device is used within the PC that can perform the necessary tasks. The interface box can be controlled by the computer by connecting to the USB port and developed a program in C-sharp(C#) programming language. The program will demonstrate the basic idea of how to control devices and monitor events. With the program, the computer can turn electric devices ON/OFF while disregarding the manual control system. Moreover, the people who are physically disabled in homes and work places are able to control the home appliances by interacting with the interface of the developed appliance. It is a necessity to employ the service of Home Appliances Control as it is more effective, efficient and stress-free.

**Keywords:** Personal Computers, Home Control Appliance, Distribution Fuse Board (DFB), Graphical User Interface (GUI), Interface Box, Internal Module, Enumeration, Local Area Network (LAN).

## 1. Introduction.

A Personal computer (PC) based home control appliance is the use of control systems at homes, in the offices and in industries to reduce human efforts. Home control appliances have greatly decreased the need for human sensory and mental equipments and plays an important role in the world economy and in daily experience. It is more efficient and stress-free (Coyle et al 2007).

Home and office appliances, including television, VCRs, stereo equipment, refrigerators,, washing machines, thermostat, light switches, telephones, copiers and factory equipment, have embedded computers and often come with remote controls. However, the trend has been that as appliances get more computerized with more features, their user interfaces get harder to use (Dickey et al 2012).

PCs are commonly used with better input-output capability than the average home appliance, such as high-resolution screens, text-entry technologies and speech capability. PC.s are likely to maintain this advantage over appliances, because improved hardware is a key differentiator between PC and is often marketed as an incentive to upgrade to a new PC. All PC has the ability to communicate over the Local Area Network (LAN) and most have built-in short range communication capabilities, such as Bluetooth, that could allow them to communicate with and control appliance in their surrounding environment. PC laptops are also personal devices, which allow them to provide interface that are personalized (Koyuncu 1995, Nunes and Delgado 2000, Sriskanthan and Tan 2002).

### 1.1 The brain of the system.

The brain of the system is actually a small computer whose job is to close the switch that activates the switches that powers sensing devices when ON or OFF. Home based PC differs mainly in Distribution Fuse Board (DFB) and how various home appliances are wired in to the brain. The brain and the DFB features may be wired into the control room, but they usually have a back-up power source as well. The architecture of the PC home based appliances control system is shown in Figure 1.

The system consists of two units(Swamy et al 2002, Nichols and Myers, 2006):

- I Control unit: The control unit is based on the use of standard personal computer with Graphical User Interface (GUI ) software to control the electrical appliances.
- ii Interface unit: The interface unit is for interfacing the high power loads with the control unit.

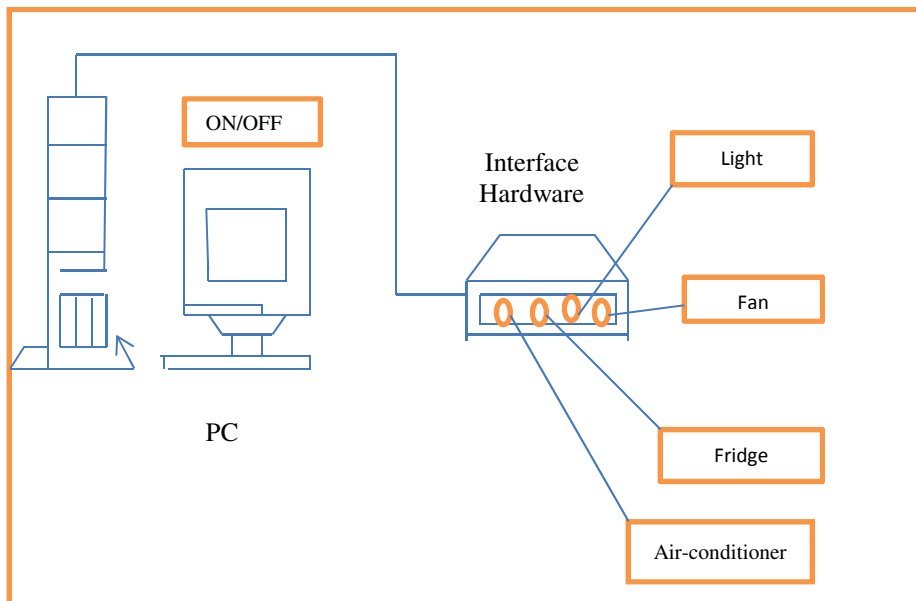

Figure 1: Architecture of the PC home based appliances control

### 1.2. Hardware Design of the Interface Box

The design of the interface box that is used to connect high power load to the computer is discussed here.

#### Internal module

The internal circuitry of the interface box can be divided into three main categories namely: relay driver circuit, relay and +6 V DC power supply.

#### Computer Interfacing

The Universal Bus (USB) is one of the most common interfaces used in electronic consumer product today, including PCS, cameras, GPS devices, MP3 players, modems , printers and scanners, to mention a few. These are data lines, control lines and status lines. The USB is a high-speed serial interface that can provide power to device connected to it(Kim et al 2010, Lin and Broerg 2002, Neng-Shiang et al, 2002). A USB bus supports up to 127 devices (limited by the 7-bit address field noting that address 0 is not used as it has a special purpose) connected through a four-wire serial cable of three to five meters long. Many USB devices can be connected to the same bus with hubs, which can have 4, 8, or even 16 ports. A device can be plugged into a hub which is plugged into another hub and so on. The maximum number of tiers permitted is six. According to the specification, the maximum distance of a device from its host is about thirty meters, accomplished by using five hubs. For longer-distance bus communications, other methods such as use of Ethernet are recommended.

The USB bus specification comes in two versions: the version USB 1.1, supporting 11Mbps, while the version, USB 2.0 supports up to 480Mbps. The USB specification defines three data speeds(AI-Ali and AI-Rousan 2004, Kobatake et al 1989).:

- i. Low speed ---- 1.5Mb/sec.
- ii. Full speed----- 12Mb/sec.
- iii. High speed ----- 480Mb/sec.

The maximum power available to an external device is limited to about 100mA at 5.0V. USB is a four- wire interface implemented using a four-core shielded cable. Two types of connectors are specified and used, Table 1 shows typical USB connectors and Table 2 shows the pin-out of the USB connectors. The signal wire colors are specified. The specification also defines a mini-B connector, mainly used in smaller portable electronic devices such as cameras and other handheld devices. This connector has a fifth pin called ID, though this pin is not used. The pin assignment and wire colors of a mini-B connector are given. Two of the pins, Data + and Data -, form a twisted pair and differential data signals and some single- ended data states.

Table 1: USB pin configuration

Pin no	Name	Color
1	+5.0V	Red
2	Data-	White
3	Data+	Green
4	Ground	Black

Table 2: USB pin assignment

Pin no	Name	Color
1	+5.0V	Red
2	-Data	White
3	+Data	Green
4	Not Used	-----
5	Ground	Black

### Enumeration

When a device is plugged into a USB bus, it becomes known to the host through a process called enumeration. The steps of enumeration are (Anamal and Kamruzzaman 2006, Casimiro et al 2004):

- i. When a device is plugged in, the host becomes aware of it because one of the data line voltages (Dp or D) becomes logic high.
- ii. The host sends a USB reset signal to the device to place the device in a known state. The reset device responds to address 0.
- iii. The host sends a request on address 0 to the device to find out its maximum packet size using a Get Descriptor command.
- iv. The device responds by sending a small portion of the device descriptor.
- v. The host sends a USB reset again.
- vi. The host assigns a unique address to the device and sends a Set Address request to the device.

### 2. Materials and method

The design demonstrates a system that allows one to control home appliance and turns ON or OFF any appliance that is connected to a computer. The appliances are connected to the computer via a microcontroller. The power supply for each appliance is through an electromechanical relay. A number of relays are used depending on the number of appliances to be controlled. All the relays are controlled by a microcontroller. The microcontroller is connected to the computer via a USB to RS232 Converter. The diagram below in Figure 2 shows the block diagram of the system.

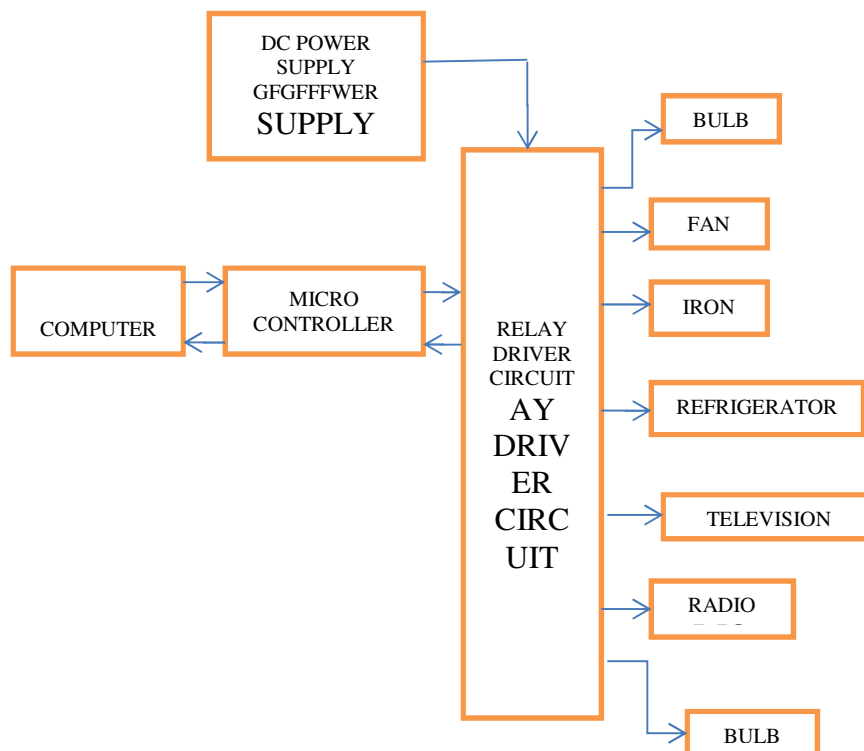

Figure.2: Block Diagram of the designed system

#### 2.1. Approach to Development of the Framework

The basis of the hardware design is mainly the PIC16F876A microcontroller using micro C pro compiler. Two circuit diagrams were developed. These are:

- i. Power supply regulation circuit
- ii. Main component circuit

### 2.1.1 Power Supply Regulation Circuit

The a.c. power supply to the circuit has to be regulated to a reasonable amount for the workability and durability of the circuit components. The power supply regulation circuit is shown in Figure 3. The power supply regulation process is accomplished by following the four stages listed below:

- i. Transformer
- ii. Rectification
- iii. Filtering
- iv. Voltage regulation

#### Transformer

The a.c. supply gives out 220V or above and the supply is stepped down by the transformer to a reasonable amount of 12V which is needed for the operation of the circuit.

#### Rectification

There is the need for the conversion of the a.c. voltage to d.c. voltage. Diodes help in this conversion process. However, in the conversion process the voltage drop across the diode which is greater than 1V is added to the already stepped down 12V and making the total voltage in the rectification to be 13V or greater.

#### Filtering

The capacitor removes or filters the ripples generated and produced alongside the rectification process.

#### Voltage Regulation

Voltage regulator are devices that produce constant d.c. voltage regardless of the variation in the input load. Two voltage regulators are used in this stage. These are:

- i. LM7812 voltage regulator
- ii. LM7805 voltage regulator

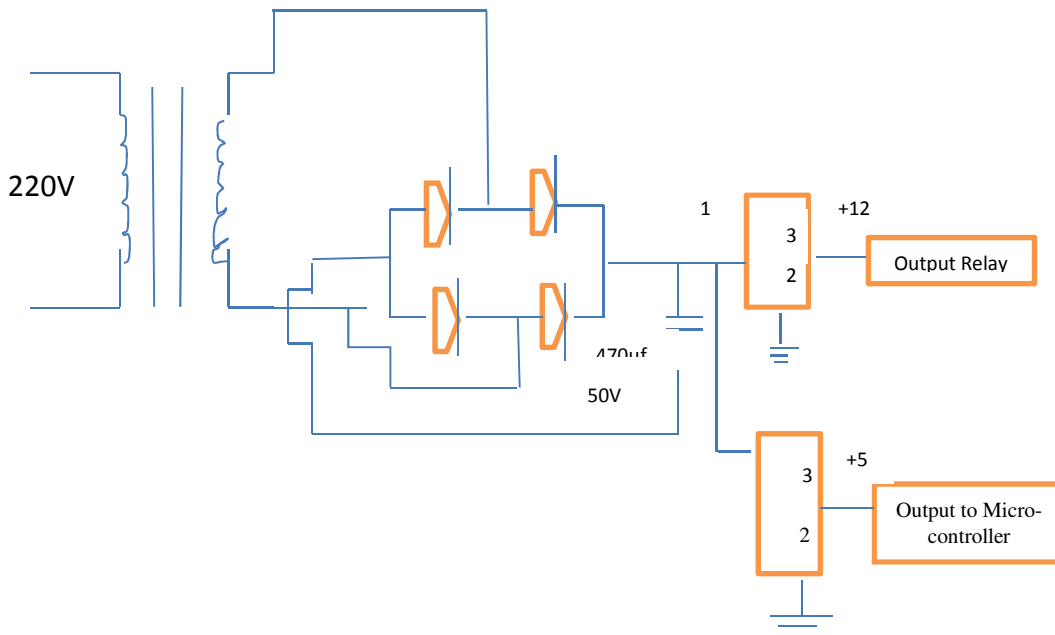

Figure 3: Power supply regulation circuit

### 2.1.2 Main component Circuit Analysis

The USB cable is fed to the DB-9 which is actually a serial connector. This serial connector allows for bi-directional communication between the system and the hardware (I.e it sends signals to and receives signals from the PC.) The DB-9 though stabbed at pin 5 is fed to the MAX232 which is the level converter.

The level converter does and undoes the signal by generating a total of 12V supply and reversing it to 5V d.c. supply. It is fed to the PIC16F876A microcontroller from the level converter. A d.c. voltage of 5V is needed for the operation of the PIC. It processes the signal according to instruction. Attached to the microcontroller is the clock pulse which generates clock frequency for the microcontroller. The clock pulse is the heart of the microcontroller as the microcontroller fails to work in the absence of those clock frequencies.

A d.c voltage of 12V is needed for the operation of the relay. A total of seven relays were used as each relay demands a transistor for amplification. One kilo ohms resistor was also introduced to restrict and oppose

the amount of current that flows to the base of the transistor. The signal is finally executed as the relay opens up to socket to be controlled. The main component circuit analysis is shown in Figure 4.

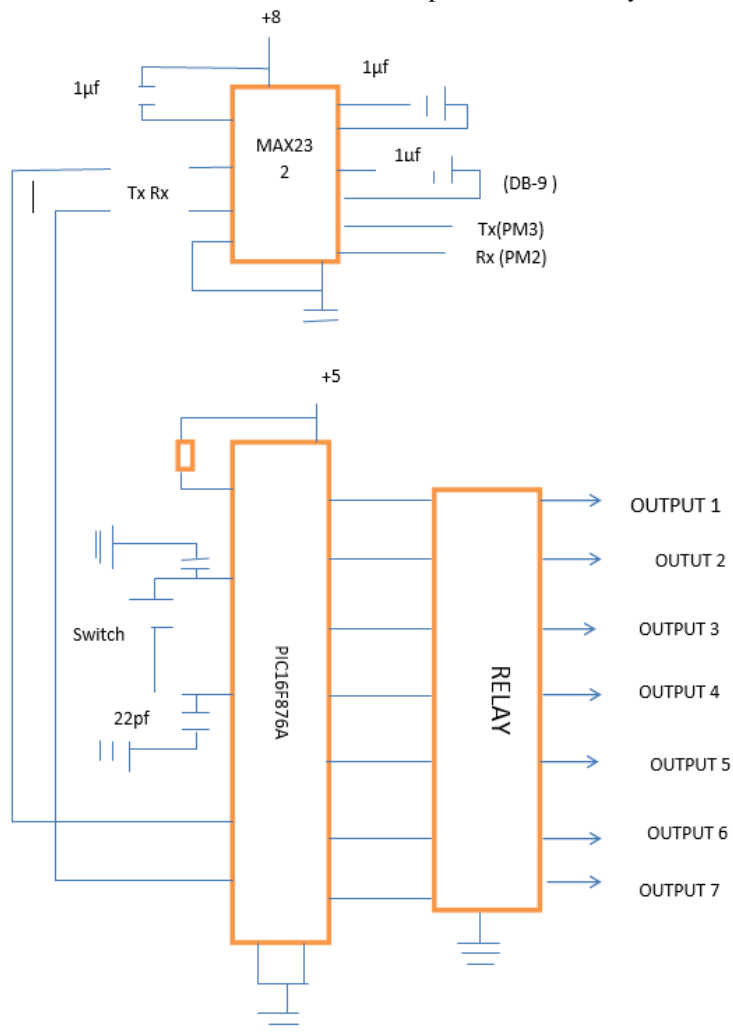

Figure 4: Main component circuit analysis

## 2.2 Software Interface

The layout of the software used for controlling various home appliance is shown in Figure 5. As an experimental basis, the following layouts are present in the software interface:

- i. Seven rooms with their corresponding ON and OFF buttons.
- ii. Selection of communication port
- iii. All ON button
- iv. All OFF button
- v. ROM status interface which consists of check status and clear report.

At first, a port number is set in the Selection Com Port field of the layout to activate connection between computer and microcontroller. If the connection is successful, then it is possible to control the appliances from the computer. Each device can be controlled either as an ON or OFF mode by pressing ON or OFF button on the layout. The “check status” reports the state (ON or OFF) of the electrical control appliances by displaying information that the appliance is ON. The clear report command gets rid of the information reported in the room status interface. Although, only seven rooms have been shown, but any number of devices can be controlled from a computer with a slight modification in the designed system. The software layout interface is shown in Figure 5.

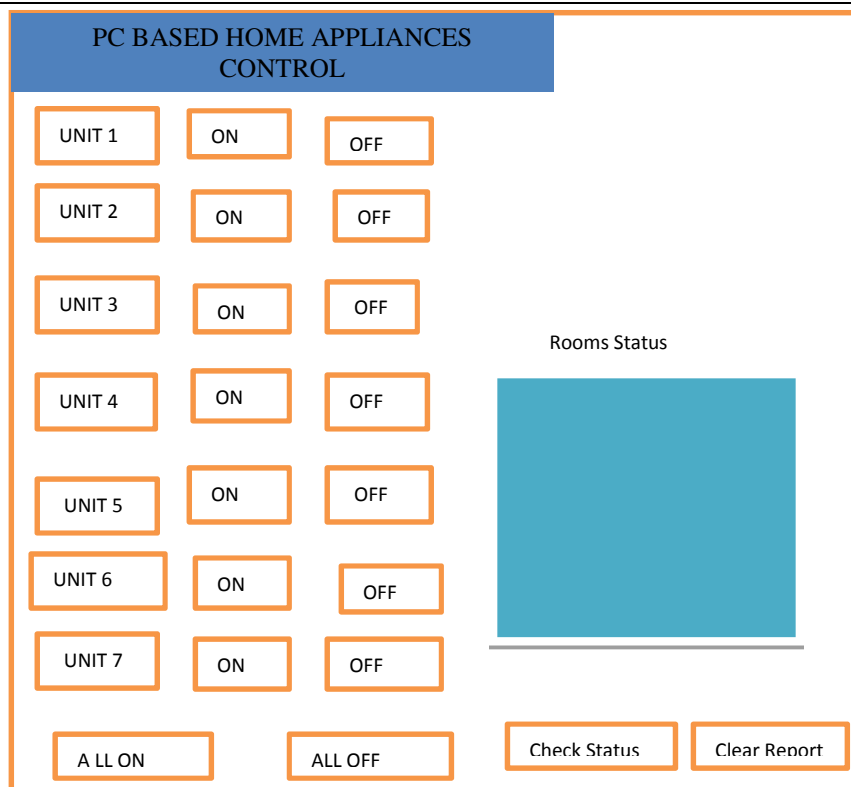

Figure 5: Software Interface layout

### 2.3. PIC-GUI Communication

The hardware uses RS232 converter to communicate with the software. Contained in the RS232 converter is the RS232 library which has RX (receiver) and TX (transmitter) for both transmissions and reception of signals. The software in the other end has serial port library which is one of the controls in c-sharp library. It is thus programmed to enable transmission and reception of signals.

Once the “COM port” is selected in the software, a link is opened up for communication between the hardware and the software which will last for microseconds . Through, there is a propagation delay which allows for execution of commands or instruction before transmission of another signal. For every button clicked in the graphical user interface.The serial port library uses its TX to transmit the signal to the hardware. The signal is received by the hardware via its RX, processed according to instruction and opens up the relay of the required unit and therefore switches ON its socket

The hardware on the reverse end uses its TX to transmit signal (indicating the reception of the sent signal by the program) to the software. The software receives the signal via its RX and thus acknowledges it by displaying the message about the state (ON or OFF) of the required unit on the room status interface. The flow chart showing PIC-GUI communication is shown in Figure 6.

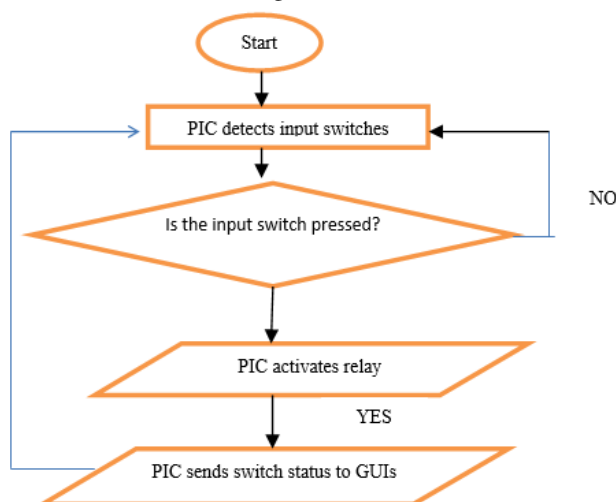

Figure 6: Flow chart showing PIC- GUI communication

### Choice of Programming Language

The application program used in this research paper is C-Sharp.

Reasons for the choice of programming language

- (i) It is very convenient to use (i.e it has improved Graphical User Interface)
- (ii) It has controls that one can pick and drop.
- (iii) It is easier to communicate with the PIC microcontroller.

### Discussion of Results.

Description of Flow Process

Initially, all the switches are in the state. When the ON button is clicked in the software interface to turn ON the desired device, the software converts the ON command into hex code, then sends the value to USB port address. It sends logic 1 (3.5-5V) to the microcontroller through RS232 converter. The microcontroller then sends a 1 to the transistor. It will activate the transistor used to energise the relay. There is an inductor (a wire coil), when energized with an electric pulse, will generate a magnetic field. The second part of the relay is a system of metallic arms, which makes up the physical contact of the switch. When the replay is ON, or an electric pulse is sent to the relay, the swing or switching arm of the relay moves to another contact of the relay. The arm moves as the generated magnetic field pulls the swinging arm towards the inductor (or wire coil), the a.c. circuit is completed and the electrical appliance is turned ON. When the OFF button is clicked to turn off a device, the software converts the OFF command into hex code, then sends the value to USB port address. It sends logic 0 (0-1.5V) to the microcontroller through the RS232 converter. Then the microcontroller sends a 0 to the transistor. It will deactivate the transistor used to energize the relay. The arm of the relay swings back to another position, which makes the path of the current flow open and hence electrical appliance is turned OFF. The terminal input of each appliance is wired across, then sends the value to USB port address. It sends logic 0 (0-1.5V) to the microcontroller through the RS232 converter. Then the microcontroller sends a 0 to the transistor. It will deactivate the transistor used to energize the relay, thus the power to the appliance is switched ON or OFF depending on whether the relay is active or not. The diagram of the flow chart design system is as shown in Figure 7.

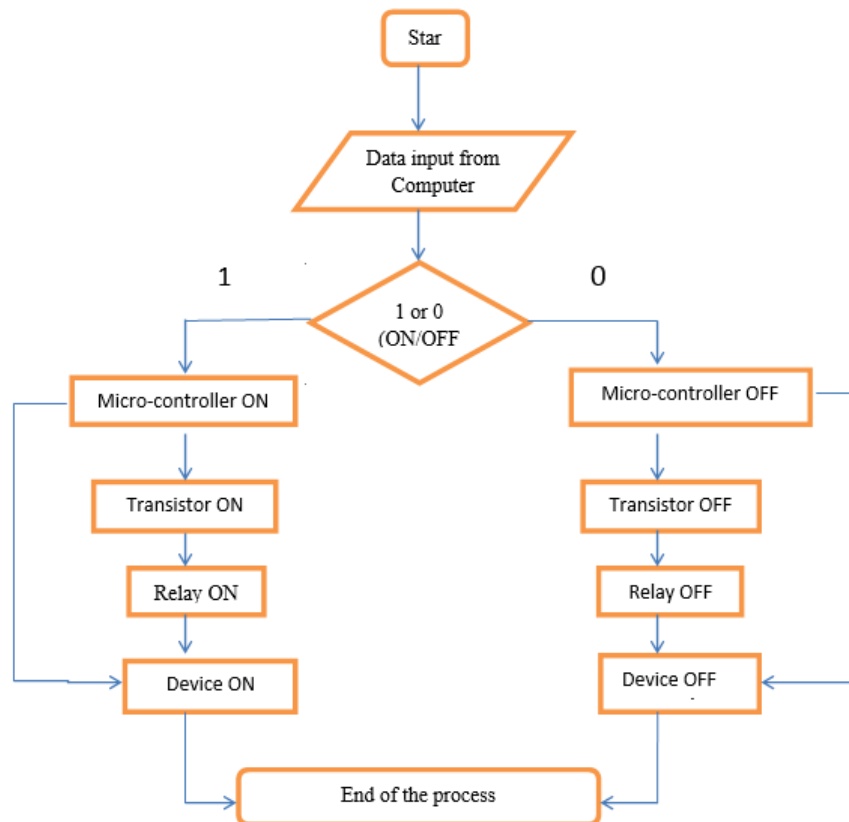

Figure 7: The flow chart of the designed system

### Conclusion

The user's choice is clicked in the developed window application through the PC and signal travels via the USB

cable to the corresponding connection. Based on this command, the required appliance is triggered. It can be used at homes, street light management, hotels, power management, high voltage grid control and in industries.

## REFERENCES

- Al-Ali S.A, AL-Rousan M.T.(2004):“Home Automation System”. IEEE Transactions on Consumer Electronics, Vol.50, No. 2, Pp. 13- 19.
- Anamul H.S.M, Kamruzzaman S.M. (2006): “Microprocessor and Interfacing and Hardware”.Publication, Second Edition, Pp. 33- 41.
- Casimiro A, Kaiser J and Verissimo P.(2004):“An Architecture Framework and Middleware for Control Architecture for Home Automation System in the Internet Era”Proceedings ICRA Cooperating Smart Components, in Proc. Of CF’04 Italy, ACM. Pp. 28-39.
- Coyle L, Neely S, Stevenson G,Sullivan M, Dobson S and Nixon P. (2007): “Sensor Fusion-Based Middleware for Smart Homes”.International Journal of ARM, Vol.8,No. 2, Pp. 53-60
- Dickey N, Banks D and Sukittanon S. (2012): “Home Automation using Cloud Network and Mobile Devices”. Proc. Of IEEE International Conference at Southeast on, Electrotechnical Conference, MELECON 10<sup>th</sup> Mediterranean, Vol. 1,Pp. 298- 301.
- Kim T, Lee H and Chung Y. (2010): “Advanced Universal Remote Controller for Home Automation and Security”. IEEE Transaction on Consumer Electronics, Vol. 56, No. 4, Pp. 2537- 2542.
- Kobatake S, Shirai H, Owada H and Yoshittomi K. (1989): “HBS-Standard-Compatible Home Bus Protocol Controller”. IEEE Trans. On Consumer Electronics, Vol. 35, No. 3, Pp. 605-607.
- Koyuncu B. (1995): “PC Remote Control of Appliances by using Telephone Lines”. IEEE Transaction on Consumer Electronics, Vol. 41.No. 1, Pp. 201- 209.
- Lin P and Broberg H. (2002): “HVAC Application”. IEEE Industry Application Magazine, Pp. 49- 54.
- Neng S L, Li-Chen F abd Chao-Lin W. (2002): “An Integrated, Flexible and Internet- based Networks for Home Automation”. IEEE International Conference on Robotics and Automation, Vol. 2, Pp. 1101- 1106.
- Nichols J and Myers B.A. (2006): “Controlling Home and Office Appliances with Smart Phones”.IEEE Pervasive Computing, Pp. 60- 67.
- Nunes J and Delgado J. (2000): “An Internet Application for Home Automation”. Electrotechnical Conference, MELECON, Vol. 1.Pp. 298- 301.
- Sriskanathan N and Tan K. (2002): “Bluetooth Based Home Automation System”. Journal of Microprocessors and Microsystem, Vol. 26, Pp. 281- 289.
- Swamy N, Kuljaca O and Lewis F. (2002): “Internet-Based Educational Control System Lab Using Net-Meeting”.IEEE Transaction on Education, vol. 45, No. 2, Pp.145- 151.



The IISTE is a pioneer in the Open-Access hosting service and academic event management. The aim of the firm is Accelerating Global Knowledge Sharing.

More information about the firm can be found on the homepage:

<http://www.iiste.org>

### CALL FOR JOURNAL PAPERS

There are more than 30 peer-reviewed academic journals hosted under the hosting platform.

**Prospective authors of journals can find the submission instruction on the following page:** <http://www.iiste.org/journals/> All the journals articles are available online to the readers all over the world without financial, legal, or technical barriers other than those inseparable from gaining access to the internet itself. Paper version of the journals is also available upon request of readers and authors.

### MORE RESOURCES

Book publication information: <http://www.iiste.org/book/>

Academic conference: <http://www.iiste.org/conference/upcoming-conferences-call-for-paper/>

### IISTE Knowledge Sharing Partners

EBSCO, Index Copernicus, Ulrich's Periodicals Directory, JournalTOCS, PKP Open Archives Harvester, Bielefeld Academic Search Engine, Elektronische Zeitschriftenbibliothek EZB, Open J-Gate, OCLC WorldCat, Universe Digital Library, NewJour, Google Scholar

