

# Parametric Study on Reinforced Concrete Beam using ANSYS

Neha S. Badiger (Corresponding author)

Post Graduate student, Department of Civil Engineering, KLE M.S.Sheshgiri College of Engineering and Technology, Belgaum 590 008, India

Plot 893, Sector 6, Vantamuri Colony, Belgaum  
Tel: 91 9845317120 E-mail: neha.badiger@gmail.com

Kiran M. Malipatil

Assistant Professor, Department of Civil Engineering, Dr. M. S. Sheshgiri College of Engineering and Technology, Belgaum 590 008, India

Tel: 9742027444 E-mail: malipatilkiran@gmail.com

*The research is financed by Asian Development Bank. No. 2006-A171 (Sponsoring information)*

## Abstract

Concrete structural components such as beams, columns, walls exist in various buildings and bridges. Understanding the response of these components of structures during loading is crucial for the development of an efficient and safe structure. Recently Finite Element Analysis (FEA) is also used to analyze these structural components. In this paper, four point bending analysis is carried out using reinforced concrete beam. The results of the beam with respect to mesh density, varying depths, use of steel cushions for support and loading points, effect of shear reinforcement on flexure behaviour, impact of tension reinforcement on behaviour of the beam are analyzed and discussed. Finite element software ANSYS 13.0 is used for modeling and analysis by conducting non linear static analysis.

**Keywords:** Material nonlinearity, Finite element analysis, Convergence, Steel cushion, Varying depths, ANSYS.

## 1. Introduction

Experimental analysis is widely carried out to study individual component members and the concrete strength under various loading conditions. This method provides the actual behavior of the structure. But it is time consuming and expensive. Finite element analysis is also used to analyze these structural components. Finite Element Analysis (FEA) is a method used for the evaluation of structures, providing an accurate prediction of the component's response subjected to various structural loads. The use of FEA has been the preferred method to study the behavior of concrete as it is much faster than the experimental method and is cost effective. With the invention of sophisticated numerical tools for analysis like the finite element method (FEM), it has become possible to model the complex behavior of reinforced concrete beams using Finite Element modeling.

Finite element method is a numerical analysis method that divides the structural element into smaller parts and then simulates static loading conditions to evaluate the response of concrete. The use of this technique is increasing because of enormous advancement of engineering and computer knowledge. This method respond well to non linear analysis as each component possesses different stress-strain behavior. The response of each element is expressed in terms of a finite number of degrees of freedom characterized as the value of an unknown function at a set of nodal points. <sup>[5]</sup>

In reality most of the problems are non linear in nature. Hence non linear analysis is an effective tool to obtain exact solution. Non-linear analysis is a method that stimulates the exact behavior of the material to evaluate strength in inelastic range and to identify the potential of high load carrying capacity of the components through redistribution, tensile and shear strength. Nonlinear behavior of reinforced concrete beams is complex due to various parameters. Non-linearity may be geometric or material non-linearity. A structure can have either of the one or both of them. Material non-linearity contains non-linear stress strain relationship of material and hence modulus of elasticity is not a unique value. The geometry of the body is changed during loading in slender members such as columns and also in deformable bodies. Such case, geometric nonlinearity is encountered. <sup>[12]</sup>

In this study, nonlinear finite element analysis is carried out using ANSYS which employs Newton-Raphson method to solve higher order differential equations. Many attempts have been made by the past researchers to predict the behavior using ANSYS. The accuracy and convergence of the solution depends on factors such as mesh density, constitutive properties of concrete, convergence criteria and tolerance values etc. Thus in the present study an attempt is made to perform nonlinear finite element analysis to analyze the reinforced concrete beam.

## 2. Problem considered for the Study

Experimental analysis is widely carried out to study individual component members and the concrete strength under various loading conditions. This method provides the actual behavior of the structure. But it is time

consuming and expensive. Finite element analysis is also used to analyze these structural components. Finite Element Analysis (FEA) is a method used for the evaluation of structures, providing an accurate prediction of the component's response subjected to various structural loads. The use of FEA has been the preferred method to study the behavior of concrete as it is much faster than the experimental method and is cost effective. With the invention of sophisticated numerical tools for analysis like the finite element method (FEM), it has become possible to model the complex behavior of reinforced concrete beams using Finite Element modeling.

### 2.1 Geometry of the Beam

The geometry of the full size beam is 4000mm x 250mm x 450mm. The span between the two supports is 3840mm. Beam is simply supported by providing roller support on both the sides. Two point loads are applied at the midspan of the beam. M30 grade concrete and Fe415 steel is used. The details of the RC beam are as shown in Fig1.

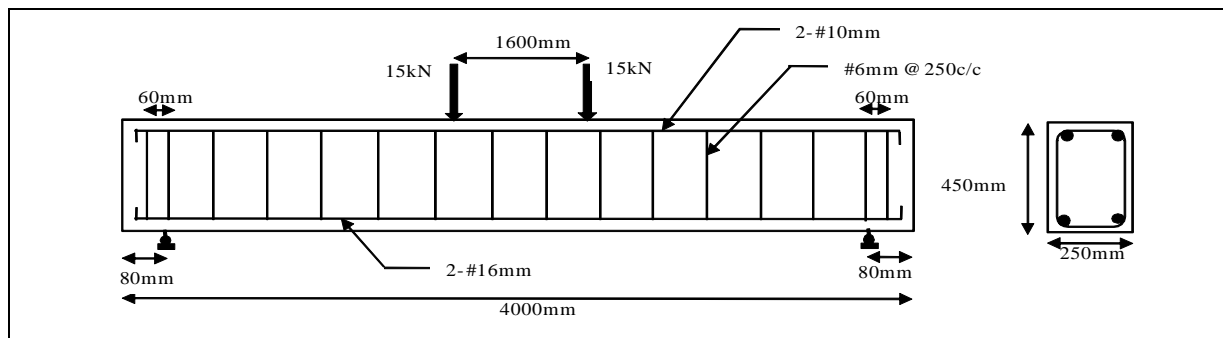

Fig 1: Beam considered for the study

## 3. Material Properties

### 3.1 Steel Reinforcement

Steel reinforcement in RC beam is of grade Fe415. The steel for the finite element models has been assumed to be an elastic-perfectly plastic material and identical in tension and compression. Poisson's ratio of 0.3 has been used for the steel reinforcement in this study. Elastic modulus equal to 200,000 MPa and Poisson's ratio of 0.3 has been used for all the reinforcing bars. Steel plates were provided at support locations and at the loading point in the finite element models (as in the actual beams) to provide a more even stress distribution over the support and loading areas. Same elastic modulus equal to 200,000 MPa and Poisson's ratio of 0.3 were used for the plates. The steel plates were assumed to be linear elastic materials. Tangent modulus of 20N/mm<sup>2</sup> is used for reinforcement to avoid loss of stability upon yielding.<sup>[9]</sup>

**Table: 1 Material property for the Beam Models**

Material Model Number	Element Type	Material Properties		
1	Solid65	<b>Linear Isotropic</b>		
		EX	30000MPa	
		PRXY	0.2	
		<b>Multilinear Isotropic</b>		
			Strain	Stress (MPa)
		Point 1	0.00032	9
		Point 2	0.0006	15.28
		Point 3	0.0009	21.08
		Point 4	0.0012	25.27
		Point 5	0.0015	27.96
Point 6	0.0018	29.42		
Point 7	0.0021	29.96		
Point 8	0.00219	30		
2	Solid185	<b>Linear Isotropic</b>		
		EX	200000MPa	
		PRXY	0.3	
3	Link180	<b>Linear Isotropic</b>		
		EX	200000MPa	
		PRXY	0.3	
		<b>Bilinear Isotropic</b>		
		Yield stress	415MPa	
	Tangent Modulus	20Mpa		

### 3.2 Concrete Properties

Modeling an element for the behavior of concrete is a challenging task. Concrete is a quasi-brittle material and exhibits different behavior in compression and tension. The tensile strength of concrete is typically 8-15% of the compressive strength<sup>[9]</sup>. The modulus of elasticity of concrete is calculated as 27386MPa as per IS 456:2000. Poisson's ratio is 0.2. The shear transfer coefficient for open crack and closed crack are 0.3 and 0.95 respectively. Uniaxial tensile cracking stress is obtained using IS 456:2000 and is 3.834MPa. Concrete material properties are shown in table 1 above.

### 3.3 Compressive Uniaxial stress strain relationship

The ANSYS program requires the uniaxial stress-strain relationship for concrete in compression. The Solid65 element requires linear isotropic and multi-linear isotropic material properties to properly model concrete. The multi-linear isotropic material uses the Von-Mises failure criterion to define the failure of the concrete. [8] Simplified stress strain relationship for concrete in compression is obtained and is shown in Fig 2.

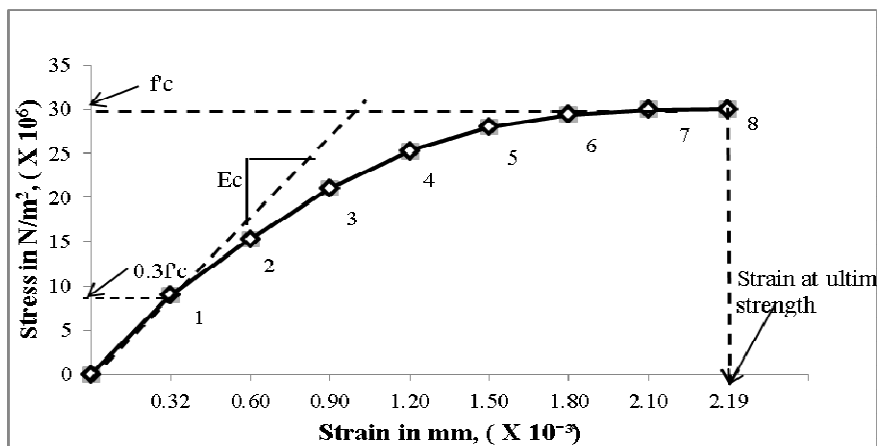
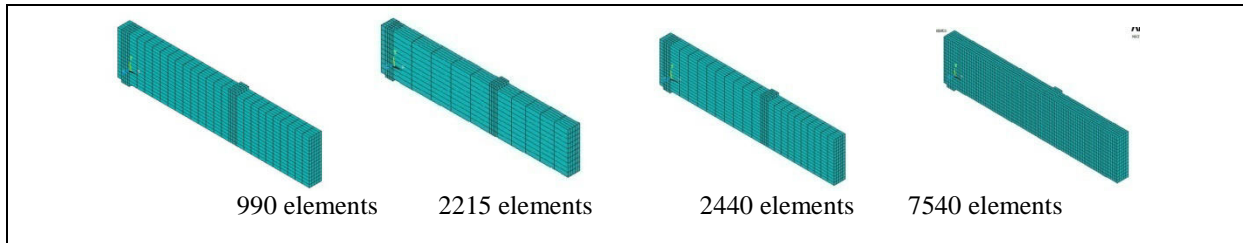

**Fig 2: Simplified uniaxial stress-strain curve for concrete in compression**

### 3.4 Convergence Study

Convergence study is performed using plain concrete beams in a linear analysis. A quarter model of the full plain

concrete beam is considered for the study without steel reinforcement to determine the appropriate mesh density. Ten plain concrete beams of dimensions 2000mmX450mmX125mm and same material properties are modeled in Ansys 13 with increasing number of elements 355, 990, 1240, 1840, 1940, 2215, 2440, 4490, 5400 and 7540 using Solid65 concrete elements. Beam models used for study are shown in figure 3 below. A plot of load versus midspan deflection is done and it is observed that the deflection remains constant from 1840 elements to 7540 elements. The deflection is constant irrespective of the increase in elements. The observed deflection is 0.722mm. So the finite element model consisting of 4490 number of Solid 65 concrete elements is used for this entire study. Convergence plot is done and shown in figure 4 below.



**Fig 3: Beam models used for convergence Study**

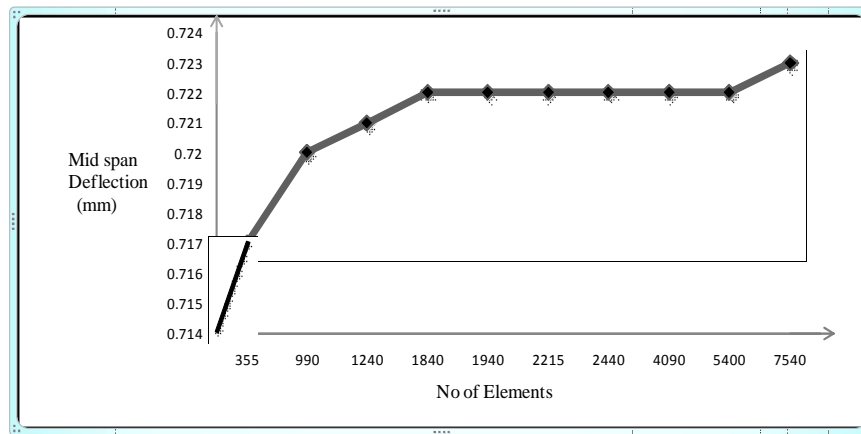

**Fig 4: Results of the convergence study**

#### 4. Elements used for Modeling

Concrete beam is modeled using eight node Solid65 element which has three degrees of freedom at each node. For modeling steel reinforcement, Link180 spar element with three degrees of freedom at each node is used. Supports and loading points are modeled using eight noded Solid180 elements.

##### 4.1 Modeling of Reinforced Concrete Beam

The beam, plates and the support are modeled as volumes. Since a quarter of the beam is modeled, the beam is 2000mm long having a cross section of 125mm x 450mm. The dimensions of the concrete volume are as shown in the table 2.

**Table: 2 Dimensions for Concrete, Steel Plate, and Steel Support Volumes**

ANSYS	Concrete (mm)		Steel Plate mm)		Steel Support (mm)	
X1,X2 X-coordinates	0	2000	1160	1240	40	120
Y1,Y2 Y-coordinates	0	450	450	475	0	-25
Z1,Z2 Z-coordinates	0	125	0	125	0	125

##### 4.2 Loading and Boundary Condition

Boundary conditions are required to get a proper solution for the model. Because a quarter of the entire beam is used for the model, planes of symmetry are required at the internal faces. The symmetric boundary condition is set first. The beam model being used is symmetric about two planes i.e. X and Z plane. [6] A quarter of the full beam was used for modeling by taking advantage of the symmetry of the beam and loadings. Planes of symmetry were required at the internal faces. At a plane of symmetry, the displacement in the direction perpendicular to that plane was held at zero. The load P applied at the steel plate is applied across the entire center line nodes of the plate. The force applied at each node on the plate is one twelfth of the actual load applied.

## 5. Analysis Type

A nonlinear structural analysis is performed to study the nonlinear material behavior of concrete beam. ANSYS13.0 employs “Newton-Raphson” method to solve nonlinear problems. In order to predict the nonlinear material behavior, the load is sub divided into series of load increments. The load increment can be applied over several load steps. The number of load steps required for the study is given and the time for each load step is mentioned. During the initiation of concrete crack, the steel yielding stage and at the ultimate stage where large numbers of cracks occurs, the loads are applied gradually with smaller load increments. Failure of the model is identified where the solution fails to converge even with very low load increment.

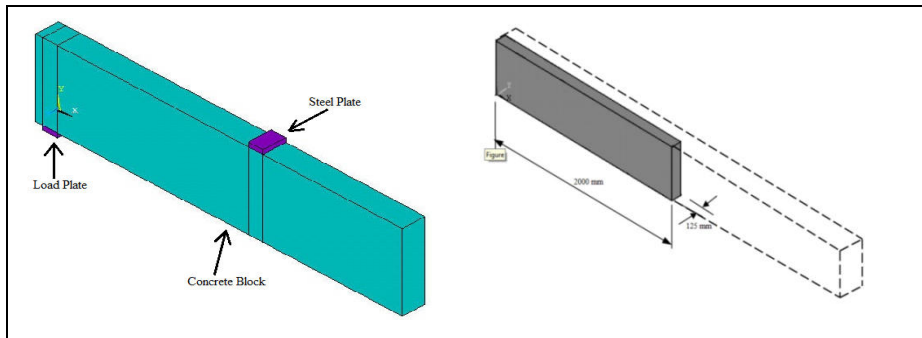
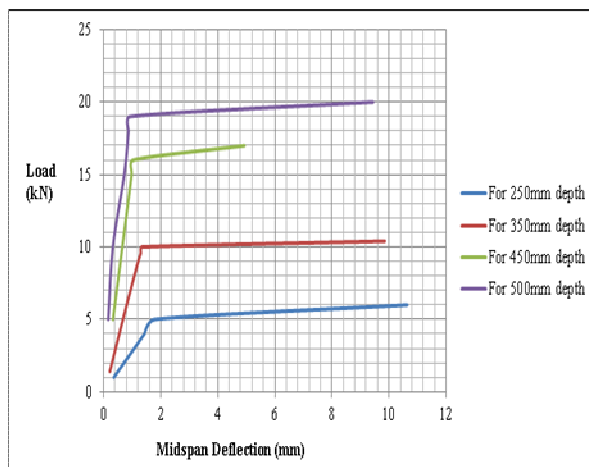

**Fig 5: Volumes Created in ANSYS Quarter beam model**

## 6. Results and Discussions

### 6.1 Comparison of the Load-Deflection Curve for different depths

A parametric study is performed on the depth of the beam to study the behavior of the beam. Load deflection curve for different depths of beam are done and the load at first crack is obtained. The depths adopted are 250mm, 350mm, 450mm and 500mm.

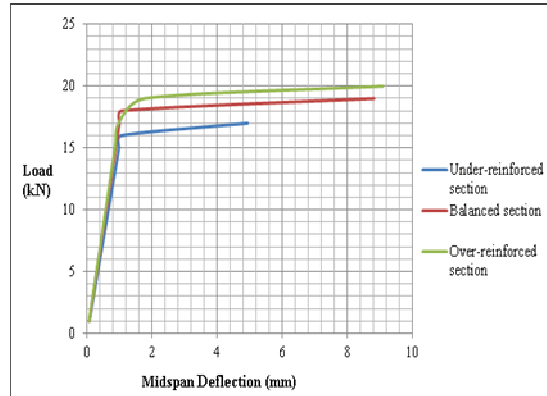

**Fig 6: Comparison of Load-Deflection curves for all the depths**

Comparison of Load-Deflection curves for all the depths are shown in fig 6 above. It is observed that as the depth of the beam increases, fracture instability is affected. Load carrying capacity of the beam increases with increasing depth but the deflection also increases. For 500mm depth, though the load at first crack is 20kN, the deflection is more. It is about 9.439mm. Also for beam of 250mm depth, load at first crack is early at 6kN and the deflection is also too high about 10.635mm. For beam of 350mm depth, load at first crack is about 10.4kN which is moderate but the deflection is high again. For beam of 450mm depth, load at first crack is about 17kN which is moderate and deflection is also not too high or too low. It is about 4.93mm.

### 6.2 Comparison of Under, Balanced and Over Reinforced Beams

Flexural behavior of reinforced concrete beams is studied using variation in percentage of steel reinforcement. Three percentages were adopted. They are 0.38% (under reinforced), 1.47% (balanced) and 1.87% (over reinforced). Load deflection graph for all the three percentages are done and the behavior of the beam is studied.

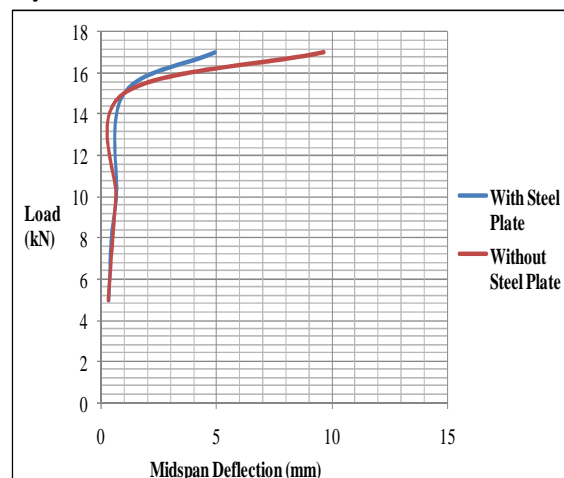

**Fig 7: Comparison of Load-Deflection curves for under, balanced and over reinforced sections**

Comparison of load-deflection curves for under; balanced and over reinforced sections are shown in fig 7 above. It is observed that the behavior of the beam in uncracked elastic region is almost the same for various percentage of steel and mainly depends on the grade of concrete. It is seen that for higher values of reinforcement percentage, the transition of the beam from elastic to cracked section is smooth due to contribution of moment of inertia by the steel in place of the loss of moment of inertia due to cracking. The initial cracking behavior of the beam is not much influenced by the reinforcement percentage. But it has more impact in the post cracking stage of the beam. Thus the ultimate capacity of the beam can be varied by varying the reinforcement percentage.

### 6.3 Effect of Steel Cushion at Support and Loading Point

SOLID185 element bonded with SOLID65 element is used at the support and the loading points, to overcome the stress concentration problems. The support conditions and the loading are applied at the nodes of the Solid185 element and the effect of steel cushion on the behavior of RC beams is studied. It is observed that the behavior of the beams practically remains the same.



**Fig 8: Comparison of Load-Deflection curves for beam with and without steel plate**

A comparison of load-deflection curves for beam with and without steel cushion is done and is shown in the fig 8 above. It is observed that the responses of the analysis in both the cases are same up to yielding. It is seen that the load at first crack varied marginally. For the beam without steel plate, load at first crack is 16.2kN and deflection about 9.66mm and for the beam with steel plate, load at first crack is 17kN and deflection is 4.93mm. Thus the load at first crack is marginally more for beam with steel plate. Also the deflection for beam without steel plate is more than the beams with the steel plate.

## 7. Conclusions

In this study, the behavior of reinforced concrete beam is analyzed using finite element method. A control beam is analyzed using a specific set of control data and is then compared to the succeeding models by changing the parameters. The parameters used to complete this study are varying depths, steel percentage, steel cushion and shear reinforcement. After compiling and analyzing the results from each test, the following conclusions can be

made:

1. Reinforced concrete beam can be modeled and analyzed using ANSYS 13.0 software and obtain accurate results.
2. Deflections and stresses at the centerline along with initial and progressive cracking of the finite element model compare well with the manual calculations obtained for a reinforced concrete beam.
3. As the depths of the beams are increased, the load carrying capacity increases but the deflection. For smaller depths, load carrying capacity is low and deflection is also very large.
4. It is observed that by varying the tension steel, the initial cracking behavior is not affected. But it has more impact in the post cracking stage of the beam. The ultimate capacity of beam can be varied by varying the steel percentage.
5. By removing steel plate at support and loading point, stress concentration takes place. Also the beam without steel plate shows more cracks than the beam with steel plate. Hence for more accurate analysis, steel cushion has to be included in modeling.

## References

1. E.Chandrasekaran and R.Santhakumar, "Analysis of Retrofitted Reinforced Concrete Shear Beams using Carbon Fiber Composites" Electronic Journal of Structural Engineering, April 2004.
2. Hamid Saadatmanish, Mohammad R Ehsani and Tom Norris, "Shear and Flexural Strengthening of RC beams with Carbon Fiber Sheets" Journal of Structural Engineering, July 1997.
3. P. Fanning, "Nonlinear Models of Reinforced and Post-tensioned Concrete Beams", Electronic Journal of Structural Engineering, February 2001.
4. Al-Tantawy, F.A. Fathelbab and M.S. Ramadan, "Finite Element Modeling of Strengthened Simple Beams using FRP Techniques: A parametric Study", International journal for the Science and Engineering of Concrete and Building materials, June 2011.
5. A.Bashir, K. Ahmad, H.U. Khan, M.N. Rafique and S. Karam, "Identification of Shear Cracks in Reinforced Beams Using Finite Element Method", Pakistan Journal of Science, Vol. 66, No. 1, March 2014.
6. Anthony J. Wolanski, B.S, "Flexural Behavior of Reinforced and Prestressed Concrete Beams Using Finite Element Analysis", A Thesis submitted to the Faculty of the Graduate School, Marquette University, May, 2004
7. A.Khennane, L. Dahmani and S. Kac, "Crack Identification in Reinforced Concrete Beams Using Ansys Software", Strength of Materials, Vol. 42, No. 2, 2010
8. I.Saifullah, M.A. Hossain, S.M.K.Uddin, M.R.A. Khan and M.A. Amin, "Nonlinear Analysis of RC Beam for Different Shear Reinforcement Patterns by Finite Element Analysis", International Journal of Civil & Environmental Engineering, Vol:11 No: 01, February 2011.
9. Damian Kachlakev and Thomas Miller, "Finite Element Modeling of Reinforced Concrete Structures Strengthened with FRP Laminates", for Oregon Department of Transportation Research Salem, and Federal Highway Administration Washington, May 2001.
10. Kothandaraman.S, Vasudevan. G, "Parametric Study On Nonlinear Finite Element Analysis On Flexural Behaviour Of RC Beams Using Ansys", International Journal Of Civil And Structural Engineering Volume 2, No 1, 2011.
11. Miguel Patricio, Robert M.M. Mattheij, "Crack Propagation Analysis", Scribd
12. A.KANCHANADEVI and C. UMARANI, "Non-Linear Finite Element Analysis for Assessment of Bridges", International Journal of Earth Science and Engineering, Vol. 02, No. 06, December.

The IISTE is a pioneer in the Open-Access hosting service and academic event management. The aim of the firm is Accelerating Global Knowledge Sharing.

More information about the firm can be found on the homepage:  
<http://www.iiste.org>

## CALL FOR JOURNAL PAPERS

There are more than 30 peer-reviewed academic journals hosted under the hosting platform.

**Prospective authors of journals can find the submission instruction on the following page:** <http://www.iiste.org/journals/> All the journals articles are available online to the readers all over the world without financial, legal, or technical barriers other than those inseparable from gaining access to the internet itself. Paper version of the journals is also available upon request of readers and authors.

## MORE RESOURCES

Book publication information: <http://www.iiste.org/book/>

## IISTE Knowledge Sharing Partners

EBSCO, Index Copernicus, Ulrich's Periodicals Directory, JournalTOCS, PKP Open Archives Harvester, Bielefeld Academic Search Engine, Elektronische Zeitschriftenbibliothek EZB, Open J-Gate, OCLC WorldCat, Universe Digital Library, NewJour, Google Scholar

