

Decision Analysis for Jack-up Foundation Embedment in Shallow Offshore Nigeria

Abam T.K.S¹ Kiri N²

1.Geotechnics Division, Institute of Geosciences and Space Technology (IGST)

Rivers State University of Science and Technology, P.M.B. 5080, PortHarcourt, Nigeria

2.Groundscan Services Nigeria Limited, 1 Brown Abiye Avenue, Trans-Amadi, P.O.Box 9528, PortHarcourt, Nigeria

Abstract

Drilling operations in offshore waters less than 120m is commonly carried out on Jack-up rigs. The installation of spudcan footing of these rigs is both delicate and significantly risky, with potential prospects of litigation, where foundation analysis decisions are defective. Case studies of spudcan soil penetration analysis for different soil conditions and stratigraphic configurations are presented along with the decision analysis for spudcan foundation embedment. The study identifies significant natural variability in soil composition, reflecting the complex hydrodynamics governing sedimentation in the Niger Delta. It confirms the working load and spudcan geometry as crucial factors in the determination of risks free embedment depths.

Introduction

Most of the world's offshore drilling in water depths up to 120m is performed using self-elevating "jack-up" mobile units. Traditionally foundations of independent-leg jack-up platforms approximate large inverted cones commonly known as 'spudcans' (fig. 1). The effort required for the installation of spudcan footing depends on the soil type and conditions. For example, the installation of spudcan footing in sand deposit requires less effort compared to other soil profiles. This is because the typical maximum installation load of the spudcan which ranges from 48 to 100MN could be achieved at a relatively shallow penetration depth in a granular soil bed. In scenerios where sand overlies clay, the installation of spudcans is often subjected to a potential punch-through hazard. This occurs when the applied load exceeds the maximum bearing resistance of the upper sand layer causing the spudcan to plunge into the underlying clay. Such failures often result in a huge financial loss.

According to Kee and Ims (1984), the predicted spudcan penetration responses obtained using existing design methods often deviate from the field performance, because of neglect of several important factors including the geometric distortions of the soil layers during substantial penetration, soil hardening/softening and remoulding and the initial stress conditions with penetration increase. This highlights the necessity for a reappraisal of existing methods.

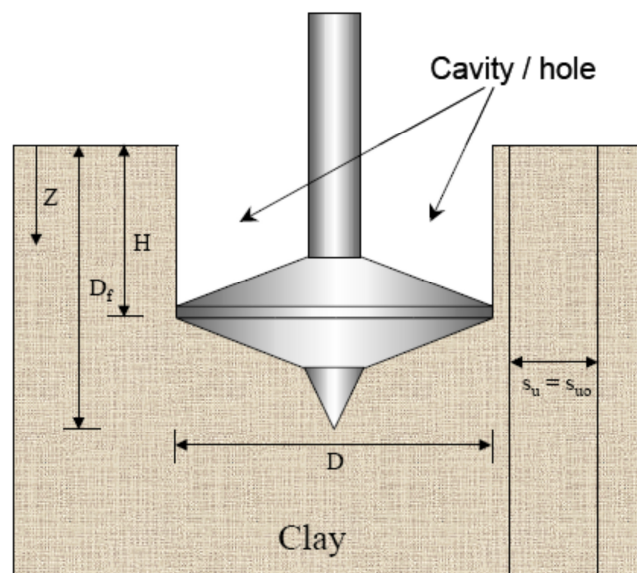

Fig. (1) Typical shape of a spudcan (after Hossain et al 2003)

Conventionally, spudcan installation involves a preloading process to proof test the foundation stability. The spudcan foundation reaction during the preloading stage is assessed to be only the vertical force components. This is because, preloading following self weight installation occurs in calm weather in which the environmental forces are deemed insignificant. For this spudcan bearing capacity assessment, conventional ultimate vertical bearing capacity formulas proposed by Hansen (1970) are recommended by SNAME (2002).

Fundamentally, the bearing capacity equations for homogeneous soil conditions and modified procedures for layered soil conditions are normally used for soil penetration prediction. However, Craig and Chua, (1990) observed that since offshore foundations are subject to combined vertical and horizontal moments, the predicted ultimate limit states using the conventional bearing capacity theory would produce conservative results. This paper presents a decision analysis for the embedment of spudcan in different soil stratigraphic scenarios, at preselected and coded locations in the Niger Delta.

Method of Analysis

Engineering analyses were performed using design soil parameters interpreted from the results of the *in situ* CPTs and from the results of boring and laboratory testing at various locations in the shallow continental shelf area of the Niger Delta.

Design Soil Profiles

The design soil profile adopted in the spudcan penetration analyses extended to the maximum depth of the boreholes which varied from 30m to 105m. The key input variables for non-cohesive soils are the submerged unit weight (γ') and the internal angle of friction (ϕ). The key input variables for cohesive soils are the submerged unit weight (γ') and the undrained shear strength (S_u). In the presence of silt materials or interbedded layers of sand and clay which may behave either drained or undrained during initial loading, these are assigned an internal friction angle and shear strength. Analyses were then performed using both strength parameters and the results presented for the most conservative approach.

The Spudcan Geometry of the 'Trident IV' with three independent legs, each consisting of a structural truss connected to a spudcan footing has been used. The preload per leg is 48.40MN. Backflow of soil on top of the spudcan during penetration has been modeled up to a limit of 100%. The scenarios of layered soil profiles considered are in two main situations: soft soil over stiff soil, stiff soil over soft soil or a combination of more than two layers alternating stiff and soft soil. In the first case the mechanism involved is generally the lateral squeezing of the confined weaker layer. In the second case the punch through potential involved is associated with sudden rapid increase in spudcan penetration when the bearing capacity is dominated by the weaker layer.

The method of analysis was based on the guidelines of the Society of Naval Architects and Marine Engineers (SNAME) Technical and Research Bulletin 5-5A, Recommended Practice for Site. This method computes the vertical bearing capacity of the footing at various depths below seabed using closed form bearing capacity solutions for each soil layer. Additionally, specific failure mechanisms are analyzed for certain combinations of layered soils; e.g. softer cohesive layer overlying harder cohesive layer, punch through from a harder cohesive layer to a softer cohesive layer, punch through from a non-cohesive layer overlying a non-cohesive layer, etc.

Where back flow of material on top of the spudcan is liable to occur, the vertical bearing capacity of the footing is reduced by an amount equal to the weight of back flow soil. As the basis of all analyses the bearing capacity for each soil layer is computed as set out in the sections below.

Non-cohesive Soils

In non-cohesive soils the foundation capacity is calculated from the following expression:

$$F_v = (0.5 \cdot \gamma' \cdot B \cdot N_{\gamma} \cdot S_{\gamma} \cdot d_{\gamma} + \sigma_{vo}' \cdot N_q \cdot S_q \cdot d_q) \cdot A + \gamma' \cdot V' \quad \text{-----(1)}$$

where:

- F_v = Vertical foundation capacity
- γ' = Submerged unit weight of soil
- B = Effective spudcan diameter
- N_{γ}, N_q = Bearing capacity factors
- s_{γ}, s_q = Bearing capacity shape factors
- d_{γ}, d_q = Bearing capacity depth factors
- σ_{vo}' = In situ vertical effective stress
- A = Spudcan effective bearing area
- V' = Spudcan volume below footing depth

Cohesive Soils

In cohesive soils the foundation capacity is calculated from the following expression:

$$F_v = (S_{uo} \cdot N_c + \sigma_{vo}') \cdot A + \gamma' \cdot V' \quad \text{-----(2)}$$

where:

- F_v = Vertical foundation capacity
- S_{uo} = Undrained shear strength at the footing depth
- N_c = Bearing capacity factor for cohesive soil

Results and Discussions

The results from the above analyses are presented in the combined form of lithology and leg load versus spudcan tip penetration for various shallow offshore locations.

Adanga

Results of Spudcan Penetration analyses for Adanga is presented in (Fig. 2).

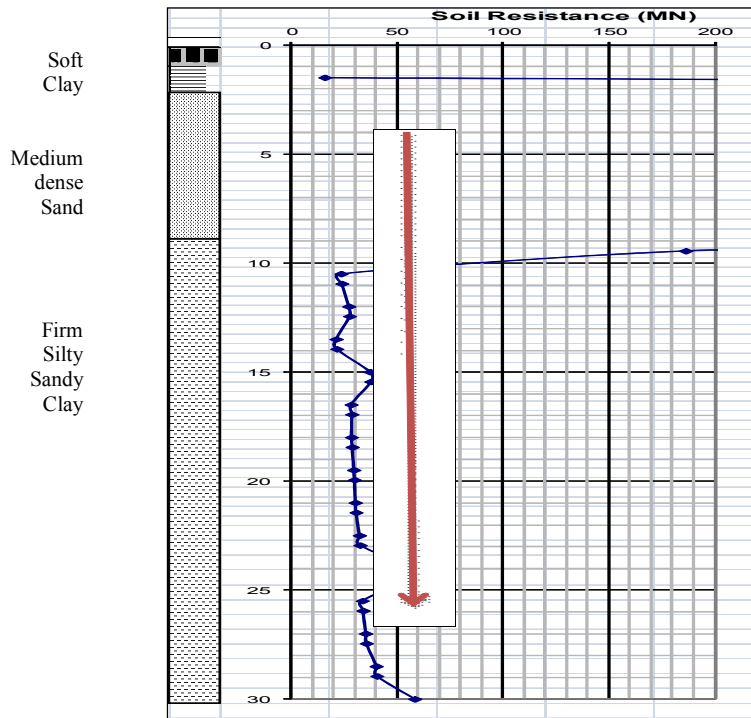

Fig.2: Soil Penetration Resistance Depth Profile for Adanga

We have a scenario of a competent sandy layer, overlying a soft and weak silty clay sediments. The competent upper layer is 7.5m thick and consists of medium dense sand. The stress increment beneath a spudcan leg, induced by the fully loaded jack-up was assessed using the relationship (Bowles 1996):

$$\Delta p = q_0 \left\{ 1 - \frac{1}{\left[1 + \frac{(B)^2}{(2Z)^2} \right]^{3/2}} \right\} \dots\dots\dots 3$$

where, q_0 = load per leg of jack-up
 B = diameter of spudcan
 Z = depth of embedment

On the basis of equation (3), using a stress distribution shown in Fig. 3, the variation of p/q_0 for uniformly loaded flexible circular area at the base of the sandy layer was calculated to be 0.508. This implies that the fraction of the load intensity transmitted to the underlying soft layer is 0.508 of 49MN, which translates 24.89MN.

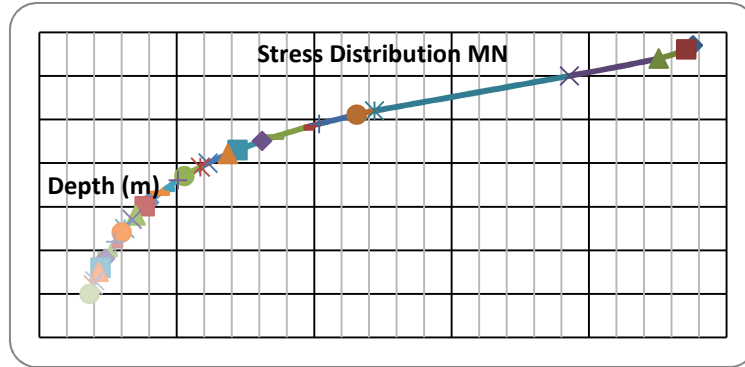

Fig. (3): Stress distribution with depth

The minimum soil ultimate bearing capacity required to prevent shear failure at the top of the underlying clay sediment would therefore be $24.89\text{MN} / 147\text{m}^2 = 169 \text{KN/m}^2$

By extension, the following relationship for bearing capacity can apply:

$$6C_u + \gamma z = 169.$$

Consequently, the minimum undrained shear strength that the underlying clay soil should possess to avoid shear failure can be estimated by:

$$\begin{aligned} C_u &= \left\{ \frac{169 - \gamma z}{6} \right\} \\ &= \left\{ \frac{169 - 4.5 \times 9}{6} \right\} \\ &= 21.48\text{KN/m}^2 \end{aligned}$$

The strength within the underlying soft clay sediments was within this range and only occasionally marginally higher than 21.48KN/m^2 , it is reasonable to expect that the risk of punch through failure exist.

Similar soil profiles were encountered at Kegba and Mefa (Figs. 4 and 5) except that the depth to and thickness of the competent sand layer varied.

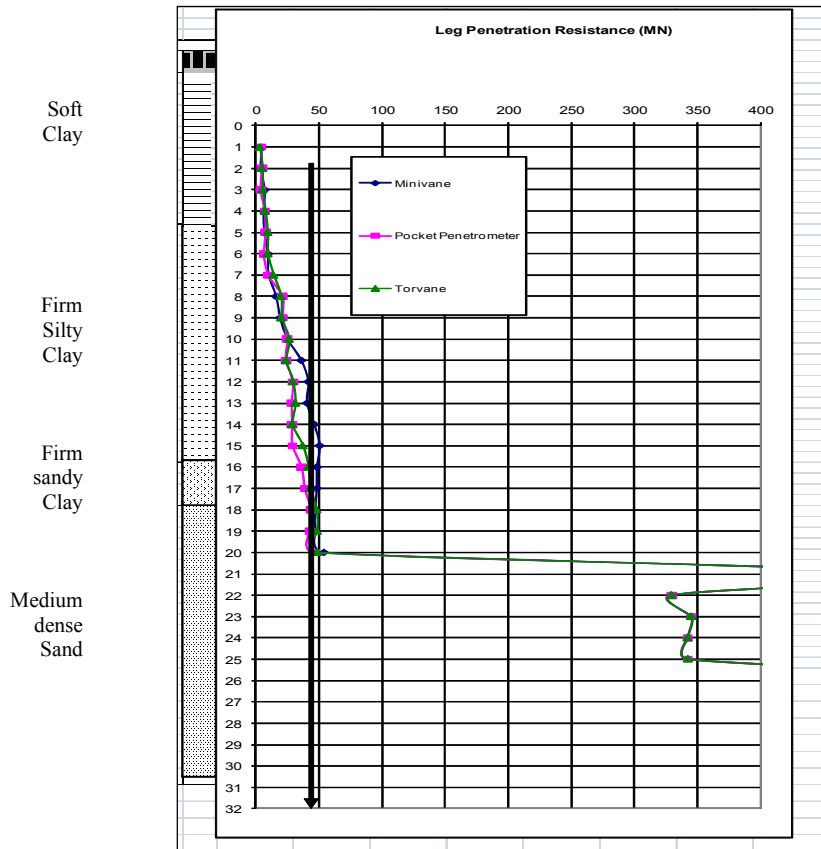

Fig.4: Soil Penetration Resistance Depth Profile for Kegba

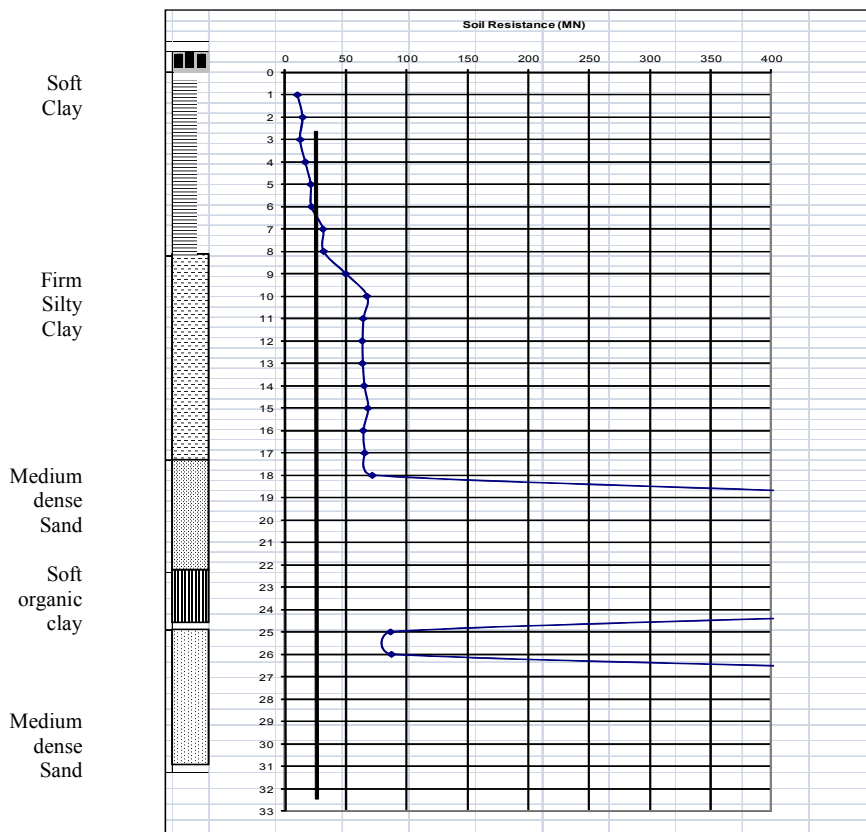

Fig.5: Soil Penetration Resistance Depth Profile for Mefa

At ESSAR, we have a scenario of a fairly uniform soil condition (Fig. 6), consisting of a normally consolidated soft to firm silty clay sediments. Analysis of oedometric results indicated some measure of settlement (Fig. 7). Combining these results, it was recommended that the spudcan penetration legs be driven to 30m below the sea floor. At this depth the undrained strength within the underlying clay sediments is higher than that required to maintain stability. It is therefore reasonable to expect that punch through failure is unlikely, although the risk may not be eliminated.

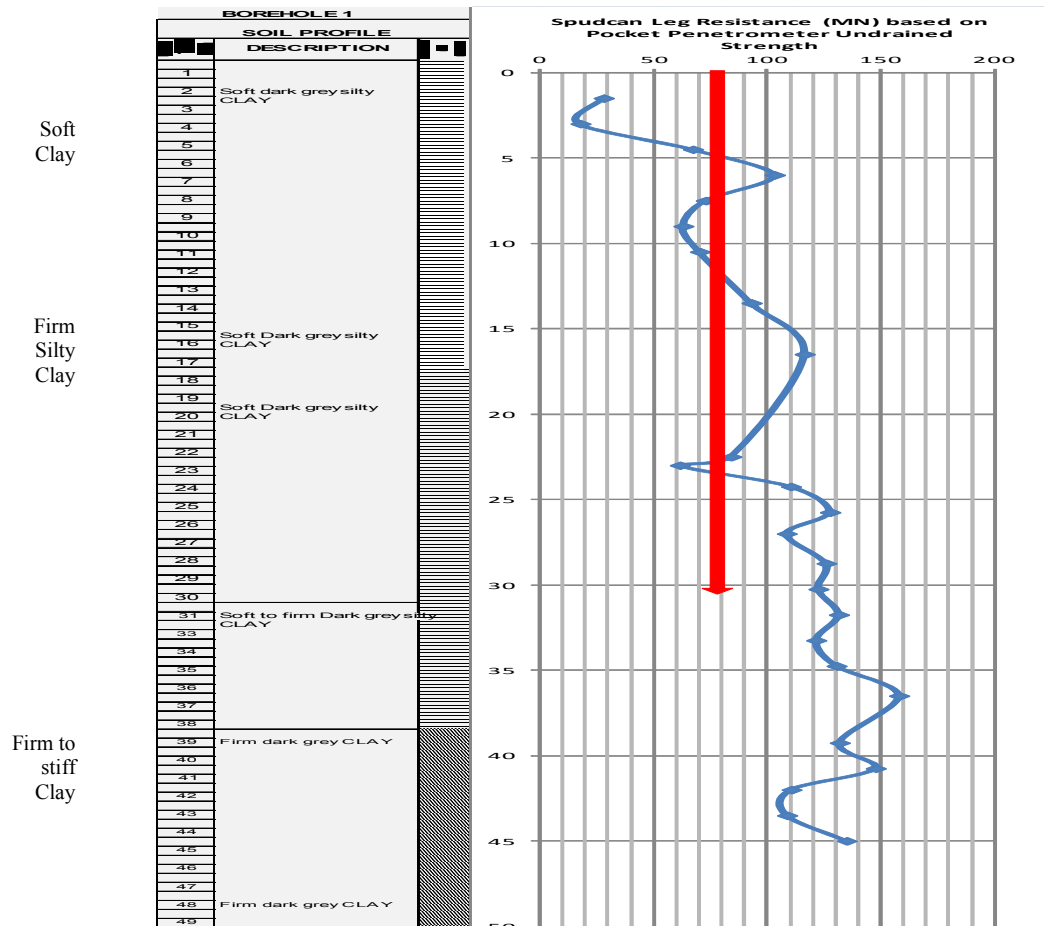

Fig.6: Soil Penetration Resistance Depth Profile for Essar

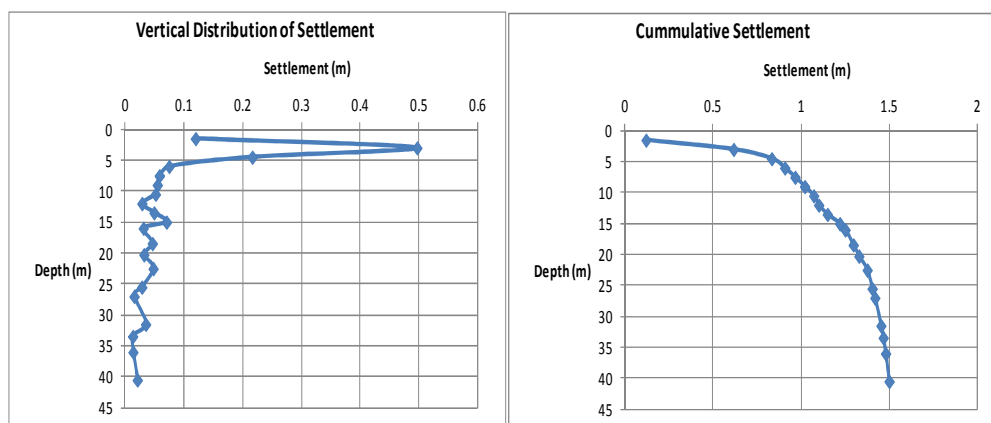

Fig.7: Settlement Distribution at Essar site

The soil profile at Ebok and Akepo are similar to the profile in ESSAR. In these cases, the soil resistance to penetration as determined from different undrained strength measurements also increased monotonically (Figs. 8 and 9) the spudcan embedment were extended to 32m and 24m respectively, at which depth the risks of failure

was considered of little significance.

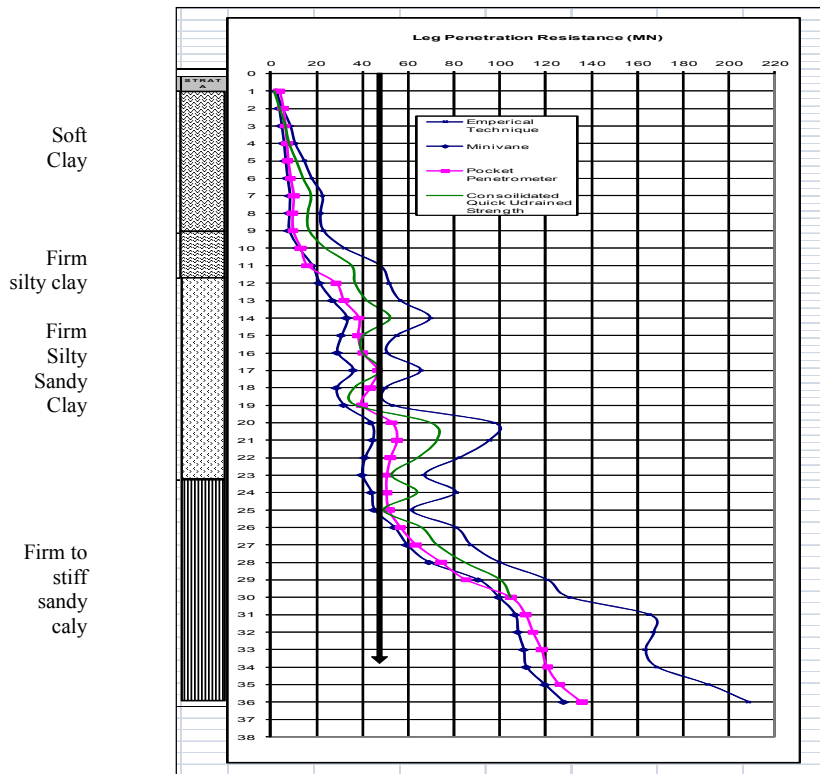

Fig. 8: Soil Penetration Resistance Depth Profile for Ebok

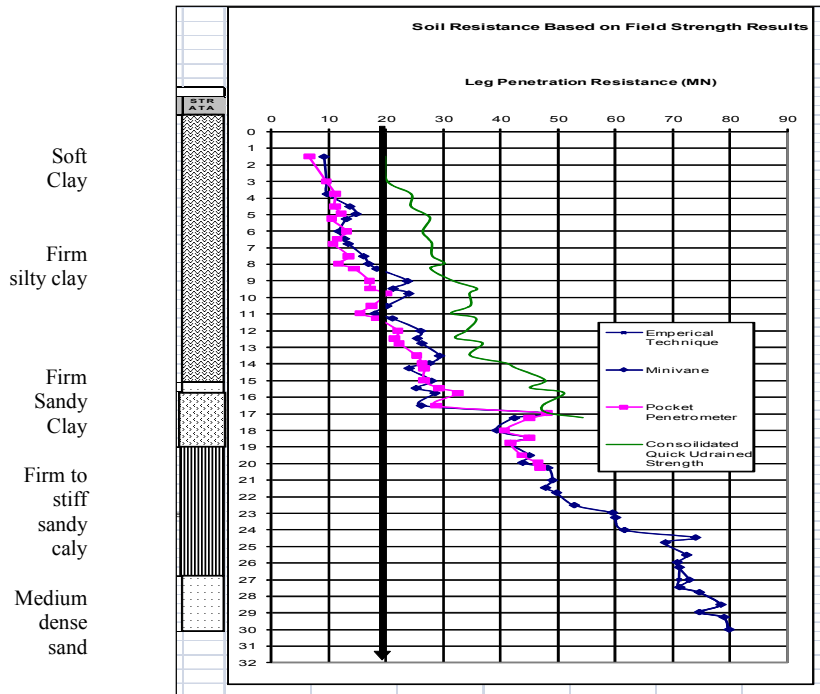

Fig.9: Soil Penetration Resistance Depth Profile for Akepo

At Inagha and Malu we have fairly similar soil profile scenario in which an alternating sequence of clay/ sand/ clay/ sand occurs but with varying thicknesses (Figs. 10 and 11). At INAGHA location, the upper layer, consisting of a very soft silty clay to firm sandy clay sediments (0 – 10m), overlies a competent medium dense to very dense silty fine sand layer (10- 15.5m) that is only roughly 5m thick. This layer exhibited good prospect for the support of a fully loaded Jackup, however, the thinness of the sandy layer presented significant risks for

Punch-through failure as a 1.5m thick stiff clay occurs from 16m depth to 17.5m below mudline. This clay layer which was described as stiff with undrained cohesion of 50kN/m^2 , possessing a soil penetration resistance of 77MN may appear adequate, but nevertheless presents punch-through risks within the predominantly sand formation. Below this clay layer, the Soil Penetration Resistance increases monotonically, offering the best depth horizon for embedment of the Spudcan. The spudcan penetration legs were therefore driven beyond these horizons and perched at about 19m below the sea floor.

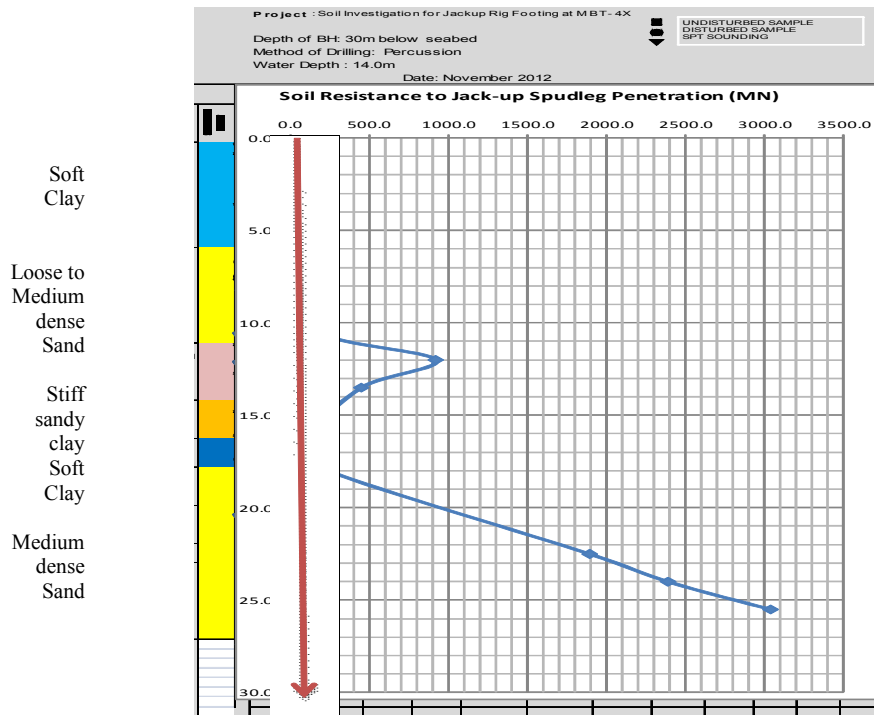

Fig. 10: Soil Penetration Resistance Depth Profile for Inagha

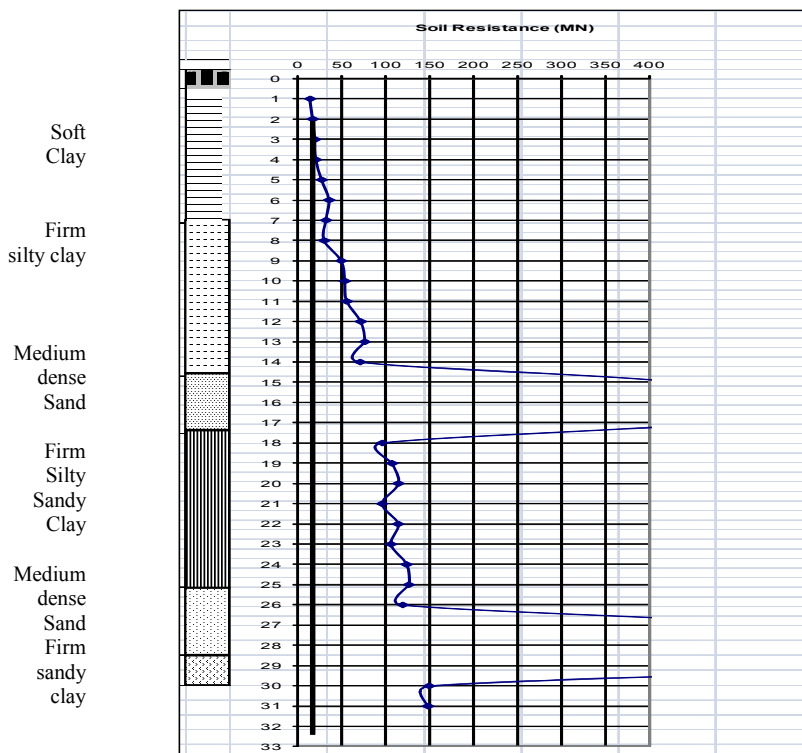

Fig. 11: Soil Penetration Resistance Depth Profile for Malu

Otuo North location presented a scenario of a competent upper layer, overlying a very soft and weak clay sediments (Fig. 12). The competent upper layer is 12m thick and consists of sand. As with Adanga, the stress increment beneath a spudcan leg, induced by the fully loaded jack-up was evaluated using equation 3:

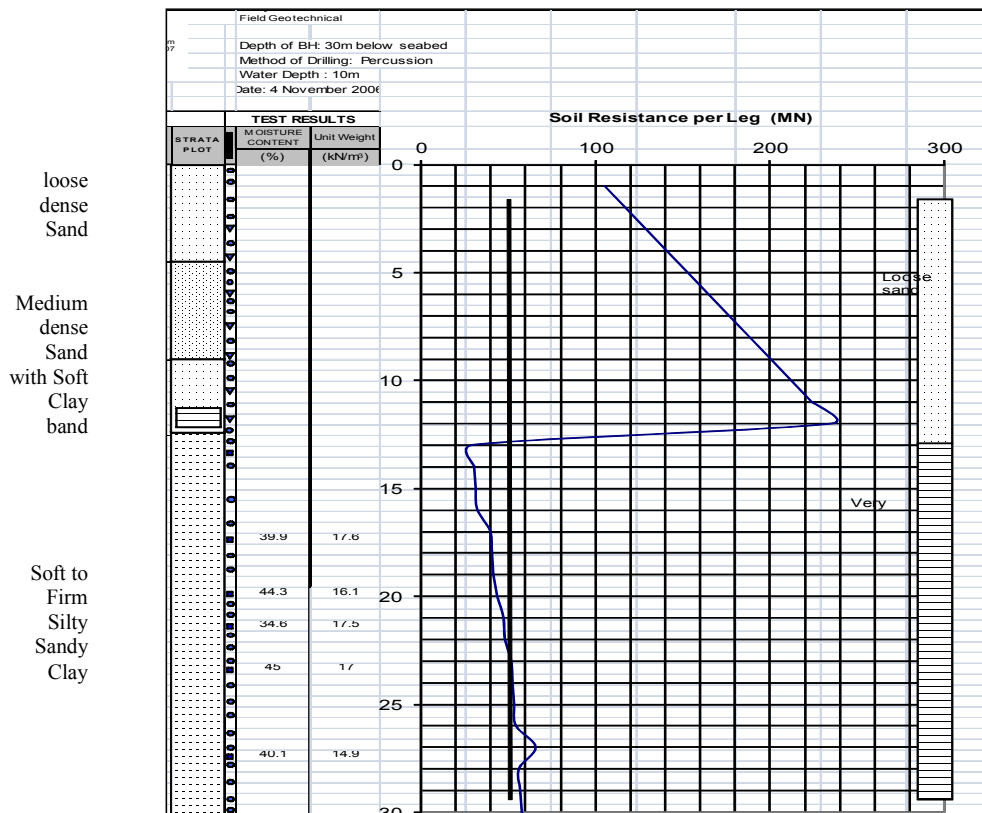

Fig. 12: Soil Penetration Resistance Depth Profile for Otuo North

The variation of p/q_{Δ} for uniformly loaded flexible circular area at the base of the sandy layer was determined as 0.3. In this case, the fraction of the load intensity transmitted to the underlying soft layer is 0.3 of 48MN, which translates 14.4MN. The minimum soil ultimate bearing capacity required to prevent shear failure at the top of the underlying clay sediment was thus calculated to be $14.4MN/144m^2 = 100KN/m^2$. After substitution into the bearing capacity equation, the minimum undrained shear strength that the underlying clay soil should possess to avoid shear failure was estimated to be $6.67KN/m^2$. Since the undrained strength within the underlying soft clay sediments is higher than $7 KN/m^2$, it is reasonable to expect that punch through failure is unlikely, although the risk may not also be eliminated.

The scenario at Otuo South location was similar, a competent upper layer, overlying a relative weaker clayey silt sediments (Fig. 13). The competent upper layer is 3m thick and consists of loose dense sand with SPT -N value of 6. The stress increment beneath a spudcan leg, induced by the fully loaded jack-up determined from equation 3.

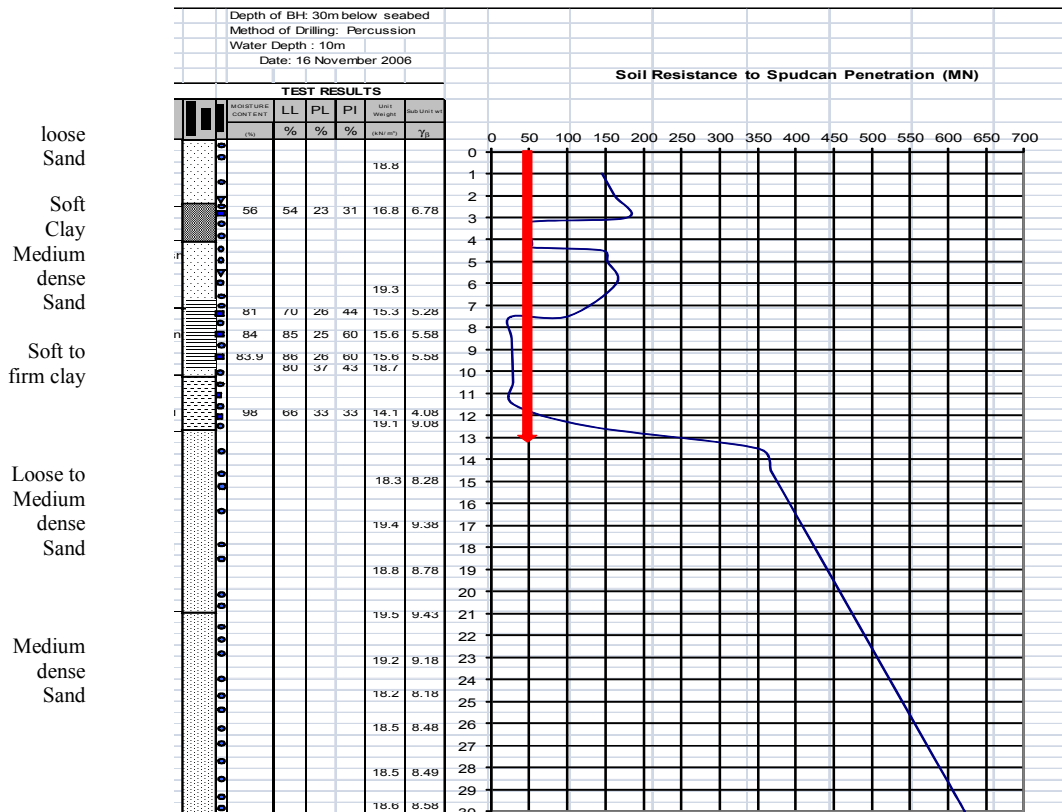

Fig. 13: Soil Penetration Resistance Depth Profile for Otuo South

Again, the variation of p/q_0 for uniformly loaded flexible circular area at the base of the sandy layer is 0.911, thus implying that the fraction of the load intensity transmitted to the underlying soft layer is 0.911 of 48MN, which translates to 43.73MN. The minimum soil ultimate bearing capacity required to prevent shear failure at the top of the underlying clay sediment was evaluated to be $43.73MN / 144m^2 = 310kN/m^2$

Using the bearing capacity, the minimum undrained shear strength that the underlying clay soil should possess to avoid shear failure was estimated to be 48.67 kN/m². Again, since the strength within the underlying soft clay sediments was only marginally higher than 48.67 kN/m², it is reasonable to expect that significant punch through failure exists. In fact, in this case, punch through risks exist at two levels. Between 3m and 4.5m on the one hand, and between 9m and 12m on the other hand. Considering these levels of punch through risks, the spudcan was advanced and perched at 13m below seafloor.

A different soil stratigraphic configuration existed at Ukpokiti Field location. Here, we have a scenario of a very soft upper layer, consisting of a soft silty clay sediments that is 15m. The soft silty clay upper layer appears to increase in undrained strength with depth, with occasional occurrence of thin stony bands of clay. Following analysis, punch through risks were identified between 21 and 25m within this soft silty-sandy clay soil mixed with thin stony bands. In this case, the spudcan penetration legs were driven beyond these horizons and perched at about 30m below the sea floor. Some settlement was expected that would lower the spudcan. At this depth the undrained strength within the underlying clay sediments was higher than that required to maintain stability. Consequently, it was determined that punch through failure was unlikely, although the risk may not be eliminated.

Conclusions

Conventional spudcan penetration predictions carried out by the authors have shown to be in good agreement with observations during rig loading in all the cases. The interaction between jack-up spudcans and the seabed soil are commonly analyzed on the basis of assumption of the application of a static vertical load at the centre of an idealized footing.

References

- Baglioni, VP, Chow, GS and Endley, SN (1982). "Jack-up Rig Foundation Stability in Stratified Soil Profiles", Journal of Offshore Technology, OTC 4409, pp 363-383.
- Craig, W. H. and Chua, K. (1990) *Deep penetration of spudcan foundations on sand and clay*. Geotechnique Vol. 40, No. 4, 541-556,

- Georgiadis, M. and Michalopoulos, A. M. (1985) *Bearing capacity of gravity bases on layered soil*. J. of Geotech. Eng. Vol. 111, No. 6, 712-727,
- Griffiths, D. V. (1982) *Computation of bearing capacity on layered soils*. Proc. 4th Int. Conf. On Num. Meth. In Geomechanics, Vol. 1, 163-170,
- Hanna, A. M. and Meyerhof, G. G. (1980) *Design charts for ultimate bearing capacity of foundations on sand overlying clay*. Canadian Geotech. Journal, Vol. 17, 300-3003
- Hossain M. S. and Hu Y. and Randolph M. F. (2003) Spudcan Foundation Penetration into Uniform Clay. Proceedings of the Thirteenth (2003) International Offshore and Polar Engineering Conference Honolulu, Hawaii, USA, May 25–30, 2003
- Hu, Y. and Randolph, M.F. (1998) *Deep penetration of shallow foundations on nonhomogeneous soil*. Soil and Found. Vol. 38, NO. 1, p. 241-246.
- Kee, R and Ims, BW (1984). “Geotechnical Hazards Associated with Leg Penetration of Jack-up Rigs”, Journal of Seabed Mechanics, pp 169-174.
- Kellezi L, Hofstede H and Hansen P B.(2005) Jack-up footing penetration and fixity analyses, Proc. ISFOG 2005, Sept., Perth, Australia, pp. 559 – 565.
- Mehryar, Z, Hu, Y, and Randolph, MF (2002). "Penetration Analysis of Spudcan Foundations in NC Clay," 12th International Offshore and Polar Engineering Conference, ISOPE, Kitakyushu, Japan, pp 679-684.
- Michalowski, R. L. and Lei S. (1995) *Bearing capacity of footings over two layer foundation soils*. ASCE, J. of Geotech. Eng. Div., Vol. 121, No. 5, 421-427,
- SNAME, (2002)T&R Bulletin 5-5A. Site Specific Assessment of Mobile Jack-Up Units. The Society of Naval Architects and Marine Engineers , January 2002.
- Hansen J B.(1970) A revised and extended formula for bearing capacity,. Bulletin No. 28, The Danish Geotechnical Institute, pp. 5-11.
- Yang, AG, Remmes, BD, and Meyer, BJ (1984). “Foundation Performance of Offshore Jack-up Drilling Rigs”, Journal of Geotechnical Engineering, ASCE, Vol 110, No 7, pp 841-859

The IISTE is a pioneer in the Open-Access hosting service and academic event management. The aim of the firm is Accelerating Global Knowledge Sharing.

More information about the firm can be found on the homepage:

<http://www.iiste.org>

CALL FOR JOURNAL PAPERS

There are more than 30 peer-reviewed academic journals hosted under the hosting platform.

Prospective authors of journals can find the submission instruction on the following page: <http://www.iiste.org/journals/> All the journals articles are available online to the readers all over the world without financial, legal, or technical barriers other than those inseparable from gaining access to the internet itself. Paper version of the journals is also available upon request of readers and authors.

MORE RESOURCES

Book publication information: <http://www.iiste.org/book/>

Academic conference: <http://www.iiste.org/conference/upcoming-conferences-call-for-paper/>

IISTE Knowledge Sharing Partners

EBSCO, Index Copernicus, Ulrich's Periodicals Directory, JournalTOCS, PKP Open Archives Harvester, Bielefeld Academic Search Engine, Elektronische Zeitschriftenbibliothek EZB, Open J-Gate, OCLC WorldCat, Universe Digital Library, NewJour, Google Scholar

