

An Experimental Study on Utilization of Iron Ore Tailings (IOT) and Waste Glass Powder in Concrete

Bakulamba Devi T S¹ Natesh M G² Praveen kumar K S² Archana N² Ashwini sozi²

1.Asst. Professor, Dept. of Civil Engineering CIT, Gubbi

2.Bachelor of Engineering, Dept. of Civil Engineering CIT, Gubbi

Abstract

Cement manufacturing industry is one of the carbon dioxide emitting sources besides deforestation burning of fossil fuels. The global warming is caused by the emission of green house gases, such as CO₂, to the atmosphere. Among the greenhouse gases, CO₂ contributes about 65% of global warming. The global cement industry contributes about 7% of green house gas emission to the earth's atmosphere. In order to address environmental effects associated with cement manufacturing, there is a need to develop alternative binders to make concrete. Consequently extensive research is on going into the use of cement replacements, using many waste materials industrial by products. Efforts have been made in the concrete industry to use waste glass as partial replacement of cement and also in recent years almost every mineral producing country is facing the problem of better utilization of mine waste because of its accumulation lack of suitable storage space. In this study, finely powdered waste glass from industries and Iron Ore Tailings (IOT) produced from mining areas are used as a partial replacement of cement and fine aggregates in concrete respectively. This work examines the possibility of using Glass powder and iron ore tailing as a partial replacement of cement and fine aggregate in concrete. In the present study Glass powder and Iron Ore Tailing (IOT) are partially replaced by 10%, 20%, 30% and 40% tested for its compressive, flexural strength for 7, 28 and 56 days of curing and were compared with those of conventional concrete.

Keywords: Glass Powder – GP, Iron Ore Tailings – IOT, Conventional Concrete - CC

INTRODUCTION

Throughout the world, concrete is being widely used for the construction of most of the Buildings, bridges etc. Hence, it has been labelled as the backbone to the infrastructure development of a nation. Currently, our country is taking major initiatives to emerge as a major economic power, to improve and develop its infrastructure by constructing express highways, power projects and industrial structures hence to meet out this rapid infrastructure development a huge quantity of concrete is required. Unfortunately, India is not self sufficient in the production of cement i.e. the main ingredient of concrete and the demand exceeds the supply and makes the construction activities very costlier. Hence, the entire construction industry is in search of a suitable and effective waste product that would considerably minimize the use of cement and ultimately reduce the construction cost. The consequent increasing of wastes, coming from electronic and electrical devices, requires recycling technically and economically feasible. Few of such products have already been identified like Glass Powder, Rubber tyres, Rice Husk Ash (RHA), Fly Ash, Silica Fumes, Egg shell etc.

Much of the glass produced in the World is discarded, stockpiled or land filled. This pattern has influenced environmental organizations to pressure the professional community to lower the amount of glass being discarded as well as find use to the non-recycled glass in new applications. The waste glass is one of the issues of environmental problem. Glass is used in a variety of applications right from construction, automobiles, nose-diving submarines, doors and windows, utensils, waste containers, windscreen, medicinal bottles, soft-drink bottles, tube lights, bulbs, electronic equipments, etc. Hence, the usage of glass has increased considerably, which has in essence, contributed to the increase of waste disposal. In addition, glass waste is considered as non-decaying material that pollutes the surrounding environment.

Many researchers have thus come forward and have investigated usage of this waste glass into something of productive value. One such group of research scholars has highlighted the usage of glass in powdered form as a partial replacement of cement in concrete. In relation, the recycling of waste glass as a component in concrete gives waste glass a sustainable alternative to land filling and therefore makes it economically viable. A variety of public and private research was investigated to understand the limitations of glass concrete and its properties. Results found were promising as strength tests showed the glass concrete mixtures in question to have moderate to high strengths which shows that a concrete derived from recycled glass could be effectively applied to a multitude of services including structural applications. There is considerable interest in the use of recycled glass with port land cement in making a variety of different types of cement products. This interest has been motivated by the large quantity of recycled glass available through municipal recycling programs which far exceeds the demand for such glass from conventional markets like container manufacturers. If glass could be incorporated in cement products, it would greatly reduce the disposal of recycled glass and/or its use in lower valued markets such as fill and road base material. The waste glass is one

of the issues of environmental problem. Glass is used in a variety of applications right from construction, automobiles, nose-diving submarines, doors and windows, utensils, waste containers, windscreen, medicinal bottles, soft-drink bottles, tube lights, bulbs, electronic equipments, etc. Hence, the usage of glass has increased considerably, which has in essence, contributed to the increase of waste disposal. In addition, glass waste is considered as non-decaying material that pollutes the surrounding environment. Many researchers have thus come forward and have investigated usage of this waste glass into something of productive value. One such group of research scholars has highlighted the usage of glass in powdered form as a partial replacement of cement in fibre reinforced concrete.

Iron ore tailings:

India is one of the important iron ore producers and exporter in the world. However, the rapid growth in production, especially from large surface mines, have already caused ecological imbalance in their respective regions and emerge as the source of main environmental hazards. The waste/tailings that are ultra-fines or slimes, having diameter less than 150 μm , are not useful and hence are discarded. In India approximately 10 –12 million tons of such mined ore is lost as tailings. The safe disposal or utilization of such vast mineral wealth in the form ultra-fines or slimes has remained a major unsolved and challenging task for the Indian iron ore industry. In future, the proportion of iron ore wastes generated is likely to increase due to higher demand for iron ore as a number of steel plants have been planned for future in many parts of the country. In order to reduce the adverse impact of indiscriminate mining of natural sand, iron ore tailings which is the waste products of mining industries is used as an alternative to the river sand in the manufacturing of concrete. The KIOCL company which was a leading company in India in the mining activities of iron ore has dumped about 200 million metric tons of iron ore tailings at Lakya Dam. The company conducted mining for more than 25 years in Kudremukh until it stopped mining in 2005. In the process of beneficiation, it has dumped iron ore tailings in Lakya Dam, which was constructed as an ecological dam for this purpose.

OBJECTIVES OF THE STUDY

- 1) To determine the properties of waste glass powder and iron ore tailings and comparing the result with conventional cement and fine aggregate respectively.
- 2) Partial replacement of waste glass powder and iron ore tailings with cement and fine aggregate respectively and comparing the result with conventional concrete.
- 3) To determine the strength properties of concrete for 7, 28 and 56 days.
- 4) To economically compare conventional concrete with the concrete modified using waste glass powder and iron ore tailings.
- 5) To determine the optimum (%) waste glass powder and IOT content to be added as a partial replacement of cement and fine aggregate.

METHODOLOGY

2.1 Cube Compressive Strength Test:

Cube specimen of CC, GP and IOT are prepared as per mix proportion and tested in a compressive testing machine, as per IS: 516-1976. The specimens of CC, GP and IOT are tested for compressive strength at 7, 28 and 56 days of curing.

2.2 Flexural Strength Test:

The flexure strength of CC, GP & IOT beam specimens were determined using two point loading method. The two point loading method with the forces applied perpendicular to the beam without eccentricity is shown in Fig 3.1. Loading is done continuously without any shock. Reaction shall be parallel to the direction of the applied force at all times during the test and the ratio of distance between the point of load application and nearest reaction to the depth of the beam shall not be less than zero.

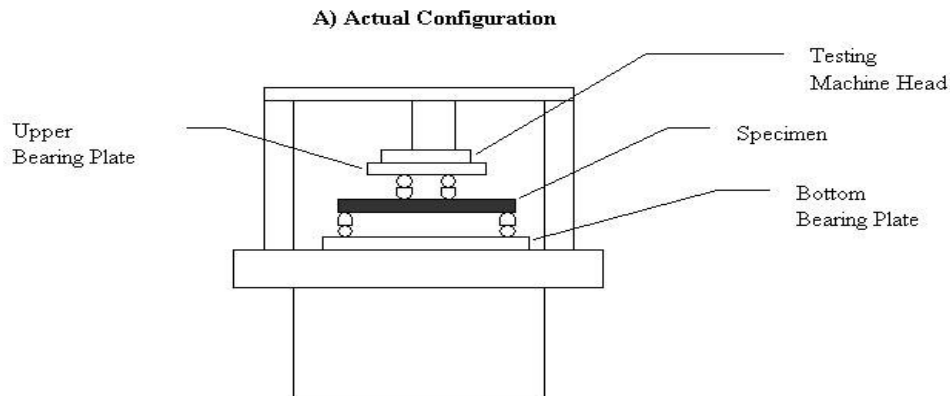

Figure 3.1 Flexural Test of Concrete by Two Point Loading

RESULTS AND CONCLUSION

4.1 Results:

Conventional concrete shows at 28, 56 days compressive strength as 37.47, 39.18 N/mm² and flexural strength as 4.86, 5.46 N/mm² respectively.

Replacement of GP in cement by 10% and IOT in fine aggregate by 10% shows at 28, 56 days compressive strength as 39.62, 48.43 N/mm² and flexural strength as 5.6, 6.13 N/mm² respectively.

Replacement of GP in cement by 20% and IOT in fine aggregate by 20% shows at 28, 56 days compressive strength as 38.29, 50.81 N/mm² and flexural strength as 6.13, 6.26 N/mm² respectively.

Replacement of GP in cement by 30% and IOT in fine aggregate by 30% shows at 28, 56 days compressive strength as 32.59, 36.58 N/mm² and flexural strength as 6.06, 6.4 N/mm² respectively.

Replacement of GP in cement by 40% and IOT in fine aggregate by 40% shows at 28, 56 days compressive strength as 30.29, 34.29 N/mm² and flexural strength as 5.3, 5.66 N/mm² respectively.

4.2 Conclusion:

On addition of GP and IOT in Concrete, initially the rate of gain of strength is low but at 28th and 56 days curing it meets required design strength.

At the level of 20% replacement of cement by GP and 20% of fine aggregate by IOT meets maximum compressive strength as compared to that of normal concrete.

At the level of 30% replacement of cement by GP and 30% of fine aggregate by IOT meets maximum flexural strength as compared to that of normal concrete.

SCOPE OF FUTURE WORK

As a continuation of study there are good scopes to undertake further work in similar lines. Some of them are listed below:

Further studies can be carried out for varying % of GP and IOT.

REFERENCES

1. Mr. T I. Ugama, Mr. S P. Ejeh, Mr. D Y Amartey
"Effect of Iron Ore Tailing on the Properties of Concrete" (ISSN) 2224-5790 (Paper) ISSN 2225-0514 (Online)
Volume.06, Issue Jan 10, 2014
2. Mr. B N Skanda Kumar, Mr. Suhas R, Mr. Santosh Uttam Shet, Mr. J M Srishaila.
"Utilization of iron ore tailings as replacement to fine aggregate in cement concrete pavement" (IJRET)
Volume.03, Issue: 07/July-2014
3. Mr. Bhupendra Singh Shekhawat, Dr. Vanita Aggarwal
"Utilization of Waste Glass Powder in Concrete" (IJIRSET) Volume: 03, Issue7, July 2014.
4. Dr. G. Vijayakumar, Ms H. Vishaliny, Dr. D. Govindarajulu
"Studies on Glass Powder as Partial Replacement of Cement in Concrete Production" (IJETA) Volume 03,
Issue: 2, Feb 2013.

The IISTE is a pioneer in the Open-Access hosting service and academic event management. The aim of the firm is Accelerating Global Knowledge Sharing.

More information about the firm can be found on the homepage:

<http://www.iiste.org>

CALL FOR JOURNAL PAPERS

There are more than 30 peer-reviewed academic journals hosted under the hosting platform.

Prospective authors of journals can find the submission instruction on the following page: <http://www.iiste.org/journals/> All the journals articles are available online to the readers all over the world without financial, legal, or technical barriers other than those inseparable from gaining access to the internet itself. Paper version of the journals is also available upon request of readers and authors.

MORE RESOURCES

Book publication information: <http://www.iiste.org/book/>

Academic conference: <http://www.iiste.org/conference/upcoming-conferences-call-for-paper/>

IISTE Knowledge Sharing Partners

EBSCO, Index Copernicus, Ulrich's Periodicals Directory, JournalTOCS, PKP Open Archives Harvester, Bielefeld Academic Search Engine, Elektronische Zeitschriftenbibliothek EZB, Open J-Gate, OCLC WorldCat, Universe Digital Library, NewJour, Google Scholar

