

Structural Design: Technology and Computerization Not the Problem

Lamuo Francis Suglo*

Department of Civil Engineering, PDM University, Sector 3A, Sarai Aurangabad, Bahadurgarh-India

Jai Prakash Nayak

Assistant Professor, Department of Civil Engineering, PDM University, Sector 3A, Sarai Aurangabad Bahadurgarh-India

Abstract

The building industry is a double-faced demon. On one hand, it takes upon itself to help contain the challenges of overpopulation and urbanization by providing infrastructure and shelter to the current explosive population. On the other hand, it remains an unrepentant contributor of CO² emissions to the environment up to 30% (N. Subramaman, 2007). It also remains the biggest consumer of extracted materials such as steel, bauxite and sand mined from the environment. The process of extracting these materials to satisfy this need often leave the environment depleted and polluted. The advent of computers has further exposed the industry to much complexities. Engineers have adapted to the use of computer based software to perform designs, analysis and specifications for buildings and structures. The advantages being the improvement in the accuracy of results, efficiency and reduction in time. However, these softwares can also impact negatively on the designs and sustainable construction. It is in this regard that this paper presents the results of an analysis and design of a G+5 building from STAAD Pro and ETABS respectively. The methodology employed involved the calculation of loads in both software according to the load combinations defined in IS 456:2000. The load is categorized analyzed as dead load (IS 875: Part 1), live load (IS 875: Part 2). The loads analyzed were then used to size the structural members. The following factors; resource conservation, cost efficiency and design for human adaptation were targeted for satisfaction. It was observed that the user must possess enough experience, knowledge in structural behavior, have a strong grasp of structural analysis to be able to manually check reports from the computer as well as have the ability to creatively think about the problems that are to be analyzed in order to improve the accuracy and efficiency of the design. It has also been observed from the percentage of steel data from ETABS, that, the cost of the project can be greatly influenced. The total quantity of reinforcement of 227374 N of 8mm, 10mm, 12mm, 16mm, 20mm and 25mm diameter bars were provided by STAAD Pro where as ETABS provided only areas of steel reinforcement. These provisions were compliant with the provisions of IS 456:2000 upon verification. Smart and cost effective as well as efficiently designed buildings can thus be employed to make construction sustainable.

Keywords: computers, analysis, cost, efficient design

1. Introduction

Engineers have the outmost duty of ensuring that the construction industry fulfills its function of providing the needed infrastructure to shelter the growing population, driving the economies of the world and making human lives comfortable. With this duty, there is a call to action on how to improve construction practices in order to improve sustainability since the construction industry is a great contributor to our environmental issues (Cole, 1999; Holmes & Hudson, 2000). The design stage is a key stage to consider sustainability. This involves ensuring there is a balance between economic, social and environmental issues (Peter O. Akadiri et al, 2012). As population continues to increase, sustainability of many resources including land has become paramount. Vertical expansion, judicious of materials as well as efficient, serviceability and cost effective design are some of the challenges the engineer must overcome.

A common problem however, which has very serious implication on sustainable development as far as design is concern, is that, modern structural engineers are tending to replace human knowledge and critical thinking with the computer as a tool for structural analysis and design (Devdas Menon, 2009).

The argument for this paradigm shift is the need to keep up with global competition as population continue to soar exponentially and the construction industry races to contain same by providing infrastructure. However, this need to do analysis faster and quicker is so strong that there is no time to pause and reflect. And as many modern structural engineers depend on analysis manuals that come with the software package to operate and use the software for analysis, the power of the computer as a tool may be limited to garbage in garbage out (S. S. Bhavikatti, 2005). The choice of a software for analyzing a project is usually tied to several factors including personal preference, ease of use, accuracy of performance and efficiency.

In the preface to his book; Advance Structural Analysis, Devdas Menon strongly emphasized the dangers involved for the structural engineer to make the computer his/her master if human knowledge, experience and

critical thinking is replaced by it. Structural engineers will become “endangered species” with such a trend.

This paper sought to compare the results of two of the most commonly used analysis software STAAD Pro and ETABS. It also sought to determine influence of over reliance on software packages for structural design on the cost efficiency requirement of sustainable design and construction.

2. Literature review

Since the explosion in population, the technique of managing the scarce land has brought about complex structures, high-rise buildings and multi-bay-multi-storey buildings. This advent has made structural analysis of multi-storey buildings cumbersome and daunting. M. Mallikarjun and S. Prakash (2016) opined that structural analysis appears simple in context but is actually complex in detail. The availability of computers in the 1950s did revolutionized the face of structural analysis (Aslam Kassimali, 2011).

Since then, there has been a growing demand and emphasis on the use of computer application software for structural analysis. ETABS is such a significant tool for the structural analysis. It can be used for steel and concrete structures, low and high rise structures as well as portal frames (Rinkesh R. B, 2017). Rinkesh R. B and others used ETABS to analyze and design a multi-storey building and found that, shear walls performed better when compared to framed structures. They found shear structures to be suitable in earthquake prone areas because it has higher stiffness but little displacement.

In a similar study carried out by Harry N. N. et al (2016), a seismic analysis was carried out on building structures using STAAD Pro and they found the fundamental natural period requirement of IS 1893:2002 satisfied by the STAAD Pro analysis results. Other code provisions such as displacement in beams and maximum drift were also found to have been met. Their design was also found to be safe under earthquake zone II.

According to Jain I. M (2016), a STAAD Pro analysis of a G+19 building demonstrated the versatility of the software. He concluded the software could give reinforcement details, quantities and the results satisfied the provisions of all IS codes used. In his conclusion, he observed a lot of application software exist for civil engineering work (Gajendra, 2016). He used STAAD Pro to analyze and design a multi-storey and the structural components were safe in shear and flexure and the steel areas provided was found to be economic. The short term deflection which was recorded as 20mm was within a safe limit.

Through his study in 2014, Abhay Guleria found out from an ETABS analysis of multi-storey buildings for different plan configuration that, storey overturning moment is inversely proportional to storey height. Storey drift displacement was found to have reached its maximum at the 6th floor of the storey building and then begun decreasing with each additional storey of floor.

Sayyed A. Ahad et al (2015) did an analysis and design of B+G+10 multi-storey apartment building and concluded ETABS is a premium software in the analysis and design of structures. Similar results were recorded when Sekhar U. P. (2017), conducted an analysis on a G+4 residential building with ETABS. They found the design economic.

No effort has however been attempted to compare results from two or more analysis methods and the influence of such results on cost of the structure as well as sustainability. This is the gap this paper seeks to bridge.

3. Methodology

The methodology employed involves the calculations of load according to the load combinations defined in IS 456:2000. The load is categorized and analyzed as dead load (IS 875: Part 1) and live load (IS 875: Part 2). The analysis was done using ETABS and STAAD Pro software. They allow structural engineers to create, modify, analyze, design, and optimize building models. Their features are fully integrated in a single, windows-based, graphical user interface that is unmatched in terms of ease-of use, productivity, and capability (M. Mallikarjun and S. Prakash, 2016).

3.1 Analysis and Design Procedure

The following steps were followed in the analysis and design of the problem under study.

3.2 Preparation of Plan in AutoCAD

A G+5 storey building plan was prepared in AutoCAD as a proposed residential facility for the faculty of PDM University. In each floor there are four bedrooms. It has a gross area of 271.83m² and total useable area of 230.96m².

3.3 Importing Drawing File into Analysis Software

The AutoCAD drawings were imported into ETABS and STAAD Pro. Since both software support 3-D, the imported drawing was modelled in 3-D. Geometrical shapes of beams and other structural members were

defined, and concrete as well as steel properties were also assigned to the columns, beams and floors structural members.

3.4 Design data:

The plan for analysis is provided with model geometry information, including items such as story levels, point coordinates, and element connectivity.

4. Results and discussion

The limit state method was employed in the analysis and design. All safety factors were considered and the structure has been designed to safely withstand all loads liable to act on it for its entire life. It is a serviceable structure, as it did satisfy the serviceability requirements. The sections designed were adequate against bending moment, shear and deflection according to the provision of the IS code.

However, both software returned huge data output. Over 1000 pages' report was generated by each software. Similarly, errors reported were equally high. These errors pertain to the model that was defined for analysis in the software. Therefore, the quality of results obtained from a software package is accurate to the extent that the input data has been defined. It can be argued that lack of experience and poor understanding of structural behavior will make it very difficult to detect problems in these voluminous reports. This will not only affect the integrity of the structure but will also be impeding the achievement of cost efficient designs which are essential for sustainability.

4.1 Steel areas and steel quantities

The minimum percentage of reinforcement to be provided per the IS code is 0.8%. It was observed that STAAD Pro recorded the exact values (Fig. 3) for cases where the percentage of reinforcement at a section is below 0.8%. ETABS however recorded 0.8%, the minimum requirement for the same cases (Table 2). Steel is an expensive material. Excess quantities will impact heavily on the overall cost of the project. Its impact may be minimal for low rise buildings. But for very high buildings and skyscraper, the impact will be huge. The dead load of the structural elements will also increase and it can be challenging to use slender members for columns.

In table 3 above, STAAD Pro gives the most economical area of steel for columns of 400mmx300mm. For the beams however, it gives the highest areas of steel. It can be argued that it is providing more steel than is required since it returns the exact percentage of steel required for a section even if it is below the 0.8% minimum required by the code or ETABS is not providing adequate steel for the beams.

5. Conclusion

An analysis and design on a proposed residential building having G+5 storey is done. The flexibility and ease of using ETABS and STAAD Pro for the analysis proved that a software is of great potential in analysis and design of various structural members and sections. However, it was observed that the user must possess enough experience, knowledge in structural behavior, have a strong grasp of structural analysis to be able to manually check reports from the computer as well as have the ability to creatively think about the problems that are to be analyzed in order to improve the accuracy and efficiency of the design. It has also been observed from the percentage of steel data from ETABS that, the cost of the project can be greatly influenced.

References

1. Abhay Guleria (2014). "Structural Analysis of a Multi-Storeyed Building using ETABS for different Plan Configurations". *International Journal of Engineering Research & Technology (IJERT)* ISSN: 2278-0181 IJERTV3IS051552 Vol. 3 Issue 5, May – 2014 www.ijert.org
2. Aslam Kassimali, (2011). "Structural Analysis, Fourth Edition, SI". ISBN-13:978-0-495- 29567-9. Cengage Learning, 200 First Stamford Place, Suite 400, Stamford, CT 06902, USA
3. Cole, R.J., 1999. *Building environmental assessment methods: clarifying intentions*. *Building Research and Information*, 27 (4/5), 230–246.
4. Devdas Menon (2009). *Advance Structural Analysis*. Narosa Publication, ISBN 8173199396,9788173199394.
5. Gajendra , Aman, Manjunath Nalwadgi and Vishal T (2016). "Analysis and design of multistorey building by using STAAD Pro". *International Research Journal of Engineering and Technology (IRJET)* e-ISSN: 2395 -0056 Volume: 03 Issue: 06 | June-2016. Accessed online at: www.irjet.net.
6. Harry N.N., Anoop Singh, Vikas Srivastava, (2016). "Seismic Analysis and Design of Building Structures in STAAD Pro" *International Journal of Innovative Research in Science, Engineering and Technology (An ISO 3297: 2007 Certified Organization)* Vol. 5, Issue 7, July 2016 DOI:10.15680/IJRSET.2016.0507013
7. Holmes, J. & Hudson, G., 2000. *An evaluation of the objectives of the BREEAM scheme for offices: a local case study*. Proceedings of Cutting Edge 2000, RICS Research Foundation, RICS, London.
8. Indian standard codes 456:2000, 875 Parts 1-5

9. Jain I. M, D.R. Deshmukh.et al. (2016). “*Analysis and Design of G+19 Storied Building Using Staad-Pro*” *International Journal of Engineering Research and Application* ISSN: 2248-9622, Vol. 6, Issue 7, (Part -1) July 2016, pp.17-19; Accessed from www.ijera.com
10. M.Mallikarjun and Dr P V Surya Prakash (2016). “*Analysis and Design of a Multi Storied Residential Building of (Ung-2+G+10) By Using Most Economical Column Method*”, *International Journal of Science Engineering and Advance Technology, IJSEAT, ISSN 2321-6905 FEBRUARY-2016 Vol. 4, Issue 2*
11. N. Subramanian (2007). *The Indian Concrete Journal*. Accessed online from http://www.thestructuralengineer.info/library/papers/Sustainability_Challenges_and_solutions.pdf
12. Peter O. Akadiri, Ezekiel A. Chinyio and Paul O. Olomolaiye (2012). *Design of A Sustainable Building: A Conceptual Framework for Implementing Sustainability in the Building Sector*. ISSN 2075-5309. *Buildings* 2012, 2, 126-152; doi:10.3390/buildings2020126
13. Rinkesh R Bhandarkar ,Utsav M Ratanpara, and Mohammed Qureshi (2017). “*Seismic Analysis & Design of Multistory Building Using Etabs*” *International Journal of Engineering Development and Research, Volume 5, Issue 2 | ISSN: 2321-9939*. Accessed online at: www.ijedr.org
14. Sayyed A.Ahad, Hashmi S Afzal, Pathan Tabrej, Shaikh Ammar et al (2015). “*Analysis and Design of Multistory Apartment Building Using ETABS*” *International Journal of Engineering and Computer Science* ISSN:2319-7242 Volume 6 Issue 5 May 2017, Page No. 21269-21285 Index Copernicus value (2015): 58.10 DOI: 10.18535/ijecs/v6i5.13. Accessed online at: www.ijecs.in
15. S. S. Bhavikatti (2005). *Finite Element Analysis*. New Age International Publishers, ISBN 9788122425246, New Delhi
16. U.P.B.C. Sekhar, C.V.S. Lavanya, Emily.P.Pailey, Md.and Mansha Sabreen (2017). “*Analysis and Design of G+4 Residential Building Using Etabs*” *International Journal of Civil Engineering and Technology (IJCIET) Volume 8, Issue 4, April 2017, pp. 1845–1850 Article ID: IJCIET_08_04_210* Accessed online at <http://www.iaeme.com/IJCIET/issues.asp?JType=IJCIET&VType=8&IType=4> ISSN Print: 0976-6308 and ISSN Online: 0976-6316

TABLE 1: Data used for analysis and design of G+5 proposed building

Structural element/Material	ETABS	STAAD Pro
Beams	400mm x 300mm	400mm x 300mm
Column	350mm x 350mm	350mm x 350mm
Grade of concrete	M30	M30
Grade of Steel	Fe415	Fe415
Column heights	Ground -4 th floor	3000mm
	Fifth and sixth floor	2850mm
Total height of building	17700mm	

Table 2: Output data from ETABS showing 0.8% rebar for sections that have less than or equal to the minimum required 0.8% steel

Label	Story	Section	Location	P kN	M Major kN-m	M Minor kN-m	PMM Combo	PMM Ratio or Rebar %
C1	Story6	co350x350	Top	116.5014	21.7756	-13.4472	DCon2	0.8 %
C1	Story6	co350x350	Bottom	178.4677	-23.1604	12.9176	DCon2	0.8 %
C2	Story6	co350x350	Top	149.5008	30.3996	27.7132	DCon2	0.8 %
C2	Story6	co350x350	Bottom	211.4672	-32.6018	-33.3103	DCon2	0.8 %
C3	Story6	co350x350	Top	108.0818	26.0835	21.1626	DCon2	0.8 %
C3	Story6	co350x350	Bottom	170.0481	-27.3447	-25.3387	DCon2	0.8 %
C4	Story6	co350x350	Top	196.4405	40.3822	33.1548	DCon2	0.8 %
C4	Story6	co350x350	Bottom	258.4069	-45.0521	-37.7306	DCon2	0.8 %
C5	Story6	co350x350	Top	242.0002	-4.84	15.3713	DCon2	0.8 %
C5	Story6	co350x350	Bottom	303.9665	6.0793	-18.2418	DCon2	0.8 %
C6	Story6	co350x350	Top	245.5654	-21.1755	26.3914	DCon2	0.8 %
C6	Story6	co350x350	Bottom	307.5318	23.9954	-28.5093	DCon2	0.8 %
C7	Story6	co350x350	Top	245.215	20.2936	26.5714	DCon2	0.8 %
C7	Story6	co350x350	Bottom	307.1814	-22.7656	-28.7267	DCon2	0.8 %
C8	Story6	co350x350	Top	197.649	-19.3008	-29.6279	DCon2	0.8 %
C8	Story6	co350x350	Bottom	259.6154	21.8293	34.6539	DCon2	0.8 %
C9	Story6	co350x350	Top	197.6318	17.9668	-29.4257	DCon2	0.8 %
C9	Story6	co350x350	Bottom	259.5982	-20.007	34.3788	DCon2	0.8 %
C10	Story6	co350x350	Top	81.6363	-12.6113	-31.1344	DCon2	0.8 %
C10	Story6	co350x350	Bottom	92.8877	12.8457	35.4349	DCon2	0.8 %
C11	Story6	co350x350	Top	73.9778	13.9559	-31.6379	DCon2	0.8 %
C11	Story6	co350x350	Bottom	85.2291	-13.5964	36.1911	DCon2	0.8 %
C12	Story6	co350x350	Top	202.6286	17.5875	-35.8052	DCon2	0.8 %
C12	Story6	co350x350	Bottom	264.595	-20.0171	42.387	DCon2	0.8 %
C13	Story6	co350x350	Top	271.1098	19.001	29.9684	DCon2	0.8 %
C13	Story6	co350x350	Bottom	333.0761	-22.0772	-36.1481	DCon2	0.8 %
C14	Story6	co350x350	Top	183.3831	-3.6677	-20.1763	DCon2	0.8 %
C14	Story6	co350x350	Bottom	245.3494	4.907	19.6875	DCon2	0.8 %
C15	Story6	co350x350	Top	232.0688	-4.6414	34.0224	DCon2	0.8 %
C15	Story6	co350x350	Bottom	294.0352	-5.8807	-40.9355	DCon2	0.8 %
C16	Story6	co350x350	Top	175.6897	3.5138	27.3122	DCon2	0.8 %
C16	Story6	co350x350	Bottom	237.6561	-4.7531	-32.933	DCon2	0.8 %
C17	Story6	co350x350	Top	196.9324	-38.359	34.1979	DCon2	0.8 %
C17	Story6	co350x350	Bottom	258.8988	42.4528	-39.3641	DCon2	0.8 %
C18	Story6	co350x350	Top	81.018	11.5713	-31.0825	DCon2	0.8 %
C18	Story6	co350x350	Bottom	92.2693	-11.3743	35.3412	DCon2	0.8 %
C19	Story6	co350x350	Top	74.493	-14.4226	-31.5476	DCon2	0.8 %
C19	Story6	co350x350	Bottom	85.7444	14.5009	35.996	DCon2	0.8 %
C20	Story6	co350x350	Top	204.589	-14.4574	-35.6973	DCon2	0.8 %
C20	Story6	co350x350	Bottom	266.5554	15.8262	42.051	DCon2	0.8 %
C21	Story6	co350x350	Top	271.4228	-14.8686	31.3824	DCon2	0.8 %
C21	Story6	co350x350	Bottom	333.3892	16.2193	-37.8044	DCon2	0.8 %
C22	Story6	co350x350	Top	116.5014	-21.7756	-13.4472	DCon2	0.8 %
C22	Story6	co350x350	Bottom	178.4677	23.1604	12.9176	DCon2	0.8 %
C23	Story6	co350x350	Top	149.5008	-30.3996	27.7132	DCon2	0.8 %
C23	Story6	co350x350	Bottom	211.4672	32.6018	-33.3103	DCon2	0.8 %
C24	Story6	co350x350	Top	108.0818	-26.0835	21.1626	DCon2	0.8 %
C24	Story6	co350x350	Bottom	170.0481	27.3447	-25.3387	DCon2	0.8 %

TABLE 3: Output of areas of steel from ETABS and STAAD Pro

AREA OF STEEL		ETABS	STAAD Pro
For columns	Minimum	389.18mm ²	163.15 mm ²
	Maximum	980mm ²	980mm ²
For beams	Top-minimum	95 mm ²	92.34 mm ²
	Top-maximum	709 mm ²	816.84 mm ²
	Bottom-minimum	95 mm ²	92.34 mm ²
	Bottom-maximum	504 mm ²	1018.43 mm ²
For shear	Minimum	1465.3 mm ²	996.4 mm ²
	Maximum	333.59 mm ²	229.4 mm ²

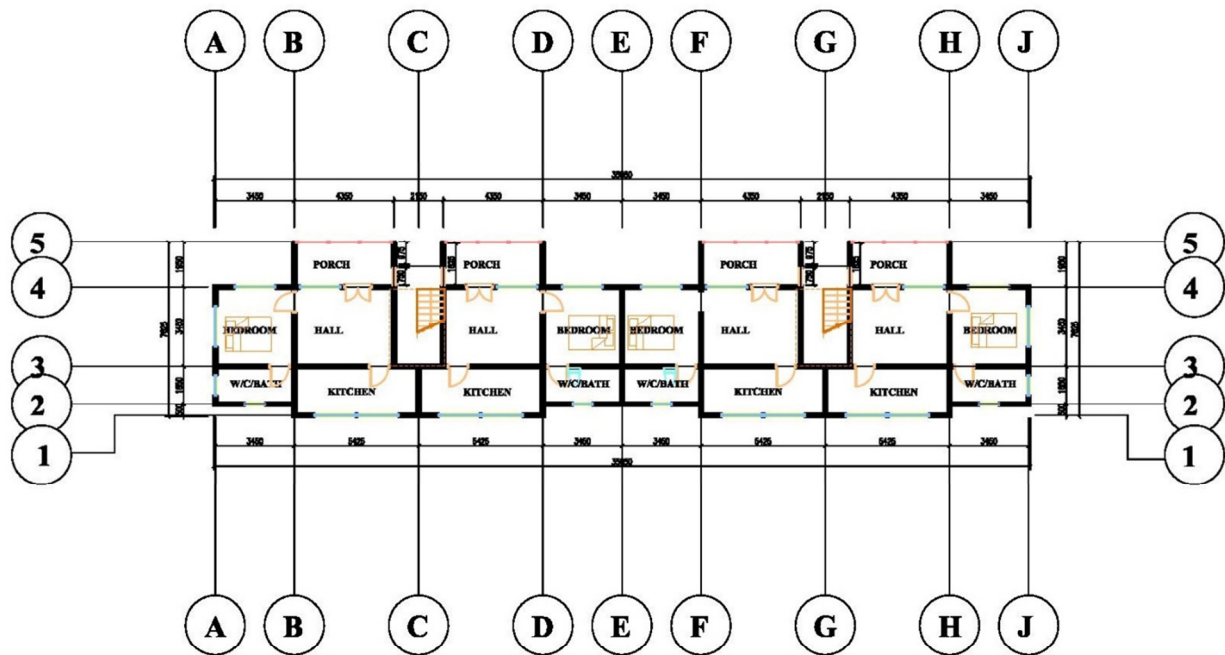

Proposed Ground Floor plan of Faculty accommodation at PDM University

Figure 1: Floor plan of proposed G+5 building prepared in AutoCAD for analysis

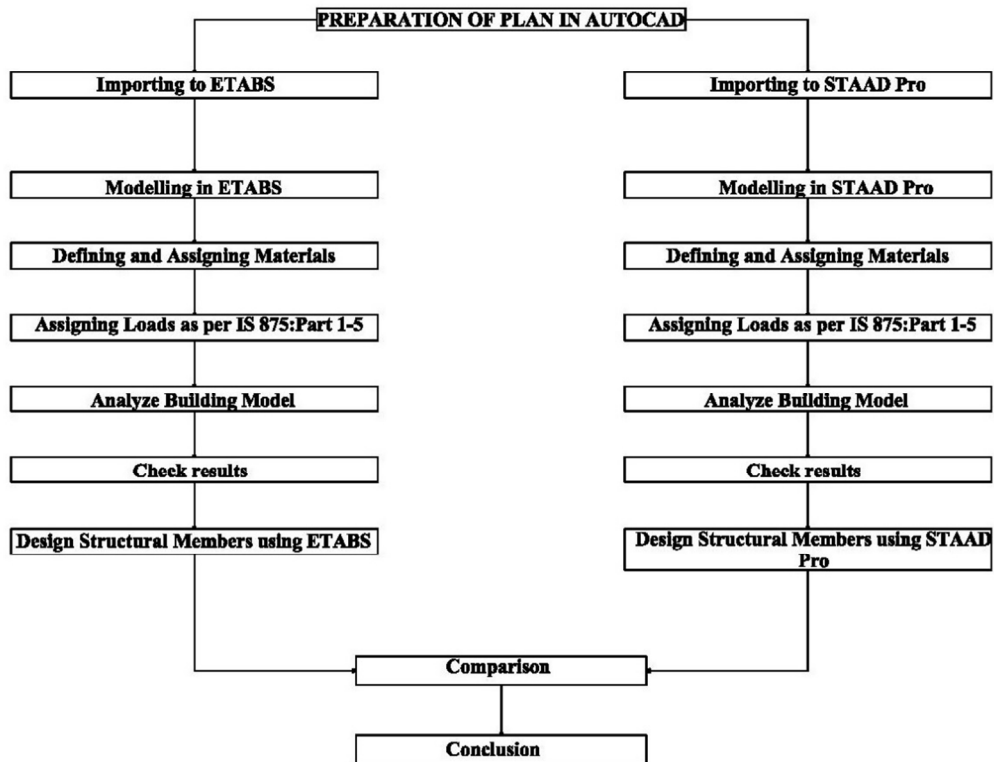

methodology flow chart

Figure 2: Flowchart showing the procedure used in the analysis and design of G+5 proposed building

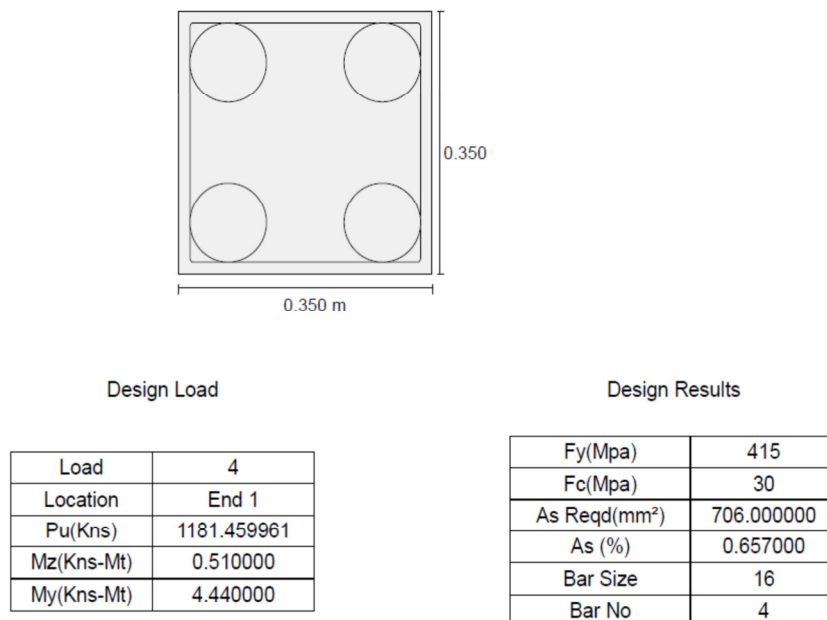

Figure 3: Output data from STAAD Pro showing exact recording of steel areas less than the 0.8% minimum required