

The Simulation of the TBP Curve of Thymol Essence and the Separation of Natural Components with ASPEN plus Software

Varasteh Nobari A.¹, Tahmasebi H.A.², Aghili S.³

1.Department of Chemical Engineering, Shahroud Branch, Islamic Azad University, Shahroud, Iran
varasteharsalan@gmail.com

2.Department of Chemical Engineering, Quchan Branch, Islamic Azad University, Quchan, Iran
hatahmasebi@yahoo.com

3.Department of Chemical Engineering, Quchan Branch, Islamic Azad University, Quchan, Iran
Sinaaghili@hotmail.com

Abstract

Based on the analysis of GCMASS device, the components of the type of Thymol essence prepared from Nishabour maintains, consist of five main components namely, α -Pinene, α -Terpinene, P-Cymene, γ -Terpinene, and Thymol, each of which has the percentage of 1.118, 3.831, 25.815, 14.771, and 54.465 respectively in the essence. Moreover, based on the experiment, the boiling point curve for this essence was achieved, and according to the results of the analysis of the boiling point curve, the simulation for this complex mixture for achieving the characteristics of the essence was done. The simulation of the separation unit of the main components in the pressure range of 44KPa to 101.3KPa showed that with the increase of the pressure, Thymol mole fraction increases from 0.9399 to 0.9496 in the product of the bottom of the distillation column. With the increase of the total pressure of the distillation column from 44KPa to 101.3KPa, the minimum of the return reflux decreases from 17.7 to 13.93.

Keywords: Simulation; TBP; Thymol Essence; Separation; ASPEN plus

1. Introduction

1.1 Recognizing Thymol Essence

Since Thymol essence is aromatic, it is used in food industry, perfume & cosmetics industry, pharmaceutical industry, and generally in all industries which make aromatic products or some products with a special taste. In this study, laboratory & theoretical studies, and the simulation of the separation unit of the main components of Thymol essence has been done. According to the analysis of GC/MASS device, which has been displayed in the Figure (1), the components of Thymol essence, prepared from Nishabour mountains, consist of five main components namely, α -Pinene, α -Terpinene, P-Cymene, γ -Terpinene, and Thymol, according to the table (1), each of which has the percentage of 1.118, 3.831, 25.815, 14.771, and 54.465 respectively in the essence.

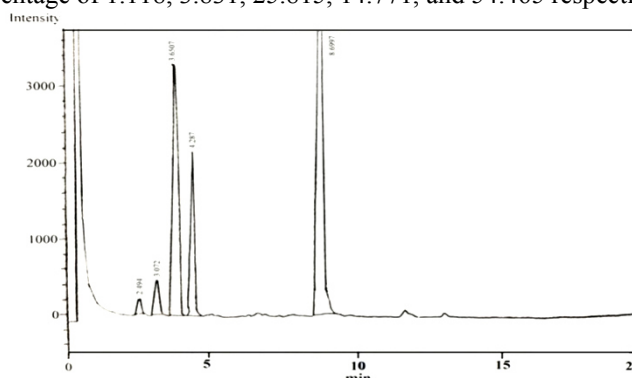

Figure1. Type and the components of Shirazi Thymol essence with GC/MASS device

Table1. The essence components

Number	Component	RI	Percent	Number	Component	RI	Percent
1	Tricyclene	925	0.01	13	Cis-Sabinene Hydrate	1074	0.05
2	α -Pinene	928	1.118	14	Terpinolene	1088	0.05
3	α -Tujene	931	0.02	15	Trans-Sabinene Hydrate	1097	0.07
4	Camphene	945	0.03	16	Borneol	1164	0.09
5	Myrcene	992	0.03	17	Terpinene-4-Ol	1188	0.1
6	α -philladrene	1005	0.04	18	Carvacrol/Methyl Ether	1246	0.1
7	α -Terpinene	1016	3.831	19	Thymol	1297	54.265
8	P-Cymene	1027	25.715	20	β -Caryophyllene	1416	0.2
9	Limonene	1032	0.07	21	Germacrene B	1487	0.2
10	Carvacrol	1035	0.09	22	α -Murolene	1499	0.1
11	1,8-Cineole	1043	0.03	23	β -Bisabolene	1509	0.3
12	γ -Terpinene	1062	14.571	24	δ -Cadinene	1525	0.01
				Total			100

Based on the results of the laboratory analysis by Khorasan Razavi Science & Technology Theme Park, Thymol essence of the Eksir Gol Sorkh Company consisted of 5 main components that according to the table (2) Thymol with 54.46 percent, Para Cymene with 25.81 percent and Gama Trypen with 14.77 percent were the main components.

Table2. The main components of Thymol essence

Number	Time Min	Area	Height	Mole Fraction	Component
1	2.494	1475	212	1.118	α -Pinene
2	3.072	5057	494	3.831	α -Terpinene
3	3.650	34074	3349	25.815	P-Cymene
4	4.287	19497	2205	14.771	γ -Terpinene
5	8.699	71891	6520	54.465	Thymol
Total		131994	12780		

2.1 Simulation of Distillation Column with ASPEN plus Software

Condensation is a way for the separation of the components of a solution that is based on the distribution of the materials between gas and liquid phases; therefore, it is used in the situations that all the components exist in both phases. Instead of entering a new material inside the solution for making the second phase the same as what happens in absorption and discretion processes, in condensation process, the new phase is made because of the evaporation or the condensation of the primary solution. Simulation can be perfectly carried out if all the phase volumes have been adjusted decently, or with consecutive evaporation and condensation. Moreover, both components of the solution can be achieved purely that the advantages of such a separation method is totally obvious. In distillation, the difference between the new phase and the main phase is due to their energy level. It is usually a simple process to decrease or increase the heat; however, the cost of the process should certainly be considered. In distillation, the gas phase, which is obtained from the liquid phase due to the heat, will certainly contain the same components as the liquid does. Since the gas phase is very similar to the liquid phase, the consequent changes in the semi-compound resulted from the distribution of the components between two phases, are not usually a lot [7]. There are two methods for the calculations of the distillation column

- a. The shortcut method
- b. Tray by tray method

In the first method, all trays are considered as the system, and mass and energy balance is written around them. As a result, the material density, pressure, and temperature distribution function, in both liquid and steam phase is obtained. It is fully analyzed in Halland's book; however, it is possible to decrease the volume of the calculation by considering some of the hypotheses, which can be simplified logically. For instance, it is possible to assume light materials in the supply, exist just on top of the distillation column, and heavy materials are just in the bottom of the column. These hypotheses are the basis of the second shortcut method. In this mode, the most part of one of the middle material, exists on the top, and a little of that is in the bottom of the column which is called, Light key. This mode is also popular for one of the other materials; however, for this material, most of that exists in the bottom, and a little exist on top of the column. This material is called, Heavy key. Based on the shortcut method, all the materials, lighter than L.K, exist on top of the column, and all the materials, lighter than H.K, exist in the bottom of the column. This method is approximate, and it is utilized for the estimation of the minimum Reflux Ratio by Underwood method, the minimum tray numbers by Fenske's method, and the

required tray numbers by Gilliland's method. In some references, the shortcut method is called Fenske-Underwood-Gilliland. HYSYS software uses this method, but ASPEN Plus software uses Winn-Underwood-Gilliland, in which the minimum number of trays is calculated by equations (1) & (2).

$$N_{min} = \frac{\ln \left[\frac{x_{LK,D}}{x_{LK,B}} \left(\frac{x_{HK,B}}{x_{HK,D}} \right)^{\theta_{LK}} \right]}{\ln \frac{\beta_{LK}}{HK}} \quad (1)$$

Coefficients β_{LK} & θ_{LK} , are fixed pressure, and these coefficients are obtained according to the amount of K in Light Key & Heavy Key in the low & high temperature. $x_{LK,D}$, is the mole fraction of the light fraction in the top part of the column, and $x_{LK,B}$, is the mole fraction of the light fraction in the bottom of the column; therefore, according to the equation (1), these coefficients are obtained.

$$\frac{\beta_{LK}}{HK} = \frac{K_{LK}}{(K_{HK})^{\theta_{LK}}} \quad (2)$$

2. Simulation

2.1 Simulation of TBP Experiment by ASPEN plus Software

Nowadays, entering designing & simulation pieces of software into the world of industry has made the task of designing and simulation of procedural equipment easy & enjoyable. The combining of theoretical engineering knowledge with the primary computer designing & simulation rules and knowing how to work with the present engineering software is one of the responsibilities of the designing engineers in industry [8]. Offering a pictorial & clear process of designing a distillation column as an example of what happens in designing & engineering units of industry with the powerful ASPEN Plus software; we get more familiar with the characteristics of this software and how to work with [9]. It is worth to mention that this design & calculation is mentioned briefly as a shortcut; however, it is described in details later in this study.

- a. Adding TBP information to the software
- b. Choosing the best equation mode

Since UNIQUAC mode equation is utilized for the complex materials & components, it can be used.

- c. Adding supply stream

If we consider the entrance stream to the column in the temperature of 25°C and the pressure 1atm, we do the simulation.

- d. Determining the suggested components for this set of TBP data

2.2 Simulation of the Separation unit of the Main Components of Thymol Essence by RadFrac Distillation Column in ASPEN plus Software

Distillation column is required for the separation of the main components of Thymol essence. In order to determine the number of the trays, the balance curve is required; although, since the materials are complex and Thymol essence is multi-component, the ordinary calculation is not possible. Because the simulation has not been done in this field, we have to do the simulation by DSTWU distillation column, and utilize the obtained data in RadFrac distillation column; therefore, with putting DSTWU distillation column and adding the data related to the column, the simulation of the column is done to utilize the obtained results from DSTWU column, in the main distillation column. Considering the obtained results from DSTWU columns, the simulation of RadFrac distillation columns can be demonstrated like Figure (2).

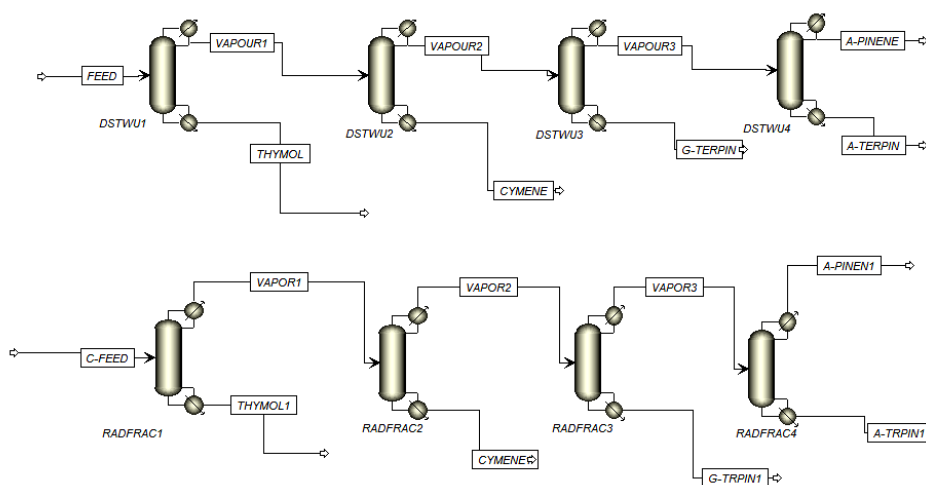

Figure2. Simulation of the separation unit of the natural components of Thymol essence
 For instance, for the separation of Thymol from Cymene, assuming Thymol as the heavy component, which gets

to the amount of 0.01 percent on top of the column and Cymene as the light component exist on top of the column, the reflux amount and the number of trays for separation can be obtained. If separation happens in the pressure of 85 Kpa, we can continue the simulation. In addition to this, the consequent changes due to the pressure change in different pressures will be investigated. If the achieved data from DSTWU column is transferred to RadFrac column, the simulation can be done based on the resulted data. For example, if we are supposed to transfer the resulted data, related to the separation of Thymol, from DSTWU column to RadFrac column, the simulation will be as demonstrated in the following diagram. According to the results obtained from GC experiment for recognizing the components of Thymol essence, demonstrated in table (2), the data related to the recognized materials are inserted in the software, and the separation unit of the main components of the essence is simulated. The mole fraction of the main component of Thymol essence is studied in RadFrac distillation column, based on the changes in different pressures from 44Kpa to 101.3Kpa, and the results are compared in the form of tables and diagrams in the result section.

3. Results and Discussions

Considering the laboratory data, related to TBP that is presented in table (3), the data are added to the software and the suggested materials by software, presented in table (4), has been compared with the results of GC/MASS analysis.

Table3. Experiment Results

Rate of distillation %	Volume of distillation CC	Tc in °C	Tc Out °C	Vapour Temperature °C	Vapour Liquid °C	Time Min	Observation
0	0	21.3	21.3	22	22	0	1
0.028	1	21.4	21.9	160	170	18.28	
0.142	5	21.7	22.5	199	202	31.29	
0.285	10	21.8	22.5	208	214	36.24	
0.428	15	21.8	22.5	220	224	44.17	2
0.571	20	21.9	22.6	232	235	75.41	3,4
0.714	25	21.9	22.7	240	240	81.45	5

Table4. TBP Suggested materials by Software

No.	Suggested materials	Mole Fraction	No.	Suggested materials	Mole Fraction
1	PC37C	0.01066206	9	PC156C	0.00403448
2	PC59C	0.0047157	10	PC173C	0.02992384
3	PC72C	0.00454375	11	PC184C	0.0543245
4	PC86C	0.00448146	12	PC198C	0.05720063
5	PC100C	0.0043795	13	PC212C	0.19075468
6	PC114C	0.00430272	14	PC225C	0.18456668
7	PC128C	0.00413891	15	PC239C	0.30574732
8	PC142C	0.00373637	16	PC252C	0.13248734
Total				100	

The material PC239C with 0.3 percent combination is the highest amount which its boiling point is 239°C. The selection criteria for these materials are the distilled percentage based on the distillation temperature. According to table (4), the suggested material, PC239C with the boiling point of 239°C and molecular mass of 171 is almost similar to the characteristics of Thymol material.

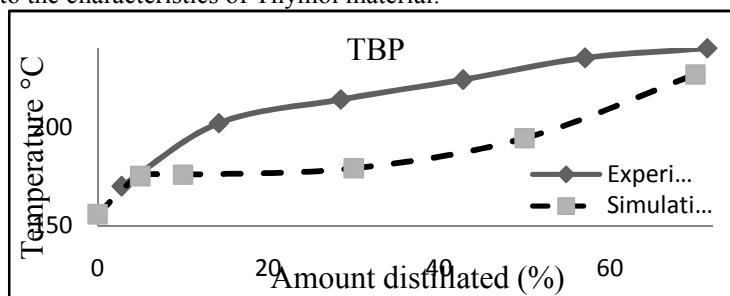

Figure3. Temperature changes based on the distillation percentage in two modes of laboratory and simulation, by ASPEN plus software

In Figure (3) the results of the boiling point experiment, is presented, and it is shown by a solid line while the

results of the simulation is shown by a dotted line. These results have been compared in the Figure (3) that according to the diagram we can conclude that ASPEN Plus software is not decently programmed for these complex combinations.

3.1 Results of the simulation of RadFrac distillation columns

Table5. Results of the simulation of the first distillation column

Mole Fraction	Feed	Distill	bottom
CYMENE	0.25815	0.53144	0.05198
A-TERPINE	0.0383	0.08907	1.96E-16
G-TERPINE	0.1477	0.34349	4.05E-14
A-PINENE	0.0112	0.02605	2.75E-19
THYMOL	0.54465	0.00995	0.94802
Total	1.0000	1.0000	1.0000

According to the table (5), the first distillation column, could separate 94 percent of Thymol from other compounds.

Table6. Results of the simulation of the second distillation column

Mole Fraction	Feed	Distill	bottom
CYMENE	0.53144	0.00029	0.97132
A-TERPINE	0.08907	0.1961	0.00043
G-TERPINE	0.34349	0.74612	0.01005
A-PINENE	0.02605	0.05749	9.45E-06
THYMOL	0.00995	2.34E-06	0.01819
Total	1.0000	1.0000	1.0000

According to the table (6), the second distillation column could separate 97 percent of Cymene from other compounds.

Table7. Results of the simulation of the third distillation column

Mole Fraction	Feed	Distill	Bottom
CYMENE	0.00029	6.72E-16	0.00041
A-TERPINE	0.1961	0.55569	0.04199
G-TERPINE	0.74612	0.2527	0.95759
A-PINENE	0.05749	0.1916	7.07E-06
THYMOL	2.34E-06	8.80E-19	3.34E-06
Total	1.0000	1.0000	1.0000

According to the table (7), the third distillation column could separate 95 percent of γ -Terpinene from other compounds.

Table8. Results of the simulation of the fourth distillation column

Mole Frac	Feed	Distill	bottom
CYMENE	6.72E-16	0	0
A-TERPIN	0.55569	0.01596	0.68147
G-TERPIN	0.2527	4.68E-05	0.31158
A-PINENE	0.1916	0.98399	0.00694
THYMOL	8.80E-19	0	0
Total	1.0000	1.0000	1.0000

According to the table (8), the fourth distillation column could separate 98 percent of α -Terpinene from other compounds.

3.2 Results from Pressure Change in Distillation Column

In Figure (4), Thymol mole fraction in the first RadFrac distillation column is investigated based on the pressure change from 44KPa to 101.3KPa.

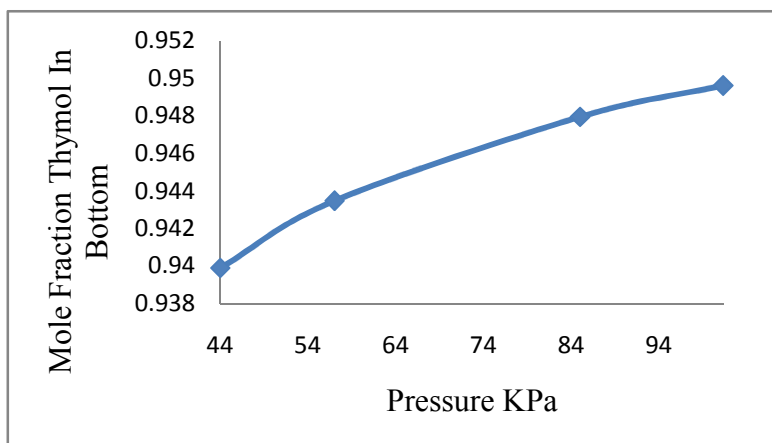

Figure4. Thymol mole fraction changes, based on the pressure increase in the first distillation column
As it is shown in Figure (4), Thymol mole fraction in the product of the bottom of the column increases from 0.9496 to 0.9993 according to the increase of the total pressure of the distillation column from 44 KPa to 101.3 KPa.

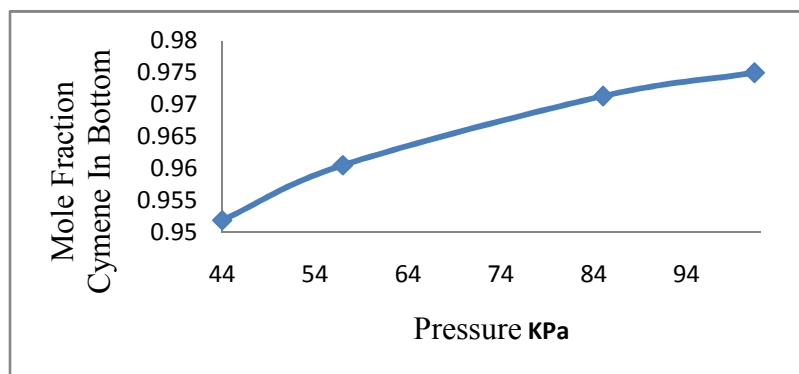

Figure5. Cymene mole fraction changes, based on the pressure increase in the second distillation column
As it is shown in Figure (5), Cymene mole fraction in the product of the bottom of the column increases from 0.951 to 0.974 according to the increase of the total pressure of the distillation column from 44 Kpa to 101.3 Kpa. According to the Figure (5), Cymene mole fraction in the second RadFrac distillation column is investigated based on the pressure change from 44 KPa to 101.3 KPa.

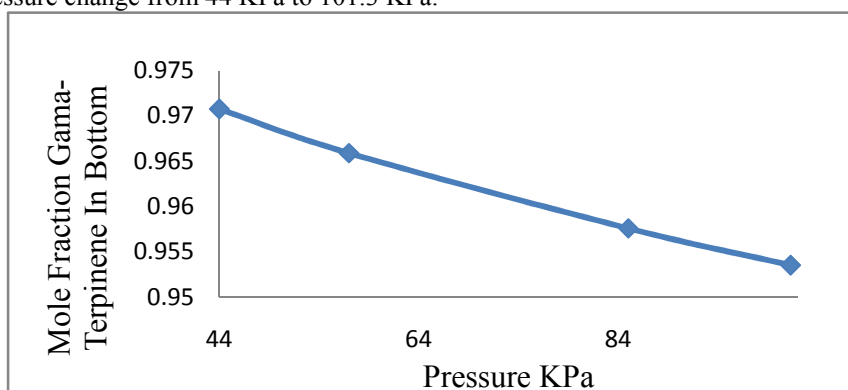

Figure6. γ -Terpinene mole fraction changes, based on the pressure increase in the third distillation column
As it is shown in Figure (6), γ -Terpinene mole fraction in the product of the bottom of the column decreases from 0.970 to 0.953, according to the increase of the total pressure of the distillation column from 44 KPa to 101.3 KPa. In Figure (6), γ -Terpinene mole fraction in the third RadFrac distillation column is investigated based on the pressure change from 44 KPa to 101.3 KPa.

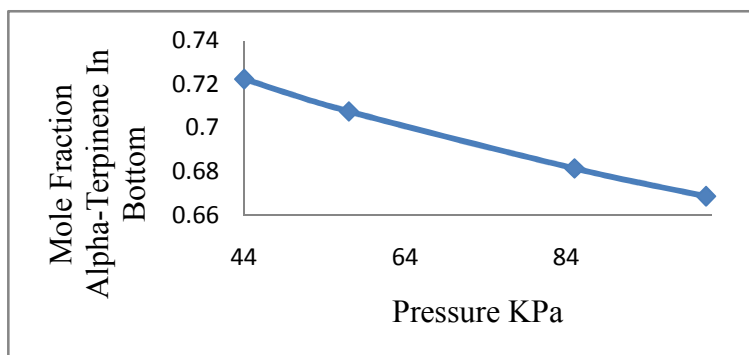

Figure7. α -Terpinene mole fraction changes, based on the pressure increase in the fourth distillation column. As it is shown in Figure (7), α -Terpinene mole fraction in the product of the bottom of the column decreases from 0.722 to 0.688 according to the increase of the total pressure of the distillation column from 44 KPa to 101.3 KPa.

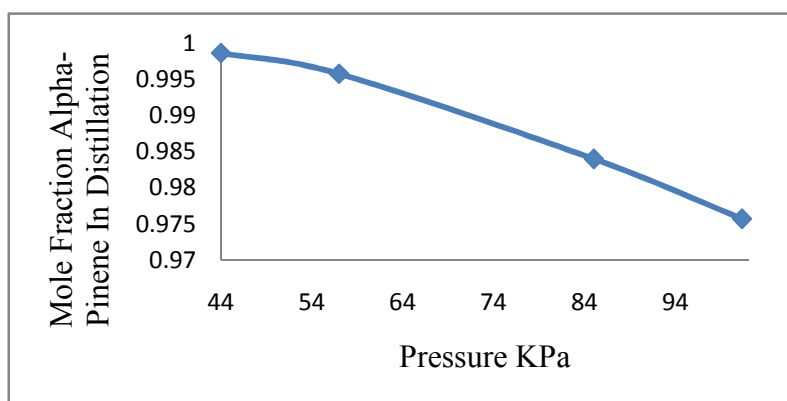

Figure8. α -Pinene mole fraction changes, based on the pressure increase in the fourth distillation column. As it is shown in Figure (8), α -Pinene mole fraction in the product of the top of the column decreases from 0.988 to 0.975 according to the increase of the total pressure of the distillation column from 44 KPa to 101.3 KPa.

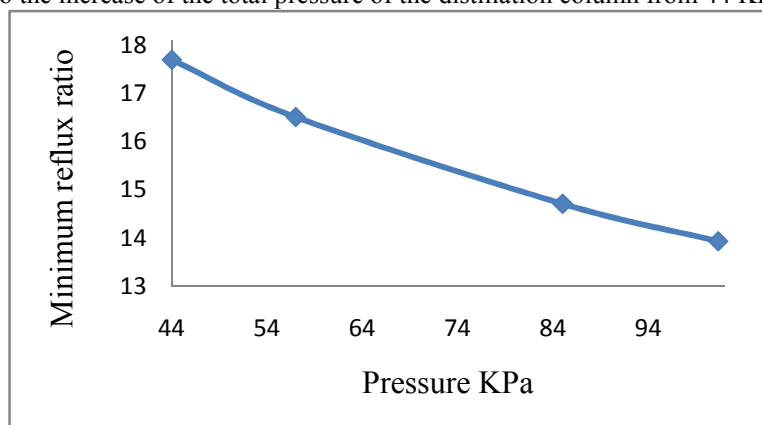

Figure9. Minimum changes of the return reflux, based on the pressure increase in the distillation column. As it is shown in Figure (9), the minimum return reflux decreases from 17.7 to 13.93 according to the increase of the total pressure of the distillation column from 44 KPa to 101.3 KPa.

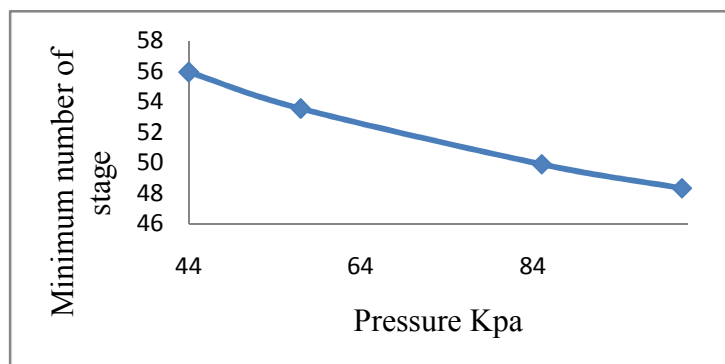

Figure10. Minimum changes of the number of trays, based on the pressure increase in the distillation column
As it is shown in Figure (10), the minimum number of trays in the first distillation column decreases from 55.84 to 48.33 according to the increase of the total pressure of the distillation column from 44 KPa to 101.3 KPa.

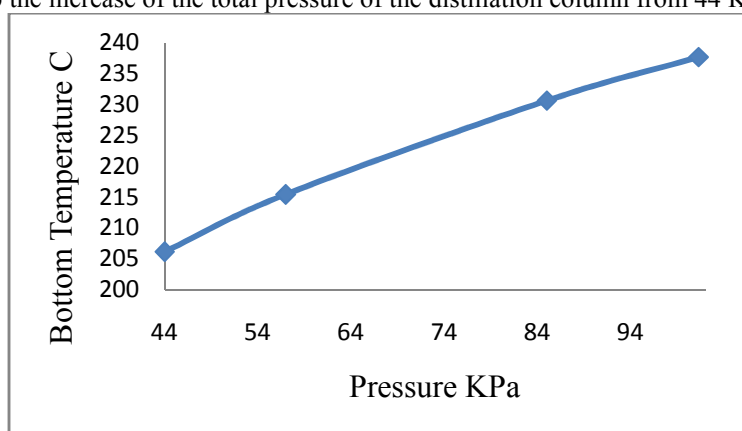

Figure11. Temperature changes in the bottom of the column, based on the pressure increase in the distillation column

As it is shown in Figure (11), the temperature of the bottom of the first distillation column increases from 206°C to 237°C according to the increase of the total pressure of the distillation column from 44 KPa to 101.3 KPa.

4. References

1. Jam Zad, Thymus. Research Institute of Forests and Rangelands, 1373, 91: 1-17
2. Akbarinia, A., Sharifi-Ashabadi, A. and Sefidkon, F., 2009. Influence of harvest dynamics on herb and oil yield of *Thymus kotschyanus* and *Thymus daenensis* cultivated at two Sites. International workshop on medicinal and aromatic plant, Acta Horticulture, 786: 229-234.
3. Beigi, R., O, Production and processing of medicinal plants. Publication of Astan Quds Razavi, 1379; 88-99.
4. Askari, F., 2003, Essential oil composition of *Thymus daenensis* Celak. from Iran. Journal of Essential oil Bearing Plants, 6(3):123-125.
5. Naghdi, Badi, H., Darab, H., Yazdani, D., Sajedi, M. and Nazari, F., 2004. Effects of spacing and harvesting time on herbage yield and quality/quantity of oil in thyme, *Thymus vulgaris* L. Industrial crops and products, 19(3): 231-238.
6. Nik Avar, F. persuasive. Review components of thyme essential oil world wages its flowering branches. Journal of Medicinal Herbs, 1383, No. 13: 50-45
7. Winn, F. W., *the Petroleum Refiner*, 37(5), p. 216, (1958).
8. Juma Haydary, Tomáš Pavlík” Steady-State and dynamic simulation of Crude oil distillation using ASPEN Plus and ASPEN DYNAMICS” *Petroleum & Coal* 51(2) 100-109 (2009)
9. Luyben, William L, *Distillation Design and Control Using Aspen Simulation*, John Wiley & Sons, New York, 2006