

# Shear Capacity of Steel Fiber Non-Metallic (GFRP) Reinforced Concrete Beams Strengthened in Shear Using CFRP Laminates

Ass.Prof. Dr. Mu'taz Kadhim Medhlom,

. Civil Engineering Department, Collage of Engineering, Al-Mustansiriyah University, Baghdad, Iraq.

## Abstract:

A total of ten large –scale concrete beams were constructed and tested under four–point monotonic loading until failure .Nine of these beams were longitudinally reinforced with glass fiber reinforced polymer (GFRP) strengthened with externally bonded CFRP laminate while the remain beam was reinforced with conventional steel bars with web reinforcement as control specimen. To examine the shear behavior, the main parameters investigated in this study included volume fraction of fiber (0, 0.50 , 1.0) % reinforcement and wrapped with two different configurations of CFRP laminate (U-Jacket and sheets are side bonded) were examined .The test results were compared with recommended design code .The results are summarized and analyzed in detail in the paper in terms of shear capacity, cracking pattern and shear resisting contribution of FRP and steel fiber .

**Keywords :** Beams ,Shear, Steel fiber , GFRP bars ,Strengthening by CFRP .

## 1. Introduction

Due to their lightweight ,high tensile strength ,and ease to install on irregular surface ,the use of FRP system for the repair and strengthening of RC structures has become an accepted practice within civil engineering community .FRP system used for strengthening of RC structures mainly consist of two different methods, the externally bonded laminates and near –surface mounted bars .These systems may contain either carbon fiber (CFRP) or glass fiber (GFRP) reinforced polymers .For shear strengthening ,generally the externally bounded CFRP systems are used .

Although comprehensive standard specifications exist for all commonly used traditional constructional materials, the design specifications for FRP use in strengthening ,especially for shear strengthening ,are still underway for full development .Furthermore, the available results are scare and sometimes controversial.

Triantafillou,T.C.,1997,[1], base on the experimental results , noted that CFRP sheets used for strengthening rupture at stress levels below their ultimate strength due to stress concentrations in the sheet and observed the effective strain to be a function of the axial rigidity of CFRP sheet .

Gustafsson and Noghabai ,(1998) ,[2], investigate if steel fibers can replace stirrups as shear reinforcement in high strength concrete beams . Analysis of the results indicates some favourable aspects concerning the use of steel fibers as shear reinforcement .

Chaallat et al., 2002,[3], are reported ,the contribution of externally bonded FRP laminates to the shear resistance of strengthened structural members to be less for members with high transverse reinforcement ratio than ones with low transverse ratio .

Choo et al. (2002),[4], The behavior of concrete beams wrapped with four different configurations of CFRP fabric is experimentally investigated .Results of the testing shown that shear strength is increased up to 33% on concrete beams wrapped with CFRP fabric at an angle of  $45^{\circ}$  to the longitudinal axis of the beam .

Kwak et al. (2002),[5], The results demonstrated that the nominal stress at shear cracking and the ultimate shear strength increasing fiber volume ,decreasing shear span ,depth ratio and increasing concrete compressive strength .As the fiber content increased the failure mode changed from shear to flexure .

Ahmed & Hassan ,(2003) ,[6] , concluded that the effectiveness of FRP strengthening to shear contribution is depended on the amount of internal shear reinforcement , it appear that the composites are less effective when beams are heavily reinforced with internal shear reinforced .

Bousselham ,A. and Chaalal ,O., 2004 . [7] , recent studies revealed the fact that externally applied FRP laminates contribute more to the shear resistance of slender beams .

Mattat et al. (2006),[8], The preliminary results are reported that indicate a decrease in concrete shear strength attributable to size effect ,which is offset by an implicit under strength factor in the current ACI 440 design formula .

Bousselham and Chaallal ,(2006 a) [9] ,show that a higher concrete strength will delay failure by debonding .A low concrete strength will inhibit early crushing of concrete in the compression zone or in the diagonal struts ,but

it will decrease the bond strength at the FRP-concrete interface .

Bousselham and Chaallal (2006 b) [10] ,studied the influence of the a/d ratio ,the results indicated a larger gain in shear resistance due to FRP for slender beams than for deep beams ,probably because of the arch action exhibited by deep beams.

Concrete strength influence the performance of shear strengthening with FRP because it influences the bonding performance at the FRP-concrete interface and the failure mode .

Leung et al. (2007) ,[11] ,the results of tests on RC beams strengthened in shear with externally bonded FRP ,showed a tendency for a decrease in the gain of shear resistance due to FRP as the height of the specimen increased .

Jin et al. (2009),[12] , This study will discuss of concrete shear contribution of the lightweight concrete beam reinforced with FRP bar, with varying concrete compressive strengths and flexural reinforcement ratios .The test result gives better results than the ones predicted by the ACI 440.1R-06 and ISIS-MO3-01 codes .

Bukhari et al. (2010) ,[13] , reviews existing design guidelines for strengthening beams in shear with carbon fiber reinforced polymer (CFRP) sheets and proposes a methodology for strengthening beams with FRP that is consistent with Eurocode 2 .

NCHRP Report , 2011 .[14] , the configuration of the FRP system affects the failure mode of shear strengthening members .Based on an extensive review of collected experimental data .FRP debonding almost never occurs in beams retrofitted with complete wrap and U-wraps with anchorage system .

Noor Azline et al. ,2013 .[15] , presents test results of beams longitudinally reinforced either by steel or glass FRP bars .Due to low modulus elasticity of FRP ,it was found that lesser shear strength results compared to beams reinforced with steel bars .

Belarbi A. & Acun B. (2013) .[16] , study several analytical models have been proposed for predicting the shear contribution of externally bounded FRP ,due to insufficient experimental data ,these models were not calibrated accurately and hence produced diverse or in many cases contradictory estimates .As the number experimental results increase ,these models can be recalibrated to produce more reliable results .

Alferjani et al. ,2013 ,[17], attempts to address an important practical issue that is encountered in shear strengthening of beams with carbon fiber reinforced polymer laminate. This paper also proposes a simple method of applying fiber reinforced polymer for strengthening the beam with carbon fiber reinforced polymer.

Shamsher B.S.(2013) ,[18], investigation addresses the shear strengthening of deficient reinforced concrete (RC) beams using carbon fiber-reinforced polymer (CFRP) sheets . The effect of the pattern and orientation of the strengthening fabric on the shear capacity of the strengthened beams were examined. A design example for shear strengthening shows that the design equations available in the literature underestimate the actual shear strength of the beams .

An attempt has hence been made to provide an effective method of strengthening beams by introducing short steel fibers and bonding of CFRP laminates to concrete beams without steel stirrups .Three types of concrete beams were casted, with conventional RC beam for reference , Dramix steel fiber reinforced concrete beams with three volume fractions (0 ,0.5 & 1.0) % and each volume of steel fiber with three beams were strengthening with two different configuration , see Table 5 .

## 2. Experimental Program

### 2.1. Material Properties

The specified design strength of concrete is 30 MPa at 28 days .Ordinary Portland Cement (ASTM Type I) was used in casting all the specimens .The specific gravity of fine aggregate and coarse aggregate is 2.28 and 2.65 respectively .The properties of short steel fibers are presented in Table 1 and typical steel fiber with hooked end .

Table 1 :Properties of steel fibers\*

Properties	Specification
Length	30 mm
Shape	Hooked at ends
Diameter	0.375
Aspect Ratio	80
Density	7860
Young s' Ratio	$200 \times 10^3$
Tensile Strength	2000 MPa
Poisson s' Ratio	0.28

- According to the certified of conformity

Based on several trial mixes ,one NC mix and two mixes (NC-05 and NC-1) that differ from each other only in volumetric steel fibers ratio were adopted in this work as shown in Table 2 .

Table 2 gives the final quantities of materials used in preparation of normal and fiber concrete per cubic meter adopted in this study .Table 3 shows test results of mechanical properties for three mixes .Each value presented in this table represents the average value .

Table 2: Concrete mix design

Mix name	Cement (kg)	Water (liter)	Sand (kg)	Gravel (kg)	Steel fiber (kg)
NC	400	200	800	1200	0
NC-05	400	200	800	1200	39.25
NC-1	400	200	800	1200	78.50

Table 3: Test results of mechanical properties

Mix Name	$f_c'$ (MPa)	$f_t$ (MPa)	$f_r$ (MPa)
NC	32	3.0	4.41
NC-05	35	3.9	6.32
NC-1	37.5	4.5	7.02

## 2-2 Description of Test Specimens

Ten beams specimens ,purposely design to fail by shear strength ,were tested with a static four-point loading scheme .The (150×200×2000) mm size ,nine beams were cast in three groups with three beams in each , with three different amount of short steel fiber, (Group GFR0) ,without steel fiber , (Group GFR05) with 0.5% volume of steel fiber and (Group GFR1) , with steel fiber of 1% volume .In this way tensile steel in beams of groups GFR0 , GFR05 and GFR1 is the same used 3Nos of 12 mm glass fiber reinforced polymer (GFRP) without shear reinforcement .Another beam (RCB0) was normal concrete reinforced with 3Nos of 12 mm conventional steel bar with 8 mm diameter two-legged stirrups @ 75 mm c/c spacing as control specimen . The properties of reinforcement bar are summarized in Table 4 .

Table 4 : Properties of reinforcement bars

Bar type	Diameter mm	Tensile strength MPa	Modulus of elasticity MPa	Elongation %
GFRP	12	1200	55	2.2
Steel	12	510	205	15
Steel	8	430	160	18

The beams in each group were strengthened by CFRP laminate with two different configurations .One beams in each group was kept un strengthened as control beam. Typical geometry and reinforced detail of beams are given in Table 5 and figure 1.

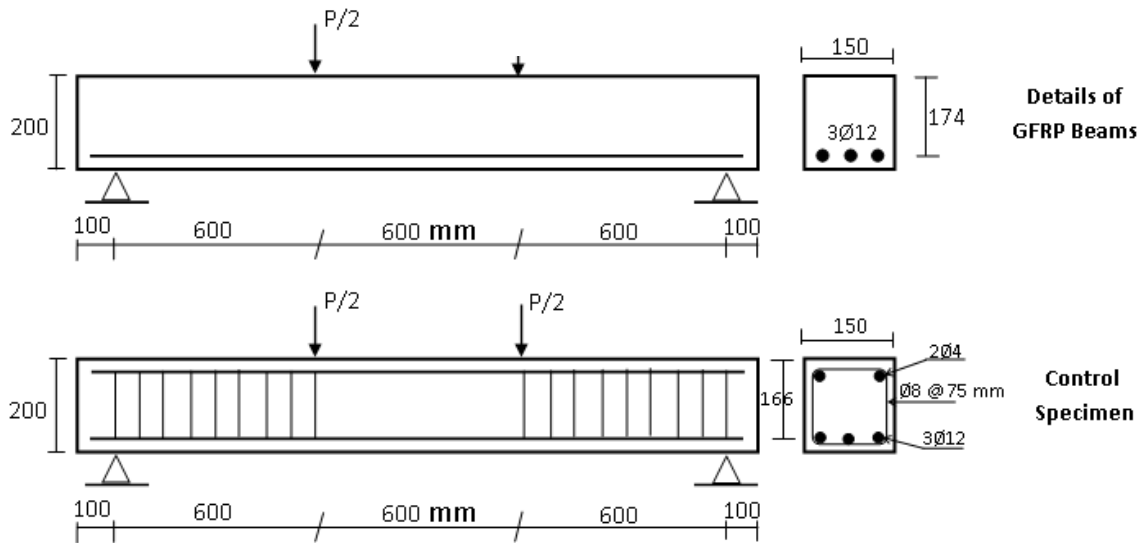

Figure 1 :Typical Geometry and Reinforcement Details for Beams

Table 5: Characteristics of beams tested and parameters investigated

Groups	Beam symbols	Steel fiber %	Strengthening application	Strengthening pattern
GFR0	GFR0-N	0	None / As built	
	GFR0-S1	0	U - Jacketing	
	GFR0-S2	0	Side Bounding - Sheets	
GFR05	GFR05-N	0.50	None / As built	
	GFR05-S1	0.50	U - Jacketing	
	GFR05-S2	0.50	Side Bounding - Sheets	
GFR1	GFR1-N	1.0	None / As built	
	GFR1-S1	1.0	U - Jacketing	
	GFR1-S2	1.0	Side Bounding - Sheets	
RCB0	RCB-N	0	None	

### 2-3 Strengthening of Test Specimens

Strengthening of test specimens has been carried out .In all six RC beams test specimens , the two beams from each group GFR0, GFR05 and GFR1 were shear strengthened .

Nitowrap FRC ,a carbon fiber wrapping system from Fosroc chemicals, is extremely easy to handle and apply with no noise and minimal site equipment necessary .In this system Nitowrap FRC fabric was used in conjunction with an epoxy sealer cum primer .The mechanical properties were taken from manufacturing

specifications which are given in Table 6 .

Table (6): Technical properties of CFRP

Properties	Tensile strength kgf/cm <sup>2</sup>	E – Modulus kgf/cm <sup>2</sup>	Adhesion to concrete kgf/cm <sup>2</sup>	Width (mm)	Thickness (mm)	Dry time @ 20 <sup>0</sup> C
Nitowrap	35,500	2.35×10 <sup>6</sup>	> 27.0	300	0.167	10 hours

#### 2-4 Strengthening Configurations

Strengthening of the beams begun after the beams had sufficient cured ,and carried out as per the FRP manufacturer s' instructions .The CFRP was ready for application as the CFRP was cut to desired size and the concrete surface was prepared. The CFRP strips were externally bonded in two configurations by a (i) U-Jacketing strips at two vertical sides , and tension bottom face with width and spacing 80 mm c/c and (ii) Mat only at two vertical sides of shear region ,as shown in Table 5 .

#### 2-5 Testing Arrangement

All the beams were tested with the same test setup .A 300 ton hydraulic testing machine (MFL) was used for testing of beams in increment of 2.5 kN until failure . Beams were simply supported over a span of 1800 mm .The arrangement is shown in Figure (2) .Dial gauges 0.01 mm accuracy were used to measure deflection at loading points and at mid span .



Figure : 2 : Test Machine

### 3- Test Results and Discussion

#### 3-1 General

Prior to discussing the test results, it is helpful to discuss the general behavior of beams failing in shear .Figure 3 shows the development of the crack pattern which leads eventually to failure in several modes .The type of failure that occurs depends mainly on percentage of steel fiber and phase of strengthening by CFRP laminate .Table 7 ,summarized the experimental results of all the tested beams and their deflections with the failure mode .

Table 7 :Summary of tested beams results

Beam symbols	Load at first Crack (kN)	Ultimate load (kN)	Experimental maximum deflection- (mm)	Failure mode
GFR0				
GFR0-N	15	30	5.85	Diagonal Tension
GFR0-S1	30	80	4.15	Diagonal Tension
GFR0-S2	35	95.5	3.3	Shear-Compression
GFR05				
GFR05-N	20	42.5	5.4	Shear-Compression
GFR05-S1	35	92.5	3.8	Shear-Compression
GFR05-S2	40	112.5	2.91	Flexure
GFR1				
GFR1-N	25	57.5	5.0	Shear-Compression
GFR1-S1	40	105	3.51	Shear-Compression
GFR1-S2	45	125	2.63	Flexure
Control Specimen				
RCB0	28	100	15.5	Flexure

### 3-2 Crack Pattern Development and General Behavior

#### 3-2-1 Failure Pattern of Control Beam

The beam was so design that it fails by flexure .The beam was tested up to 100 kN with further increase in the load ,regularly spaced flexure and shear cracks were observed and they extended the bottom of the specimen towards the top fiber as shown in Figure 3.

#### 3-2-2 Failure Pattern for Strengthening Beams Reinforced with Steel Fiber

From the mode of failure illustrated in Figure 3 and Table 7 ,there are three types of failure .Diagonal tension failure occurs in beams without steel fiber , shear- compression failure occurs in beams with steel fiber and flexure failure occur only in beams GFR05-S2 and GFR1-S2 .





Figure 3: Typical Crack Patterns for Specimens

The beams in group GFR0 , the crack pattern follow curved paths in the direction towards the compression zone .Finally , failure occurs quit suddenly ,extends rapidly through the compression zone .All the beams failed in diagonal tension .However, the ultimate loads were higher than the inclined cracking loads by an amount varying from 100% , 166% and 173% for beams GFR0-N ,GFR0-S1 and GFR0-S2 respectively .

The load carrying capacity of beams GFR0-S1 and GFR0-S2 were decreased by 20% and 4.5% respectively when compared with control beam.

Figure 3: Typical Crack Patterns for Specimens

All the beams in groups GFR05 and GFR1 exhibit the same behavior and failed in shear-compression failure except the beams GFR05-N2 and GFR1-N2 failed in flexure. With further increase in the load ,regularly spaced flexure and shear cracks were observed and they extended from the bottom of the specimen towards the top fiber as shown in Figure 3 .

The beams were reinforced with steel fiber and strengthened with one layer of CFRP laminate. The ultimate loads were higher than the inclined cracking varied from 112 and 164.3% for beams GFR05-N and GFR05-S1 to 130% and 162.5% for beams GFR1-N and GFR1-S1 respectively .The combination of steel fiber and strengthened by CFRP laminate changes the mode of failure to mainly ductile flexural failure evident in beams GFR05-S2 and GFR1-S2 .

### 3-3 Effect of Steel Fiber on Behavior of Beams

From the results it is quite clear that the ultimate shear capacity were positively affected by steel fibers. The effect of steel fibers on cracking shear was smaller than the effect on shear strength as illustrated in Table 7 .The effect of fiber content on strength of the GFRP reinforced concrete beams with externally bonded CFRP laminate are illustrated in Figure 4 .

The beams without strengthening, the steel fiber volume increase to 0.50 and 1.0% the increase in cracking and ultimate shear strength range from 33.334 to 66.667 % and 41.667 to 91.667 % respectively of the cracking and ultimate shear strength of similar beams without fibers. Figure 5 ,shows load – deflection curve for beams without strengthening .The decrease in mid-span deflection when steel fiber increase to 0.5 to 1.0% range 7 to 14.5% respectively .

Ditto, for the beams strengthening with U-Jacketing and side bond sheet ,the summary of increase in cracking and ultimate shear strength and decrease in mid-span deflection when steel fiber increase 0.5 and 1.0 % as shown in Table 8 and Figure 6 and Figure 7 .

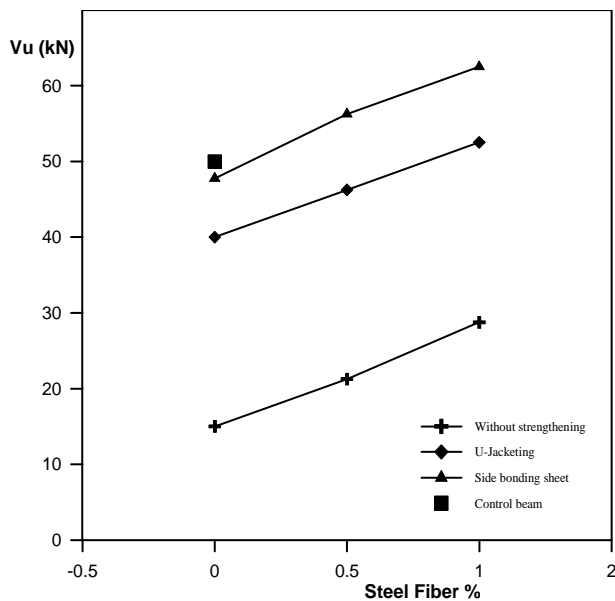

Figure 4 : Effect of Steel Fiber on Behavior of Beams Strengthening with CFRP Laminate

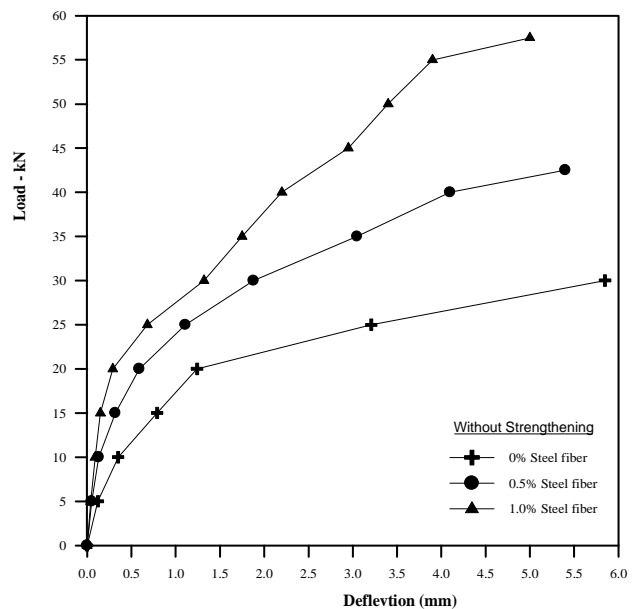

Figure 5 : Load – Deflection Curve for Beams Without Strengthening



Table 8 : Effect of fiber content on  $V_{cr}$ ,  $V_u$  and deflection

Type of strengthening	Beams symbol	Increase $V_{cr}$ %	Increase $V_u$ %	Decrease deflection %
U-Jacket	GFR05-S1	16.667	15.6	8.43
	GFR1-S1	33.334	31.25	15.42
Side Bonding Sheet	GFR05-S2	14.3	17.85	11.81
	GFR1-S2	28.57	30.89	20.3

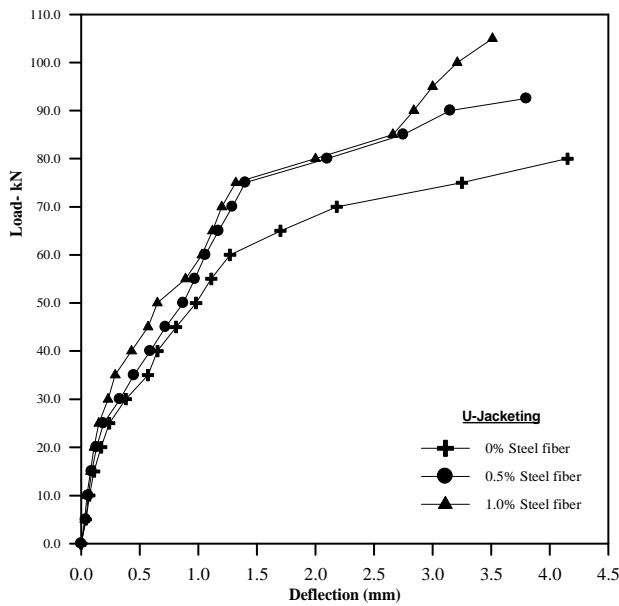

Figure 6 : Load – Deflection Curve for Beams With U-Jacketing Strengthening

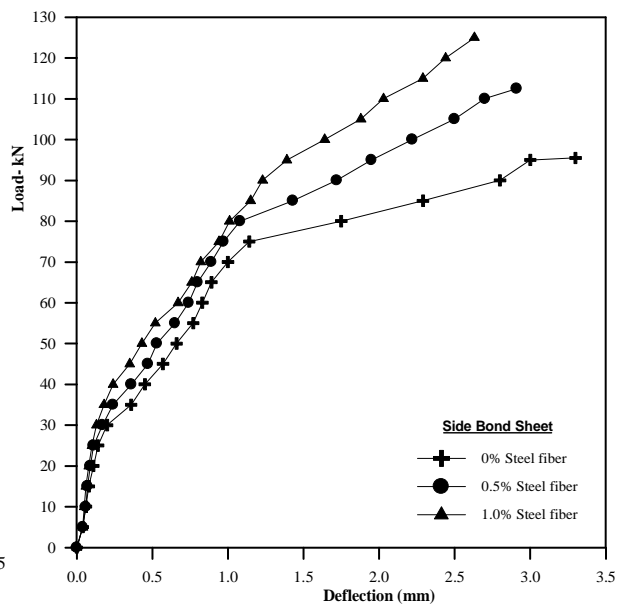

Figure 7 : Load – Deflection Curve for Beams With Side Bond Sheet Strengthening

### 3-4 Effect of Strengthening on Behavior of Beams

The summary of the test results for all the beam specimens are detailed in Table 7 and load mid-span deflection curves for all specimens are shown in Figure 8 .It can be noticed that, the initial slope of all curves remains identical .This means that the provided external shear reinforcement did not increase the initial flexural stiffness of the beam .The mid-span deflection of the strengthened specimen at ultimate was decrease about 29 to 45% for the deflection of control specimen .

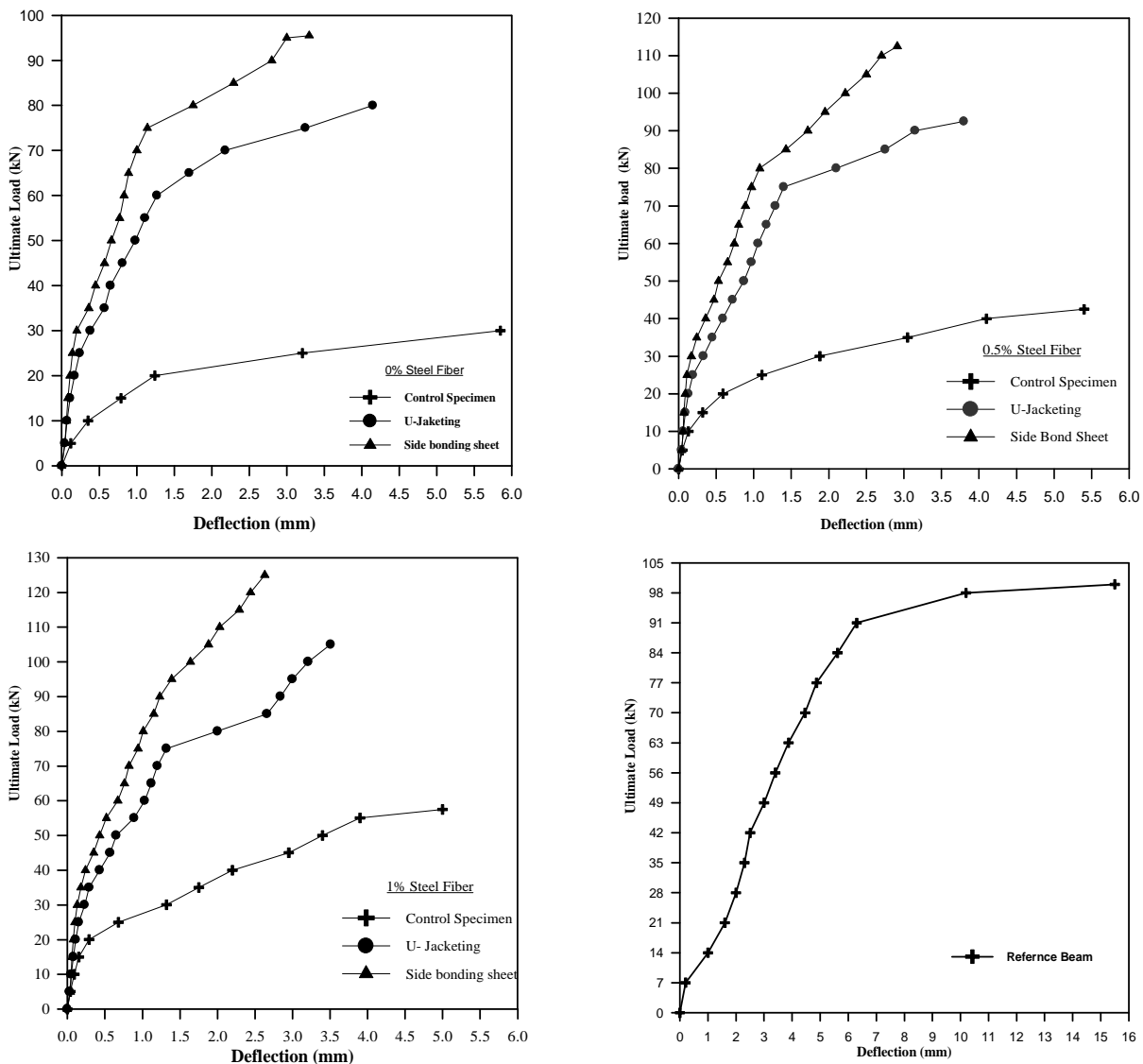

Figure 8 : Load – Deflection Curve for Beams Strengthened with CFRP Laminate

**Series GFR0:** For the specimens tested in this series (0% steel fiber), increase in shear strength of 166.667 to 218.333% were achieved .The shear strength of beam (GFR0-S2) is equivalent to reference beam (RCB0) in shear strength but reference beam was more ductility than the specimens in this series .

**Series GFR05:** In this test series (0.5% steel fiber), increase in shear strength ranged from 117.65 to 164.70% for beam without strengthened .The shear resistance is greater for the (GFR05-S2) specimen than for the reference beam (RCB0) 12.5% gain .

**Series GFR1:** In this test series (1% steel fiber), increase in shear strength range from 82.6 to 117.4% were achieved .The test results indicated that contribution of CFRP benefits the shear capacity for beams without shear reinforcement at a greater degree than for reference specimen with adequate shear reinforcement .

#### 4- Comparison of Test Results with Shear Design Equations

In order to verify the design provision in the codes ,the test results were compared with recommended design code . The nominal shear strength of a concrete beam wrapped with FRP fabric can be calculate as :

$$V_n = V_c + V_s + V_f \quad \dots\dots (1)$$

The shear resistance attributed to concrete ,  $V_c$  of members reinforced with FRP bars as flexural reinforcement is calculated according to some theoretical models ,as shown below in Table 9 .

Table 9 :Shear design equations for FRP-reinforced concrete beams

Designation	Equations
ACI 440.1R-06 Design Guidelines [19]	$V_c = \frac{2}{5} k \sqrt{f'c} bw.d \dots \dots (2)$ $k = \sqrt{2\rho_f \cdot n_f + (\rho_f \cdot n_f)^2} - \rho_f \cdot n_f \quad \text{and} \quad n_f = E_f / E_c,$
JSCE (1997) Design Recommendations [20]	$V_c = 0.2 \left( 100 \rho_f \frac{E_f}{E_s} \right)^{1/3} \left( \frac{1000}{d} \right)^{1/4} (f'c)^{1/3} bw.d \dots (3)$ <p>Where :</p> $\left( \frac{1000}{d} \right)^{1/4} \leq 1.5$ $\left( 100 \rho_f \frac{E_f}{E_s} \right)^{1/3} \leq 1.5$ $(f'c)^{1/3} \leq 3.6$
ISIS Canada – 01 [21]	$V_c = 0.2 \left( f'c \cdot \frac{E_f}{E_s} \right)^{1/2} bw.d \dots \dots (4)$ <p>For <math>d \leq 300</math> mm</p>

In this section also some theoretical models ,see Table 10 ,for shear prediction of fiber reinforced concrete beams ,  $V_c$  .

Table 10 : Equations for estimating the shear capacity of steel fiber reinforced concrete beams

Designation	Equations
Narayanan et al. [22]	$V_c = \left[ 0.24 \left( \frac{f'c}{20 - \sqrt{F_f}} + 0.7 + \sqrt{F_f} \right) + 80 \rho_s \frac{d}{a} + 1.7 F_f \right] bw.d \dots \dots (5)$
Ashour [23]	$V_c = \left[ (0.7 \sqrt{f'c} + 7 \sqrt{F_f}) \frac{d}{a} + 17.2 \rho_s \frac{d}{a} \right] bw.d \dots \dots (6)$

The shear strength of FRP fabric  $V_f$  is calculated using the equation proposed by Khalifa et el [24] as;

$$V_f = \frac{A_f \cdot f_{fe} (\sin\beta + \cos\beta) \cdot d_f}{S_p} \dots \dots (7)$$

The effective stress  $f_{fe}$  of FRP fabric in Eqn. (7) is calculated using the equation proposed by Khalifa et el as ;

$$f_{fe} = R \cdot f_{pu} \dots \dots (8)$$

The value of factor R is calculated using three equations as shown below and chosen the lowest value .

- Factor R based on effective stress (proposed by Khalifa et el) as ;

$$R = 0.5622 (\rho_f \cdot E_f)^2 - 1.2188 (\rho_f \cdot E_f) + 0.778 \dots \dots (9)$$

- Factor R based on bond failure mechanism (proposed by Maeda et el 1997 [25]) as ;

$$R = \frac{0.0042 (f'c)^{2/3} \cdot W_{fe}}{(E_f \cdot t_f)^{0.58} \cdot \epsilon_f \cdot d_f} \dots \dots (10)$$

Where :

$$W_{fe} = d_f - L_e$$

$$L_e = \frac{461.3}{(E_f \cdot t_f)^{0.58}}$$

- Factor R based on limit strain (proposed by Replark system 2000 [26] ) as ;

$$R = \frac{0.004}{\epsilon_f} \dots \dots \dots (11)$$

It can be noticed from Table (11) that the mean of  $V_{ex}/V_n$  obtain by JSCE-97 is approximately the same as that from the existing experimental data ( $\frac{V_{ex}}{V_n} = 1.123$ ) . However ,JSCE-97, gives more conservative predictions for shear strength of beams reinforced with GFRP bars and strengthening using CFRP laminate without steel fibers .

Figure 9 also shown the performance of the test results with those provided by commonly shear design standards .

The ratio of experimentally measured to analytically calculated shear strength  $\frac{V_{ex}}{V_n}$  for all beams is shown in figure .Shear design equations of JSCE-97 and ISIS-01 provides better results than that of ACI440-06 for beams without steel fibers .The equations suggested to apply for steel fiber reinforced concrete beams shows that there are overestimate the shear capacity .This development is quite dangerous considering that beams reinforced with GFRP bars and externally strengthening in shear using CFRP laminate .

Table 11 : Comparison of experimental results with other design codes

Specimens	$V_{ex}$ . kN	$V_f$ . kN	$V_c$ - for beams without steel fibers									$V_c$ - for beams with steel fibers					
			ACI 440-06			JSCE-1997			ISIS Canad			Narayan at el			Ashour at el		
			$V_c$	$V_n$	$\frac{V_{ex}}{V_n}$	$V_c$	$V_n$	$\frac{V_{ex}}{V_n}$	$V_c$	$V_n$	$\frac{V_{ex}}{V_n}$	$V_c$	$V_n$	$\frac{V_{ex}}{V_n}$	$V_c$	$V_n$	$\frac{V_{ex}}{V_n}$
GFR0-N	15	---	10.5 3	10. 53	1.42 4	16.2	16.2	0.92 5	14.2	14.2	1.05						
GFR0-S1	40	13.5 6	10.5 3	24	1.66 6	16.2	29.7 6	1.34 4	14.2	27.7 6	1.44						
GFR0-S2	47.7 5	27.1 2	10.5 3	37. 65	1.26 8	16.2	43.3 2	1.1	14.2	41.3 2	1.15						
GFR05-N	21.2 5	---										53.1 3	53.1 3	0.4	51.1 76	51.1 76	0.41 2
GFR05-S1	46.2 5	14.3 6										53.1 3	67.4 9	0.68 5	51.1 76	65.5 36	0.70 5
GFR05-S2	56.2 5	28.7 2										53.1 3	82	0.68 6	51.1 76	79.8 91	0.70 4
GFR1-N	28.7 5	---										67.2	67.2	0.42 7	73.3 66	73.3 66	0.4
GFR1-S1	52.5	15										67.2	82.2	0.63 8	73.3 66	88.3 66	0.6
GFR1-S2	62.5	30.1 2										67.2	97.3 22	0.64 2	73.3 66	103. 5	0.6

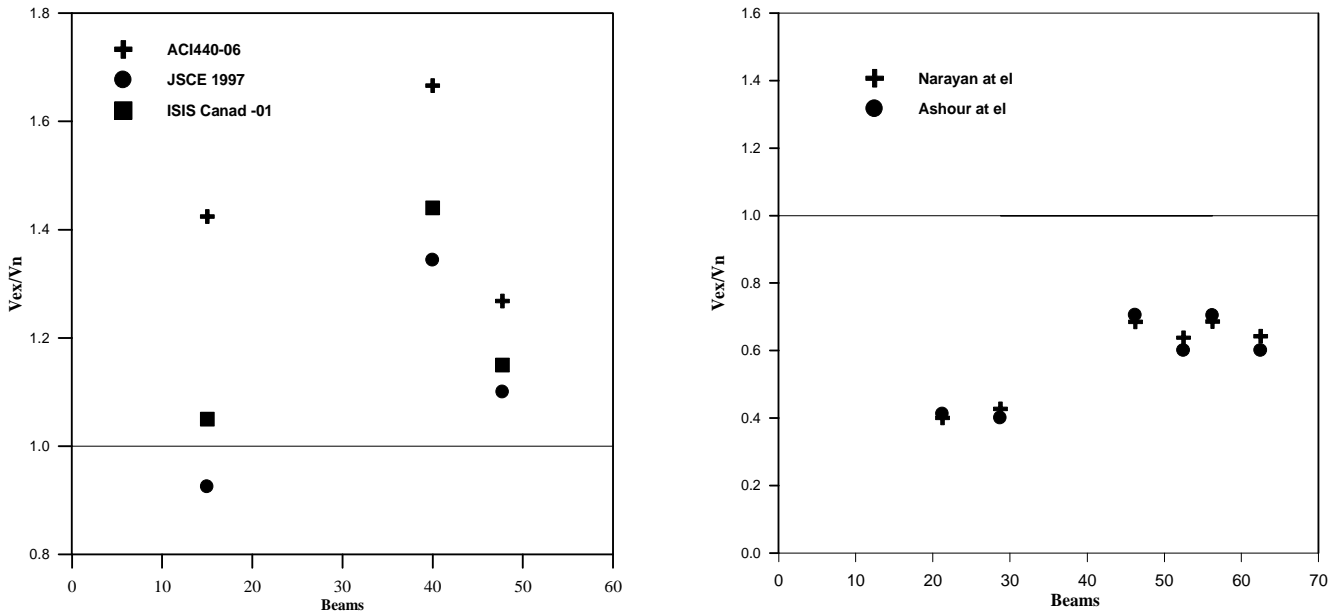

Figure 9 :Experimental to Calculated Shear Strength of FRP-Reinforced Concrete Beams

Based on both the ratio of experimentally measured to analytically calculated shear strength  $V_{ex}/V_n$  and the average absolute error AAE calculate using Eq.(12)

$$AAE = \frac{1}{n} \sum \frac{|V_{ex}-V_n|}{V_{ex}} \dots\dots\dots(12)$$

Table 12 reports the average and standard deviation (SD) for  $V_{ex}/V_n$  ,and the AAE of all shear design equations .It has been that the JSCE-97 has the lowest AAE of 14.305% compared to 30.316% for ACI-06 , 20.022% for ISIS-01 ,81.266% for Narayan and 85.6% for Ashour .

Table (12) :Performance of Shear Equations Considered in this Study

Method	AAE %	$V_{ex}/V_n$ Average	SD
ACI 440-IR-06	30.316	1.452	0.20
JSCE- 1997	14.30	1.123	0.21
ISIS Canada -01	20.02	1.2133	0.202
Narayan at el	81.266	0.580	0.13
Ashour at el	85.60	0.570	0.135

### 5- CONCLUSIONS

The experimental results and analysis on nine steel fiber GFRP beams strengthening in shear with CFRP laminate and one steel RC beam as reference specimen have presented and discussed in this paper .Based on the investigation the following conclusions were made :

- The type of failure depends on percentage of steel fiber and phase of strengthening .
- External bounded reinforcement can be used to enhance the shear capacity of the beams .
- All the beams in group GPR0 failed in diagonal tension and the average ultimate loads were higher than inclined cracking loads about 146.334% .
- All the beams in groups GFR05 and GFR1 failed in shear –compression failure except the beams strengthening with full side bounding by CFRP laminate failed in flexure .The average ultimate loads were higher than inclined cracking loads about 142.2% .
- For the beams strengthening with U-Jacket by CFRP laminate when volume of steel fiber increased 0.5% and 1.0% the increasing in shear strength and the decreasing in mid-span deflection were (15.6 and 31.25)% and (8.43 and 15.42)% respectively .

- For the beams strengthening with full side bounding by CFRP laminate when volume of steel fiber increased 0.5% and 1.0% the increasing in shear strength and the decreasing in mid-span deflection were (17.85 and 30.89)% and (11.81 and 20.3)% respectively .
- Nevertheless ,shear capacity of beams reinforced with GFRP bars and strengthening with CFRP laminate in shear is lower than that beam reinforced with steel bars and steel stirrups .
- Shear design equations of JSCE-97 and ISIS-01 provides better results than of ACI 440-06 for beams without steel fiber .
- The equations suggested to apply for steel fiber concrete GFRP beams shows that there are overestimate the shear capacity .
- The JSCE-97 has the lowest AAE of 14.305% compared to the others shear design equations .

## REFERENCES

- [1] Triantafillou, T.C ., (1997 ), *Shear Strength of Concrete Members Using Composites, Non-Metallic (FRP) Reinforcement for Concrete Structures* Proceeding of the Third Symposium , Vol. 1 , Japan ,Oct. 1997 , pp. 523-530 .
- [2] Jonas Gustafsson and Keivan Noghabai,(1998), *Steel Fibers as Shear reinforcement in High Strength Concrete Beams* [www.kunnskapsdugnad.no/ikbViewer/Content/738968/doc-22-3.pdf](http://www.kunnskapsdugnad.no/ikbViewer/Content/738968/doc-22-3.pdf)
- [3] Chaallal, O. ,Shahawy, M. ,Hassan, M. (2002). *Performance of Reinforced Concrete T-Girder Strengthened in Shear with Carbon Fiber Reinforced Polymer Fabric*, ACI Struct. J.99(3) ,pp. 335-343 .
- [4] P.Alagusundaramoorthy, I.E.Harik and C.C.Choo,(2002), *Shear Strength of R/C Beams Wrapped With CFRP Fabric* ,Research Report,Performing Organization Report , KTC-02-14/SPR 200-99-2F .
- [5] Y.K.Kwak, M.O.Eberhard , W.S.Kim and J.Kim ,(2002), *Shear Strength of Steel Fiber-Reinforced Concrete Beams Without Stirrups* ,ACI Structural Journal ,Vol.99, No.4 , PP. 530-538 .
- [6] Ahmed, O., Hassan, K. (2003), *Repair of RC Cracked Beams Using Externally Bonded CFRP Sheet* Tenth International Colloquium on Structural and Geotechnical Engineering ,April 22-24 ,Ain Shams University ,Cairo ,Egypt, PP.E03 MA 707 (1-11) .
- [7] Boussselham, A. ,and Chaallal, O., (2004). *Shear Strengthening Reinforced Concrete Beams with Fiber-Reinforced Polymer*. Assessment of Influencing Parameters and Required Research , ACI Structural Journal 101(2) , pp. 219-227.
- [8] F.Matta, A.Nanni ,N.Galati , F.Mosele, (2006), *Size Effect Shear Strength of Concrete Beams Reinforced With FRP Bars* , [www.framcos.org/FraMCoS-6/331.pdf](http://www.framcos.org/FraMCoS-6/331.pdf)
- [9] Boussselham, A. ,and Chaallal, O., (2006a) , *Behavior of Reinforced Concrete T-Beams Strengthened in Shear with Carbon Fiber-Reinforced Polymer- An Experimental Study* , ACI Structural Journal 103(3) , PP. 339 , May-June 2006 .
- [10] Boussselham, A. ,and Chaallal, O., (2006b) ,*Effect of Transverse Steel and Shear Span on the Performance of RC Beams Strengthened in Shear With CFRP* ,Composite Engineering Part B, Vol.37 ,No. 1, PP. 37-46 , 2006 .
- [11] Leung , C., Chen, Z. , Lee, S. , Mandy, N., Ming, X. and Tang, J. (2007) ,*Effect of Size on the Failure of Geometrically Similar Concrete Beams Strengthened in Shear with FRP Strips* ,Journal of Composites for Construction, Vol.11 ,No.5 , pp. 487-496 .
- [12] M.H. Jin , H.S. Jang , C.H. Kim and D.I. Baek,(2009), *Concrete Shear Strength of Lightweight Concrete Beam Reinforced With FRP Bar* , Asia Pacific Conference on FRP in Structures ,Seoul, Korea 9-1 ,December 2009, PP. 203-207.
- [13] A. Bukhari, R. L. Vollum, S. Ahmad and J. Sagaseta, (2010), *Shear Strengthening of Reinforced Concrete Beams With CFRP* , Magazine of Concrete Research, 2010, 62, No. 1, January, pp.65-77
- [14] NCHRP Report 678,(2011) ,*Design of FRP Systems for Strengthening Concrete Girder in Shear* , Transportation Research Board ,Business Office,500 Fifth Street,NW, Washington ,D.c., USA..[www.national-academies.org/trb/bookstore](http://www.national-academies.org/trb/bookstore)



- [15] Noor A.A, Rendy T. and Azmi I.,(2013), *Shear Capacity of Non-Metallic (FRP) Reinforced Concrete Beams with Stirrups*, IACSIT International Journal of Engineering and Technology ,Vol.5 . No.5 ,October 2013 .
- [16] Abdeldjelil Belarbi & Bora Acun ,(2013) .*FRP Systems in Shear Strengthening of Reinforced Concrete Structures* , Published by Elsevier Ltd .Available online at [www.sciencedirect](http://www.sciencedirect.com) .com . Procedia Engineering 57 , pp. 2-8 .
- [17] M.B.S Alferjani, A.A. Abdul Samad , Blkasem. S Elrawaff ,N. Mohamad ,(2013), *Use of Carbon Fiber Reinforced Polymer Laminate for strengthening reinforced concrete beams in shear: A review*, International Refereed Journal of Engineering and Science (IRJES), Volume 2, Issue 2(February 2013), PP.45-53.
- [18] Shamsher B Singh,(2013) , *Shear Response and Design of RC beams Strengthened Using CFRP Laminates* ", International Journal of Advanced Structural Engineering , <http://www.advancedstructeng.com/content/5/1/16>
- [19] American Concrete Institute (ACI). (2006), *Guide for The Design and Construction of Concrete Reinforced With FRP Bars* ., Technical Committee Document No. 440.1R-06, 2006. Mich: Farmington Hills .
- [20] Machida, A., ed. (1997). *Recommendation for Design and Construction of Concrete Structures Using Continuous Fibre Reinforcing Materials*, Concrete Engineering Series 23, Japan Society of Civil Engineers, JSCE, Tokyo, Japan, pp. 325 .
- [21] ISIS-M03-01. (2001). *Reinforcing Concrete Structures with Fiber Reinforced Polymers*, The Canadian Network of Centers of Excellence on Intelligent Sensing for Innovative Structures, ISIS Canada, University of Winnipeg, Manitoba, pp.81.
- [22] Narayanan, R.; and Darwish, I.Y.S.,(1987) ,*Use of Fibers as Shear Reinforcement*, ACI Structural Journal, V. 84, No. 3, May - June , pp 216-227.
- [23] Ashour, S.A.; Hasanain, G.S.; and Wafa, F.F.,(1992) , *Shear Behaviour of High Strength Fiber Reinforced Concrete Beams*, ACI Structural Journal, V. 89, No. 2, March-April .
- [24] Khalifa A, Gold W, Nanni A, Abel-Aziz M (1998), *Contribution of externally bonded FRP to the shear capacity of RC flexural members* ,ASCE, J Composites in Construction 2(4): pp.195–203.
- [25] Maeda T, Aano Y, Sato Y, Ueda T, Kakuta Y (1997) , *A study on bond mechanism of carbon fiber sheet* . Proceedings of the Third Symposium on Non-Metallic (FRP) Reinforcement for Concrete Structures, Sapporo, Japan 1: pp.279–286 .
- [26] Replark System ,(2000), *Design Manual. Mitsubishi Chemical Corporation* , Japan. Revision 0.0, March