

# ANTI-CORROSION POTENTIALS OF FRESH EXTRACTS OF OLD *PERSEA AMERICANA* VAR. *AMERICANA* SEED IN 0.5 M H<sub>2</sub>SO<sub>4</sub> ON MILD STEEL

Anthony Chimezie Ehiemere<sup>1</sup>, Rosary Onyekachi Anyanwu<sup>2</sup>, Peace Emele<sup>3</sup>, Uche G. Nwokeke<sup>4</sup>

1. Department of Chemistry, Abia State Polytechnic, Aba, Nigeria
  2. Department of Chemistry, Federal University of Technology, Owerri, Nigeria
  3. Joint Admissions and Matriculation Board, Owerri, Nigeria
  4. Department of Chemistry, Imo State University, Owerri, Nigeria
- EMAIL of the corresponding author: [chimex4tops@yahoo.com](mailto:chimex4tops@yahoo.com)

## ABSTRACT

An experiment to determine effective corrosion inhibition of fresh extracts from matured seed of *Persea Americana* var. *Americana* on mild steel in 0.5 M H<sub>2</sub>SO<sub>4</sub> conditions was carried out using gravimetric and electrochemical methods. The tests were carried out at room temperature for 24 hours, and also for higher temperature from 40°C to 70°C for 3 hours. The results showed that the seed extracts have appreciable corrosion inhibition potentials which decreased with increase in temperature. Inhibition efficiency showed that it increased with increase in inhibitor concentration across the same temperature, and similarly decreased with increase in temperature within the same concentration range. The experimental data fitted in with the Langmuir isotherm which is an indicator that the extract constituents were adsorbed on the steel surface. The Arrhenius equations showed a general increase implying that physisorption rather than chemisorptions is prevalent. The values of the heat of adsorption are all negative for temperatures at 40°C, indicative of the fact that inhibition efficiency decreases with rise in temperature, a proof that the inhibition trend was physisorption. At temperatures of 70°C, the values are mixed, some negative and some positive. This indicates that both physisorption and chemisorptions abound at higher temperatures. The result from potentiodynamic tests shows that reduction in current potential in the presence of the inhibitor at both concentrations implies that it is a mixed inhibitor.

**Keywords:** Corrosion inhibition; Fresh; Higher temperatures; Langmuir isotherm; Matured; *Persea Americana* var. *Americana*.

**DOI:** 10.7176/CMR/13-2-03

**Publication date:** June 30<sup>th</sup> 2021

## 1 INTRODUCTION

### 1.1 Corrosion and Its Effects

Metallic materials are exposed to the atmosphere for different reasons. This leads to corrosion. Corrosion of a metal is said to be due to chemical or electrochemical reactions when it comes in contact with matters present in its environment [1, 2]. Corrosion of engineering structures and components in service has continued to be a huge source of concern to corrosion experts in the academia and industries. This is primarily due to its deleterious effect on material integrity and mechanical properties resulting in failure in severe cases [3].

Corrosion is commonly known to come in various forms. Some of the most common ones include **oxidation, uniform surface corrosion, pitting corrosion, galvanic corrosion, and microbial corrosion.**

To minimize the effect of corrosion, substances called corrosion inhibitors are employed. Corrosion inhibitors are chemical substances which are added in small concentrations to an environment and retard the occurrence of

corrosion reactions [4]. Among the metals that need this protection offered by inhibitors is mild steel. Mild steel has found applications in many industries, but excessive corrosion attack is known to affect this industrial raw material. The corrosion attack can be reduced to a very reasonable state by the use of corrosion inhibitors [5, 6].

Inhibitors currently employed in corrosion works are varied and some have been found to be hazardous to health and the environment at large. Thus efforts are now directed towards formulation of modern environmentally safe inhibitors in which plants extracts have become important because they are eco-friendly; are economically cheap; are readily available; and are renewable sources of effective corrosion inhibitors [1, 7]. Several natural products such as plant extract, amino acids, and biopolymers have been reported to be efficient corrosion inhibitors [18]. Out of these, plant extracts have become important as an environmentally acceptable, readily available and renewable source for wide range of inhibitors. They are the rich sources of ingredients such as fatty acids which have very high inhibition efficiency [16].

Corrosion protection must, as a necessity, always be provided for in metals and alloys in contact with all environments [8].

## 2 EXPERIMENTAL

### 2.1 Preparation of Specimens

The percentage composition of stainless steel used was 0.05%C, 0.60%Mn, 0.36%P, 0.030%S, 18%Cr, 0.75%Si, 8%Ni, 0.10%N, and finally 80%Fe. The steel was cut into various pieces of the same measured dimensions of 1mm x 50mm x 40mm. Holes were drilled in the coupons to enable the insertion of a hanger. The coupons were further wet polished with silicon carbide abrasive paper (from grade 800 – 1600), degreased in absolute ethanol, rinsed in acetone, weighed and stored in moisture-free desiccator prior to corrosion studies.

### 2.2 Method of extraction

Stock solutions of the plants extracts were prepared by reflux boiling of 20 g of the dried, ground, filtered, and weighed sample of *Persea Americana* var. *Americana* for 3 hours in a round-bottomed flask, allowed to cool at room temperature, and filtered using weighed white handkerchief, and stored. From the respective stock solutions, inhibitor test solutions were prepared with concentrations of 100, 500, and 1100 mg L<sup>-1</sup> in the corrodent. The electronic weighing instrument used is OHAUS brand.

### 2.3 Weight Loss Determination

Gravimetric methods were conducted on mild steel coupons of stated dimensions. In the weight loss experiment, four reaction vessels (for each plants specie) labeled BL for blank, and A<sub>1</sub> – A<sub>3</sub> for samples containing various masses of the inhibitor in 0.5 M of the corrodent. The mild steel coupons were carefully weighed and properly tagged to avoid mix up. These coupons were suspended (under total immersion conditions) in the reaction vessels containing 200 ml of the test solutions with the aid of twine and broom sticks. All tests were made in aerated solutions. In the first experiments for each corrodent, the coupons were retrieved after 24 hours.

The other experiments were for the effects of temperature in which the enabling ranges were for 40, and 70 °C, respectively, for 1 hour.

In each case, the retrieved coupons were scrubbed with bristle (smokers) brush under water, dipped in absolute ethanol, rinsed with water, dried in acetone, and reweighed.

The weight loss was a simple difference between the initial mass and the final mass retrieved from the corrodent solutions.

The evaluated results were for (i) Inhibition efficiency,  $\eta$  (I.E.) in percentage, given by

$$\eta\% = \left(1 - \frac{\Delta M_{SP}}{\Delta M_{IN}}\right) \times 100 \quad (1)$$

where  $\Delta M$  = mass loss; SP = sample; IN = inhibitor; and (ii) Corrosion rate,  $\rho$ , given by

$$\rho = \frac{KW}{DA T} \quad (2)$$

where  $K$  = rate constant (534 mpy; mils per year, 1 mil =  $10^{-3}$  in);  $W$  = mass loss in mg;  $D$  = density of the mild steel coupon ( $7.85 \text{ g cm}^{-3}$ );  $T$  = immersion time(h);  $A$  = exposed area of the coupon ( $0.1911 \text{ cm}^2$ ).

#### 2.4 Electrochemical measurements

Electrochemical tests were conducted in a conventional three-electrode corrosion cell, using a V3 Potentiostat/Galvanostat, coupled to a PC, running on the Powersuite and Powersine software. A graphite rod and saturated calomel electrode (SCE) served as counter and reference electrodes respectively. Test metal specimens were fixed in epoxy resin with a surface area of  $1 \text{ cm}^2$  exposed to the test solution. Measurements were in aerated and unstirred solutions at the end of 1800s of immersion at  $30 \pm 1 \text{ }^\circ\text{C}$ . Each test was run in triplicate and the mean values of the measured parameters presented.

Impedance measurements were carried out using signal amplitude perturbation of 5 mV at the corrosion potentials ( $E_{\text{corr}}$ ) and frequency range 100 kHz - 0.1 Hz. The resulting impedance data were analyzed using Zsimpwin 3.0 software. Potentiodynamic polarization measurements were performed at a scan rate of 0.333 mV/s and potential range  $\pm 250 \text{ mV}$  versus corrosion potential.

### 3 RESULTS AND DISCUSSION

#### 3.1 Results

Figures 1 and 2 below are showing the results gotten when corrosion rate and inhibition efficiency are each plotted against concentration values of 100, 500, and 1100  $\text{mg L}^{-1}$ . The results show that **fresh extracts of matured *Persea Americana* seed** effectively inhibit corrosion on mild steel coupon in 0.5 M  $\text{H}_2\text{SO}_4$  solution as corrodent, and that there is a marked difference between the solutions without the inhibitor from those with inhibitor. Inhibition efficiency increases with increase in inhibitor concentration generally.

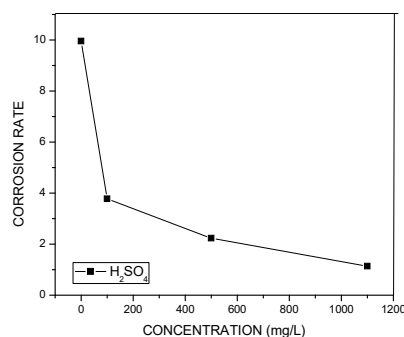

**Figure 1: Corrosion rate v Concentration for coupons at room temperatures for 24 h**

Here, there is a sharp drop in the first part of the curve which indicates that without inhibition, corrosion is in a free flow. However, introduction of the inhibitor slows the corrosion process considerably resulting in the curve observed. This trend is observed for all plots obtained for varying reactions throughout this experiment.

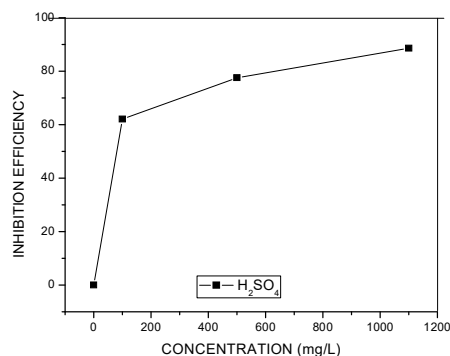

**Figure 2: Inhibition efficiency v concentration for coupons at room temperature for 24 h**

Figures 3 to 6 are showing the plots of corrosion rate and inhibition efficiency respectively against concentration at temperatures above normal room temperature. In Figure 3, corrosion rate is plotted against concentration at 313 K, and the result is that for the solution without inhibitor, the rate of corrosion is fastest. For the other specimens however, there was improved corrosion rate inhibition which varied as a function of temperature. Thus, increase in temperature has a corresponding increase in corrosion rate as increase in temperature increases the rate of a chemical reaction. The same observation is made in the experiment at 343 K (Fig. 5).

The values for inhibition efficiency follow a corresponding trend. Increase in inhibitor concentration leads to a corresponding increase in inhibition efficiency, though the values are less than the case of the experiment at room temperature (Fig. 2). The same is observed for Figure 6.

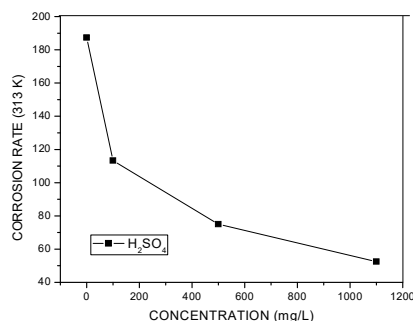

**Figure 3: Corrosion rate v concentration for coupons at 313 K for 1 h**

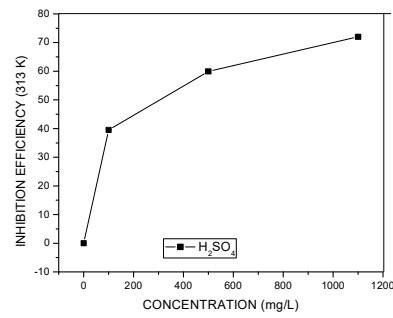

**Figure 4: Inhibition efficiency v concentration for coupons at 313 K for 1 h**

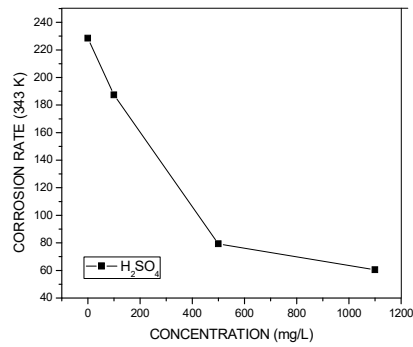

**Figure 5: Corrosion rate v concentration for coupons at 343 K for 1 h**

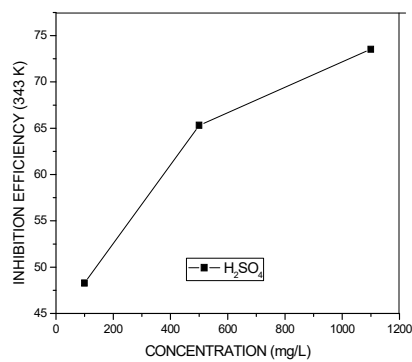

**Figure 6: Inhibition efficiency v concentration for coupons at 343 K for 1 h**

### 3.2 Temperature Considerations

We can deduce from the plots (Figures 7& 8) that corrosion inhibition of matured *Persea Americana* seed extracts in the presence of 0.5 M H<sub>2</sub>SO<sub>4</sub> is efficient. This is indicated by the plots gotten in which there is little or no overlapping of the results when the corrosion rates are considered in the presence and absence of the inhibitor. However, there is increase in corrosion rate when rate is considered at same concentration but with reaction temperatures elevated. From these results, we can deduce that the corrosion rate increases in the blank solution with rise of temperature [9], but in the presence of the inhibitors, the dissolution of mild steel is widely retarded.

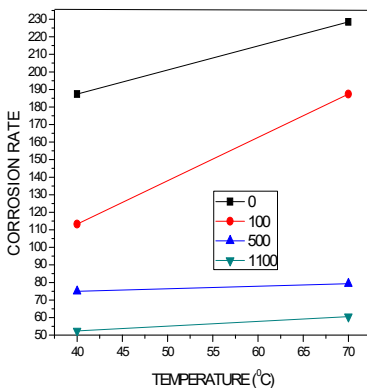

Figure 7: Variation of corrosion rate with temperature at different concentrations

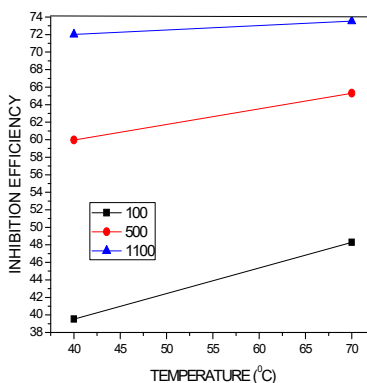

Figure 8: Variation of inhibition efficiency with temperature at different concentrations

In all cases, increase in corrosion rates accompany temperature increase which is a phenomenon observed for media where hydrogen gas evolution accompanies corrosion resulting in higher dissolution rates. Similarly, a decrease in corrosion rates is observed as the concentration of the inhibitor is increased and tends to resist the effect of temperature elevation. For most organic corrosion inhibitors wherein the trend is attributed to physisorption rather than chemisorption of the inhibitor on the corroding metal surface, higher rates of hydrogen gas generation increasingly agitate the metal/corrodent interface and could hinder inhibitor adsorption or perturb already adsorbed inhibitor, especially when the interaction between the metal and the inhibitor is relatively weak [10].

### 3.2.1 The Langmuir Isotherm and Arrhenius equation

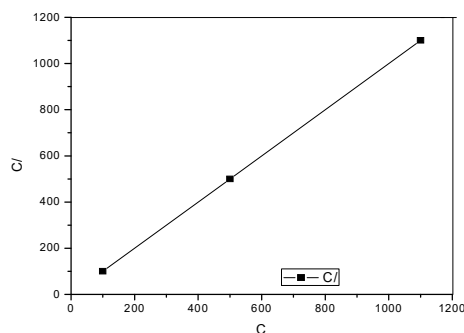

FIGURE 9: Plot of Langmuir isotherm

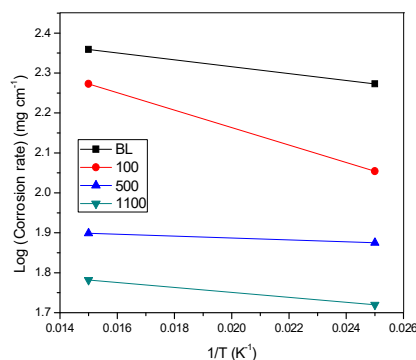

Figure 10: Arrhenius plot for mild steel in 0.5 M H<sub>2</sub>SO<sub>4</sub> environment and at different temperatures

The adsorption isotherm fits perfectly into the Langmuir isotherm descriptions more than any other isotherm and many were considered. The molecule responsible for this isotherm was not determined. So,  $\Delta G_{ads}$  was not considered. The data fits into a straight line and the slope is nearly one (1). This means that this compound adsorbs according to the Langmuir isotherm. In such case, the inhibition is explained as a synergistic intermolecular effect of the various components of the natural substances present [11].

The Arrhenius equation ( $k = A \exp(-E_a/RT)$ ) can be related to corrosion rate ( $\rho$ ) and temperature ( $T$ ), where  $E_a$  is the activation energy,  $A$  the Arrhenius pre-exponential factor, and  $R$  the universal gas constant.

$$E_a = (ln A - ln k) RT \quad (3)$$

The apparent activation energies for mild steel corrosion from Arrhenius equation is given in Table 1 below.

### 3.2.2 Further Calculations

**1. Apparent Activation Energies ( $E_a$ ):** Activation energy may be defined as the minimum energy needed to start a “chemical reaction”. It can also be described as the minimum energy which must be available for a chemical system with potential reactants to result in a “chemical reaction”. Thus the calculation of apparent activation energies for mild steel corrosion was deduced from Arrhenius equation:

$$\log \frac{p_2}{p_1} = \frac{E_a}{2.303RT} \left( \frac{1}{T_1} - \frac{1}{T_2} \right) \quad (4)$$

Where;  $p$  = Corrosion rate;  $T$  = Temperature

In the Table 1 below, we can see that the activation energy increases for all temperatures considered proving clearly that physical adsorption rather than chemical adsorption is active in this inhibitor specie [12]. This is also shown by the increase in activation energy from the blank reaction to the inhibited reaction.

**2. Heat of Adsorption ( $Q_{ads}$ ):** The heat of adsorption,  $Q_{ads}$ , is the heat evolved when a given amount of a substance is adsorbed. It is another thermodynamic parameter which describes the adsorption mechanism and is connected to the degree of surface coverage,  $\theta$ , ( $\eta\% = \theta$ ), through this relation:

$$Q_{ads} = 2.303R \left\{ \log \left[ \frac{\theta_2}{1-\theta_2} \right] - \log \left[ \frac{\theta_1}{1-\theta_1} \right] \right\} \times \left( \frac{1}{T_1} - \frac{1}{T_2} \right) \quad (5)$$

Where  $\theta_1$  and  $\theta_2$  are the values of the degree of surface coverage of temperature  $T_1$  and  $T_2$ , respectively

**TABLE 1: Table of values showing the results of heat of adsorption ( $Q_{ads}$ ) and activation energy ( $E_a$ ) for mild steel carrion at temperatures of 40°C and 70°C respectively**

C <sub>1</sub> (mg/L)	40°C		70°C	
	Activation Energy (kJ/mol)	Heat of Adsorption (kJ/mol)	Activation Energy (kJ/mol)	Heat of Adsorption (kJ/mol)
Blank	444.212	-	42.1271	-
100	514.7691	- 0.1144	8.9407	0.0317
500	531.8966	- 0.1044	11.7043	0.0203
1100	579.9361	- 0.1377	30.2834	0.0068

From the table above, the values of activation energy ( $E_a$ ) and heat of adsorption ( $Q_{ads}$ ) at temperature 40°C were higher than the values of activation energy at temperature of 70°C. The heats of adsorption ( $Q_{ads}$ ) at temperature of 40°C were physisorption values while that of 70°C were chemisorption.

### 3.3 Potentiodynamic Polarization Measurement (PDP)

The criteria to classify inhibitors as cathodic, anodic, or mixed-type inhibitor is a function of the changes observed in polarization curves after addition of the inhibitor. Thus, the Potentiodynamic polarization experiment was undertaken to distinguish the effect of **fresh** extracts of matured *Persea Americana* seed extract on the anodic and cathodic corrosion reactions.

The values of the corrosion current density in the absence ( $i_{corr, bi}$ ) and presence of inhibitor ( $i_{corr, inh}$ ) were used to estimate the inhibition efficiency from polarization data (IE%) as follows:

$$IE\% = \left( \frac{i_{corr(bi)} - i_{corr(inh)}}{i_{corr(bi)}} \right) \times 100 \quad (6)$$

Where  $I_{corr(bi)}$  and  $I_{corr(inh)}$  represents the corrosion current density in the absence and presence of the inhibitor, respectively.

Potentiodynamic polarization curves for mild steel in 0.5 M  $H_2SO_4$  containing different 100 and 1000 mg/L of PA at 30 °C are represented in Figure 11 below. The metal coupon is seen to dissolve fast without any form of resort to retardation within the studied potential range. The behavior of the polarization curves in 0.5 M  $H_2SO_4$  environment (Figure 11) shows that the presence of PA inhibitor shifts the cathodic and anodic curves towards the area of lower current densities, just as the addition of PA into the acidic solution has no noticeable effect on the corrosion potential ( $E_{corr}$ ) in each case. Results as shown in Table 2 reveal that the highest displacement in  $E_{corr}$  value in the studied acidic solutions was less than 85 mV, an indicator that PA can be regarded as a mixed-type inhibitor.



All the corresponding electrochemical parameters like the corrosion current densities ( $I_{corr}$ ), corrosion potential ( $E_{corr}$ ), cathodic Tafel slopes ( $b_c$ ) and anodic Tafel slopes ( $b_a$ ) obtained from polarization curves are shown in Table 2, which also show that the corrosion current density decreased significantly in the presence of PA inhibitor compared to the uninhibited solution and also decreased with an increase in the concentration of the extract. The inhibition efficiency was calculated using the equation:

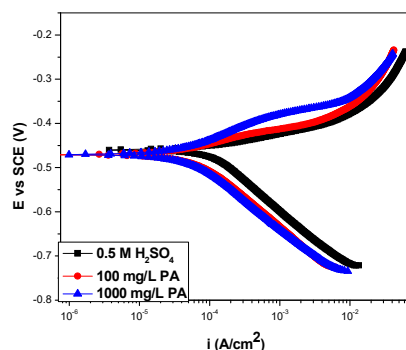

**FIGURE 11: Potentiodynamic polarization curves of mild steel in 0.5 M H<sub>2</sub>SO<sub>4</sub> in the absence and presence of matured *Persea Americana* seed extract**

**TABLE 2: Table showing the result of polarization parameters for corrosion of mild steel in 0.5 M H<sub>2</sub>SO<sub>4</sub> in the absence and presence of matured *Persea Americana* seed (PA) extracts**

SYSTEM	$E_{corr}$	$I_{corr}$	$\theta$	IE (%)	
BLANK	-	496.7	1340		
100 mg L <sup>-1</sup>	-	491.3	758.2	0.434	43.4
1000 mg L <sup>-1</sup>	-	456.4	120.7	0.909	90.9

The values of double-layer capacitance ( $C_{dl}$ ) were determined at the frequency at which imaginary component of the impedance is a maximum ( $Z_{im(max)}$ ) using the equation:

$$f(Z_{im(max)}) = \frac{1}{2\pi C_{dl} R_{ct}} \quad (7)$$

$$IE\% = \left( \frac{R_{ct(inh)} - R_{ct}}{R_{ct(inh)}} \right) \times 100 \quad (8)$$

### 3.4 Electrochemical Impedance Spectroscopy (Eis) Measurements

**Table 3: Electrochemical Impedance Parameters of Mild Steel in 0.5 M H<sub>2</sub>SO<sub>4</sub> in the Absence and Presence of matured *Persea Americana* (PA) seed extracts.**

SYSTEM	$R_s(\Omega \text{ cm}^2)$	$R_{ct}(\Omega \text{ cm}^2)$	N	$C_{dl}(\text{F cm}^{-2})$	IE
BLANK	2.061	28.02	0.89	<b>1.131E-4</b>	
100 mg L <sup>-1</sup>	2.89	47.1	0.88	5.144E-5	40.2
1000 mg L <sup>-1</sup>	3.25	265	0.89	4.371E-5	89.4

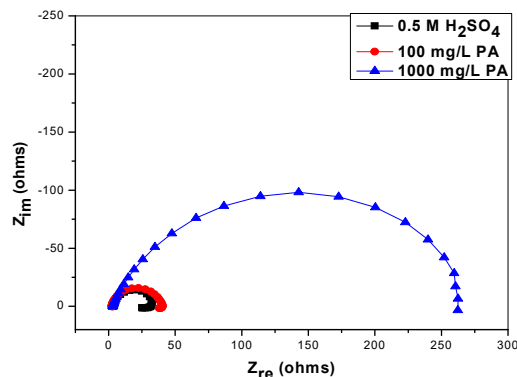

**FIGURE 12: Impedance spectra of mild steel in 0.5 M H<sub>2</sub>SO<sub>4</sub> in the absence and presence of young PA leave extracts.**

The corrosion response of MS in 0.5 M H<sub>2</sub>SO<sub>4</sub> in the presence and absence of inhibitor has been investigated using Electrochemical Impedance Spectroscopy. Fig. 12 represents the Nyquist plots of MS specimens in 0.5 M H<sub>2</sub>SO<sub>4</sub>. It is evident from the plots that the impedance response of metal specimens showed a marked difference in the presence and absence of the inhibitor. The semicircles showed slight irregularity which may be attributed to the roughness or non homogeneous nature of the metal surface [13]. The capacitance loop intersects the real axis at higher and lower frequencies. At high frequency end the intercept corresponds to the solution resistance (R<sub>s</sub>) and at lower frequency end corresponds to the sum of R<sub>s</sub> and charge transfer resistance (R<sub>ct</sub>). The difference between the two values gives R<sub>ct</sub>. The value of R<sub>ct</sub> is a measure of electron transfer across the exposed area of the metal surface and it is inversely proportional to rate of corrosion [14].

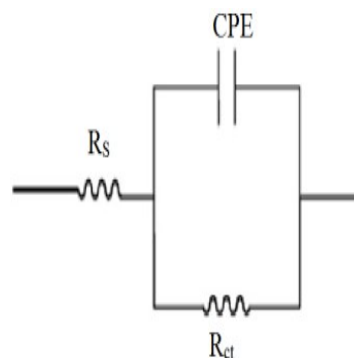
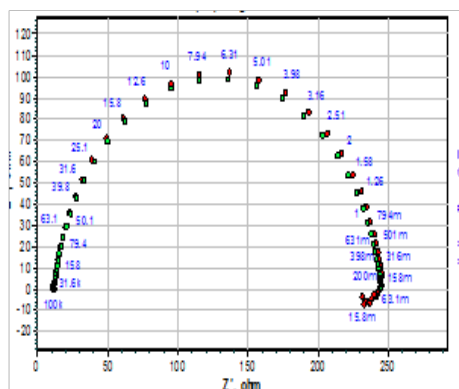

## CONCLUSIONS

Avocado pear seed is a biomass which is very commonly available, as has been noted elsewhere in this work. Several reports demonstrated that the sustainable use of bio products is good alternative to the synthesis of environmentally friendly inhibitors with high corrosion inhibition efficiencies (Swathi *et al.*, 2017).

The ability of matured *Persea Americana* seed extracts to inhibit corrosion in the presence of 0.5 M H<sub>2</sub>SO<sub>4</sub> is clearly shown to be a successful experiment. The inhibition efficiency increases with increase in concentration of the extract, but decreases noticeably as temperature increases up to a higher concentration of 1100mg/l of the inhibitor. The heat of adsorption (Q<sub>ads</sub>) at of temperature of 40°C were physisorption values while that of 70°C were chemisorption as was observed from the values of Q<sub>ads</sub>. The potentiodynamic polarization (PDP) results revealed that matured *Persea Americana* seed extract is a mixed inhibitor under the prevailing condition of 0.5 M H<sub>2</sub>SO<sub>4</sub>.

The fruits of *Persea Americana* of all variants are known to be oily. Food scientists are known to be able to transform the ripe fruits to a form of butter by ordinary kitchen processes. This means that it has a form of natural ability to retard corrosion. It is therefore no surprise that the seed can also possess corrosion inhibition potentials. Previous phytochemical studies of avocado seeds identified various classes of natural products, such as phytosterols, triterpenes (Werman et al., 1990), fatty acids with olefinic, and acetylenic bonds (Kashman et al., 1969). Swathi *et al.*, (2017) noted that several fatty acids and their derivatives have been preferably studied for the corrosion inhibition of mild steel samples as they are more environmentally benign, less toxic and more cost effective. Structural modification of many fatty acids resulted in various heterocyclic derivatives, hence provided more active centers in their structures; which enabled easy adsorption on metal surface [19, 20].

### Saturated Fatty Acid

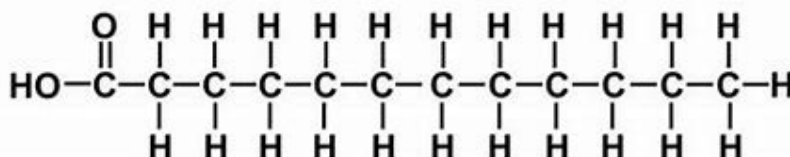

### Unsaturated Fatty Acid

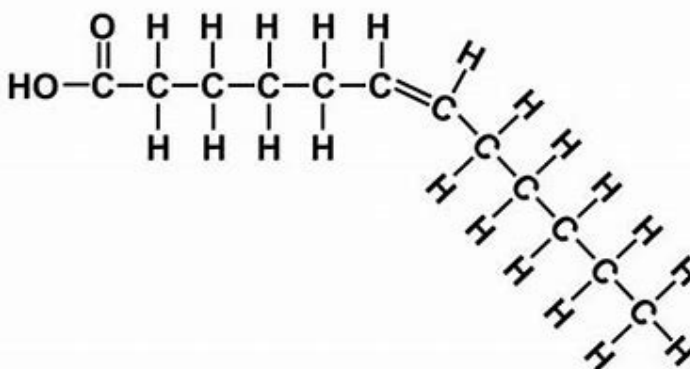

These ideas all the more explain the ability of *Persea Americana* seed as a successful corrosion inhibitor. Its potentials as a corrosion inhibitor was found perfect as a mixed indicator which means that it can act as a physical or chemical adsorption inhibitor depending on the temperature range being addressed.

**Funding:** This study received no specific financial support.

**Competing Interests:** The authors declare that they have no competing interests.

**Contributors/Acknowledgement:** All authors contributed equally to the conception and design of the study.

### REFERENCES

1. Nwankwo, M. O., Offor, P.O., Neife, S. I., Lucky C. Oshionwu, L. C., Idenyi, N. E. (2013). *Amarantus cordatus* as a Green Corrosion Inhibitor for Mild Steel in H<sub>2</sub>SO<sub>4</sub> and NaCl, *Journal of Minerals and Materials Characterization and Engineering*, Vol.2 No.3, Article ID:45857,6 pages  
DOI:10.4236/jmmce.2014.23024
2. Sanyal, B. (1981) Progress in Organic Coatings. *Journal of Chemica Acta*, 9, 165-236.

3. Ahmad, Z. (2006). *Principles of Corrosion Engineering and Corrosion Control*, Butterworth-Heinemann, Oxford.
4. Fernando, B. M., Thais, M. B., Utsch, M., Antonio, C. M. R. (2014). Performance of corrosion inhibitors based on n-butylamine in protection of carbon steel in hydrochloric acid solution, *International Refereed Journal of Engineering and Science*, 3, p. 38-42.
5. Benali, O., Benmehdi, H., Hasnaoui, O., Selles C., and Salghi, R. (2013). Green corrosion inhibitor: inhibitive action of tannin extract of *Chamaerops Humilis* plant for the corrosion of mild steel in 0.5 M H<sub>2</sub>SO<sub>4</sub>, *J. Mater. Environ. Sci.* 4, 127-138.
6. Adindu, C. B., Oguzie E. E., Chidiebere, M. A. (2016). Corrosion Inhibition and Adsorption Behavior of Extract of *Funtumia elastica* on Mild Steel in Acidic Solution, *International Letters of Chemistry, Physics and Astronomy* ISSN: 2299-3843, Vol. 66, pp 119-132, doi:10.18052/www.scipress.com/ILCPA.66.119
7. Raja, B. and Sethuraman, M.G. (2008) Inhibitive Effect of Black Pepper Extract on the Sulphuric Acid Corrosion of Mild Steel. *Materials Letter*, 62, 113-116. <http://dx.doi.org/10.1016/j.matlet.2007.04.079>
8. Nuhu, A. A. (2002). Inhibition Characteristics of Watermelon Oil on Aluminium in Acids and Saline Water, *AU J.T.* 15(4): 265-272
9. Hmamou, J., Rochdi, A., Touri, R., EbnTouhami, M., Rifi, E. H., El Hallaoui, A., Anouar, A., Chebab, D., (2012); "Study of corrosion inhibition of mild steel in acidic medium by 2-propargyl-5-p-chlorophenyltetrazole : Part I." *J. Mater. Environ. Sci.* 3 (3) 543-550
10. Ihebrodike M. M., Michael C. N., Kelechukwu B. O., Lebe A. N., Maduabuchi A. C., Francis, C. E., Oguzie, E. E., (2012). "Experimental and theoretical assessment of the inhibiting action of *Aspilia africana* extract on corrosion of aluminum alloy AA3003 in hydrochloric acid," *J Mater Sci.*,47(6):2559-2572
11. Dahmani, H. M., Et-Touhami, A., Al-Deyab, S. S., Hammouti, B., Bouyanzer, A., (2010). "Corrosion Inhibition of C38 Steel in 1 M HCl: A Comparative Study of Black Pepper Extract and Its Isolated Piperine," *Int. J. Electrochem. Sci.*, 5(2010):1060-1069 (PDF 138 K)
12. Ekanem, U. F., Umorem, S. A., Udousoro, I. I., Udoh, A. P., (2010). Inhibition of mild steel corrosion in HCl using pineapple leaves (*Ananascomosus L.*) extract," *J Mater Sci*, 45(20):5558 – 5566
13. Hassan, H. H., Abdelghani E., Amin, M. A. (2007). Inhibition of mild steel corrosion in hydrochloric acid solution by triazole derivatives: Part I. Polarization and EIS studies, *Electrochimica Acta*, 52(22), 6359-6366.
14. Kashman, Y., Néeman, I., Lifshitz, A. (1969). New compounds from avocado pear, *Tetrahedron, Volume 25, Issue 18, 1969, Pages 4617-4631*, [https://doi.org/10.1016/S0040-4020\(01\)83005-2](https://doi.org/10.1016/S0040-4020(01)83005-2)
15. Rosenfield, I.L. (1981). *Corrosion Inhibitors* (McGraw-Hill, New York, p.66).
16. Swathi, P. N., Rasheeda, K., Samshuddin, S., Alva, V. D. P. (2017). Fatty Acids and Its Derivatives as Corrosion Inhibitors for Mild Steel – An Overview. *Journal of Asian Scientific Research* ISSN(e): 2223-1331 ISSN(p): 2226-5724 DOI: 10.18488/journal.2.2017.78.301.308 Vol. 7, No. 8, 301-308, URL: [www.aessweb.com](http://www.aessweb.com)
17. Werman, M. J., Mokady, S., Neem, I. (1990). Partial isolation and characterization of a new natural inhibitor of lysyl oxidase from avocado seed oil, *J. Agric. Food Chem.* 38, 12, 2164–2168 <https://doi.org/10.1021/jf00102a013>
18. Raja, P. B. and Sethuraman, M. G. (2008). "Natural products as corrosion inhibitor for metals in corrosive media — A review," *Materials Letters*, vol. 62, pp. 113-116. *View at Google Scholar | View at Publisher*
19. Osman, M. M. and Shalaby, M. N. (2003) "Some ethoxylated fatty acids as corrosion inhibitors for low carbon steel in formation water," *Materials Chemistry and Physics*, vol. 77, pp. 261-269. *View at Google Scholar | View at Publisher*
20. Szauer, T. and Brandt, A. (1981). "On the role of fatty acid in adsorption and corrosion inhibition of iron by amine - Fatty acid salts in acidic solution," *Electrochimica Acta*, vol. 26, pp. 1257-1260. *View at Google Scholar | View at Publisher*