

Design of an Intelligent Poultry Feed and Water Dispensing System Using Fuzzy Logic Control Technique

O M Olaniyi*, A. F. Salami*, O. O. Adewumi, O. S. Ajibola

Department of Computer Engineering , School of Information and Communication Technology

Federal University of Technology, P. M. B. 65, Minna, Niger State, Nigeria

*Emails of the Corresponding author: mikail.olaniyi@futminna.edu.ng, abdul.salami@futminna.edu.ng

Abstract

Prohibitive cost of production and laborious human involvement in poultry farms in the tropics could lead to low profit yield and low return on investment. Unfortunately, over-involvement of humans in the feeding system of poultry could lead to disease outbreak, undue fatigue and malnutrition of birds. These flaws in the poor feeding system of birds prompted this research work by developing an intelligent fuzzy logic based system that could mimic the roles of the poultry attendants in delivering water and feed dispensing for birds at specified time intervals. Water and feed level in the trough would be sensed by the designed system and dispense intelligently with respect to the variations in water and feed level as birds consume the feed and water. This system reduces workload of the poultry attendants, increases cost benefits and generates better return on investment in a deep litter poultry farming system

Keywords: Microcontroller, Fuzzy Logic, Artificial Intelligence, Poultry Control System, Intelligent Water Dispensing, Deep Litter System

1. Introduction

Rearing of a collective group of birds such as turkeys, guinea fowls, quails, ostriches, geese and domestic chickens is referred to as poultry. Egg and meat production are the primary purpose of keeping these birds. Other purpose includes pillow production through the industrial processing of the birds' feather and production of confectioneries [1, 2, 9]. The primary production of meat and egg in poultry management is indispensable which makes poultry industry one of the main sources of protein for human consumption. Effective management of poultry nutrition would definitely result to a tremendous production. Whereas, feeding of birds is driven manually in the tropics [2].

The cost of production in poultry farming is aggravated due to the challenge of manual pattern of feeding. Seventy five percent of the cost of production in poultry management could be traced to the expenses on feeding [8]. Wastage of feed, improper administration of feed, unfavorable weather in the poultry, stressful manual labour, disease outbreak, fatigue are all effects of the manual system of feeding. These factors make the cost of production in poultry to be highly capital intensive and unfortunately, people are discouraged from venturing into poultry business due to these factors. Moreover, job such as picking of eggs lay by matured layers, medication of sick birds and overhauling of the litter material interferes with feeding. Thereby, making the pressure that the farmers experiences to increase as the number of birds increases [11].

The flaws mentioned above prompted the development of technologies that could tackle and solve some of the flaws in the most current system of feeding poultry in the tropics; intervention of the development of feed dispensing system that could supply water to birds at appropriate time intervals. In [1], the researchers developed a system of this nature. The operation of this proposed system was contingent of computer system to function. In addition, the system could not sense obstruction while operating. Also in the year 2006, a similar system was proposed by [10]. The operation of this system depends on its position (could only move in horizontal and vertical direction axis). Limitation of dependence on the control program written on computer systems was associated with the proposed system in [1, 10]. Whereby, parallel port is the medium through which control program delivers operation to the system. Unfortunately, cross talk, high initial cost of the computer process control, high maintenance and declination in the level of performance in long distance parallel transmission are problems that could be attributed to the computer parallel port [3].

Solution to some of the limitations in the existing literatures led to the development of a mobile intelligent poultry feed dispensing system in [3]. The principle of implementing a microcontroller as the process controller instead of the program written on the computer system was adopted in this system. The system proposed in [3], dispenses feed on the pen' floor as it operate. Therefore, unhygienic method of feed dispensing and wastage of feed is associated with the model. Besides, large number of birds could not be fed uniformly with this model.

Nevertheless, only feed is catered for in this model. Water is still expected to be manually dispensed for the birds, which could still be attributed to over human involvement in the feeding system of birds.

These limitations highlighted above necessitate for the emergence of a system that would be capable of dispensing both the liquid feed (water) and solid feed (grains) simultaneously into the respective feeding trough in a hygienic manner. The design of a system of this nature is proposed in this research paper. Fuzzy logic is the control methodology adopted in achieving such system design. Fuzzy logic has the ability of imitating the human ability of making decision and taking action in uncertainty scenarios. Fuzzy logic also possesses the human quality of adapting to changes in the environment where they exist. This research work therefore, present an intelligent poultry feed and water dispensing system capable of sensing the feed and water level state in the trough and intelligently dispense more feed and water as the water and feed level drops as birds consumes from it (ensuring that there is never feed and water shortage). This proposed design would ensure constant supply of fresh water and recommended amount of feed to the respective birds' feeding trough. The system is stationary as it dispenses water and feed into the appropriate trough. It would be effective in a deep litter poultry farming system.

2. Fuzzy Logic

Fuzzy logic refers to a control methodology that is capable of suggesting inaccuracy and imprecision. The way human brain think and solve problems can be mimicked by fuzzy logic. The objective of fuzzy logic is to estimate human evaluation making in vague scenarios using conventional statements instead of quantitative terms. The relationship between the input and the output of real life systems can be monitored by fuzzy logic [7]. Fuzzy logic is applied in this research work due to its inherently robust characteristic as it makes the system to make right decision in an imprecise situation and adapt to changes in its environment. Also, it can be adjusted and tweaked easily to improve or drastically alter system performance. Smooth control function is obtained as the output despite a wide range of input variations [12].

2.1 Fuzzy Logic Controller

The operation of real life systems is controlled by Fuzzy Logic Controller (FLC) with the aid of simple rule-based IF X AND Y THEN Z statement. FLC is used in solving control problems rather than rather than mathematical problem solving approaches [5].

The FLC model is based on a verifiable observation instead of computer logic and theory. It operations depends on the operator's understanding of the system rather than their technical understanding of the system. For example, rather than dealing with temperature control in terms such as "SP =500F", "T <1000F", or "210C <TEMP <220C", terms like "IF (process is too cool) AND (process is getting colder) THEN (add heat to the process)" or "IF (process is too hot) AND (process is heating rapidly) THEN (cool the process quickly)" are used. Despite the impressiveness of these statements, yet they are very descriptive of the instruction to be executed. FLC is capable of imitating this type of behaviour at a very high rate. The block diagram depicted in figure 1 shows step by step involve in designing FLC [4].

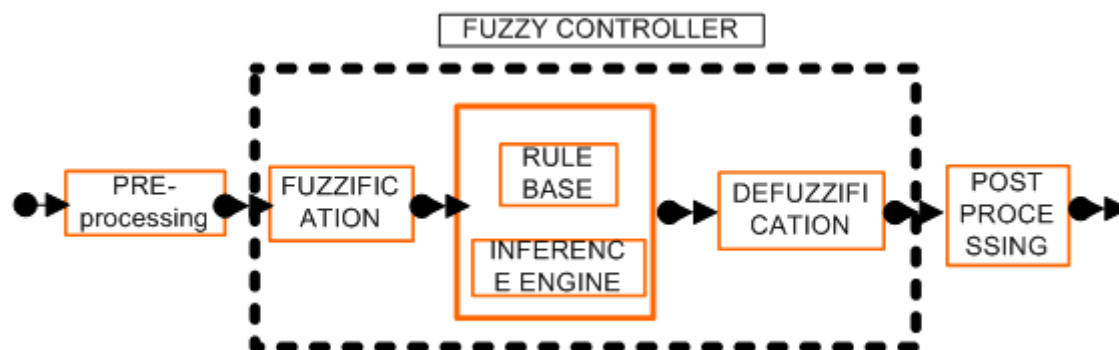

Figure 1. Fuzzy Logic Controller Block Diagram

Preprocessing: It is the first step involved in the design of a fuzzy logic controller. Preprocessing is the process by which the input variables to be measured are been conditioned before they enter the fuzzy logic controller [6].

Fuzzification: This is the first block present in the fuzzy logic controller. It makes the input data to correspond with the rule base conditions. Fuzzification converts each input of data piece to degree of membership by searching in several membership functions [6].

Rule Base: This is used to describe fuzzy set and fuzzy operators as fuzzy logic subjects and verbs in form of conditional statement. This conditional statement is based on an IF –THEN statement which makes fuzzy to be useful for example: If j is P then k is Q where P is a set of conditions that have to be satisfied and Q is a set of consequences that can be inferred. For example: Example: If rain fall Then grass is wet. One of the rule formats of a fuzzy set is shown in figure 2 below:

Error	Change in Error	Output
Negative	Positive	Zero
Negative	Zero	NM
Negative	Negative	NB
Zero	Positive	PM
Zero	Zero	Zero
Zero	Negative	NM
Positive	Positive	PB
Positive	Zero	PM
Positive	Negative	Zero

Figure 2: Tabularized Fuzzy Logic Rules

The two left columns represent all the input variables, while the right most represents the output.

A membership function: is the graphical representation of the magnitude of participation of each input; it also maps the fuzzy set input vales to the appropriate membership value. The main condition a membership function must satisfy is that it must vary between zero and one (0 & 1), the types of membership functions available are, triangular, trapezoidal, Gaussian distribution curve and signmoidal, e.t.c.

Logical Operation describes the truth of any statement with respect to degree. The input values can be real numbers between 0 and 1. For example:

A	B	A and B	A	B	A or B	A not A
0	0	0	0	0	0	0 1
0	1	1	0	1	1	1 0
1	0	1	1	0	1	
1	1	1	1	1	1	
		AND			OR	NOT

Figure 3. Logical Operations in Fuzzy Logic

And specify the minimum operator of A &B, OR specify the Maximum Operator of A & B while NOT signifies $1 - A$.

Inference Engine This allows the mapping of the input data to the output with the use of fuzzy logic controller. Inference engine involves determining the firing strength of each rule of the system

Defuzzification Is the process of moving from a fuzzy set to a point where a control decision can be made. Defuzzification process depends on the type of fuzzy data that is been processed which can involve approximation of linguistic variable or an arithmetic method. Defuzzification process involves the task to find one single crisp value that summaries the fuzzy set. Some of the methods are, centroid, bisection, largest of maximum, smallest of maximum, middle of maximum and weight average.

Post-processing This involves the output scaling of the fuzzy logic control. It involves the tuning of the output gain to an engineering scaled unit such as kilogram, volts, e.t.c.

3. System Design Considerations

The intelligent feed dispensing system was designed through considerations from hardware and software point of views/units. These units are further divided into sub- units that are co-dependent on each other. These unit comprise of the Hardware Unit (Microcontroller, the fuzzy logic engine; the motor, DC water pump, Drinking trough, Feeding trough, sensors and sensor interface circuits, the power supply unit, the sensing unit, buzzer, display unit) and the software unit (design of Fuzzy Logic Engine and development equivalent C language).The overall block diagram of the system is shown in figure 4.

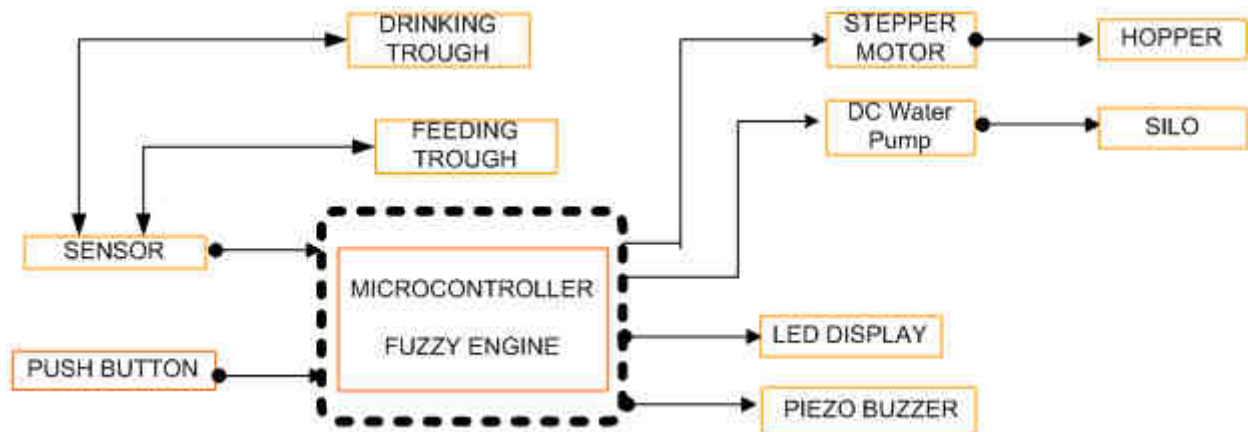

Figure 4: Poultry Control System Block Diagram

4. Hardware Design Consideration

The Microcontroller: The unit was designed around PIC16F877 microcontroller to control the feed dispenser. The chip monitors selected variety of inputs which include digital signal button switches and analogue voltage inputs corresponding to the feed level displacements. The chip responds to these inputs in real time with the use of programmed instructions executed by the in- built processor based on the developed fuzzy rules. The PIC16F877 microcontroller remains one of the most popular microcontrollers. It can execute 200ns instruction, has 256bytes of EEPROM data memory and possesses 40-pins with many internal peripherals [7].

Motor: The motor used for the purpose of this study is stepper motor which is a brushless, synchronous electric motor that converts electrical pulses into mechanical movement. The stepper motor is interfaced by the interfacing circuit in order to communicate with the microcontroller and the fuzzy logic engine. DC water pump operate according to the programs developed with the aid of Fuzzy rules.

Piezo Buzzer: Produces different alarm whenever the feed level reduces or increases.

Sensor: The sensor is a photodiode. Photodiode is a semiconductor device that can be used to detect the presence or absence of light in a system. It has (3) infrared receiver and transmitter hanged on the feeder trough which senses the feed level and sends signal to the microcontroller for its control operation. Figure 5 shows the system overall circuit diagram.

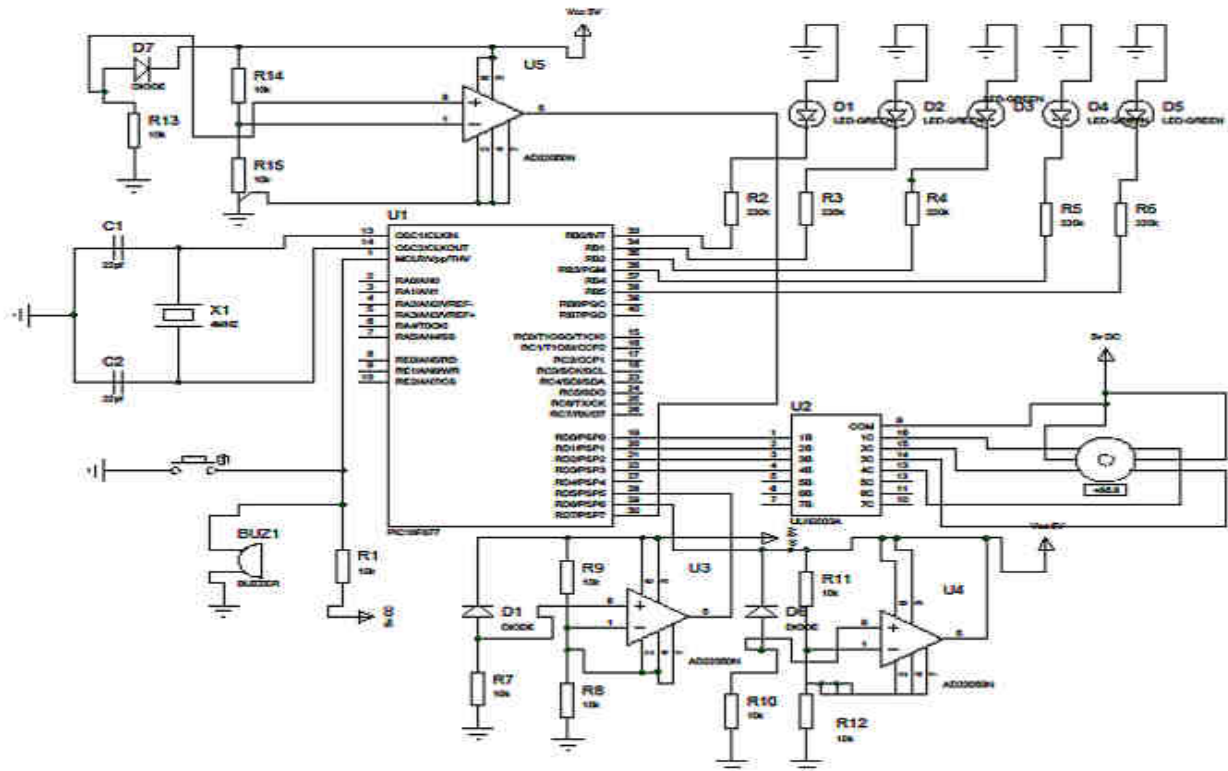

Figure 5. Circuit Diagram of the System

5. Software Design Considerations

As earlier explained fuzzy logic can be described as a problem solving control methodology that can be implemented in systems which ranges from small, simple, networked, multi – channel PC, embedded microcontroller and control systems. The system was designed with fuzzy rule which will be transferred to the Micro C language to be written on the microcontroller during system development phase. This section therefore portrays the steps, definitions and condition needed to design the system fuzzy logic controller, amongst which are:

- A. The control objectives and condition definitions: Defining what to control, Defining what to do in order to control the system, the possible system failure modes and the expected output response definition.
- B. Decide the input and output relationships and pick a minimum number of variables for input to the FL engine (*typically error and rate-of-change-of-error*).
- C. Divide the control problem into series of IF X AND Y THEN Z rules using the rule base structure of the fuzzy logic for the given system input conditions to define the desired system output response.

For the purpose of this study the fuzzy logic controller engine is shown in figure 6 below:

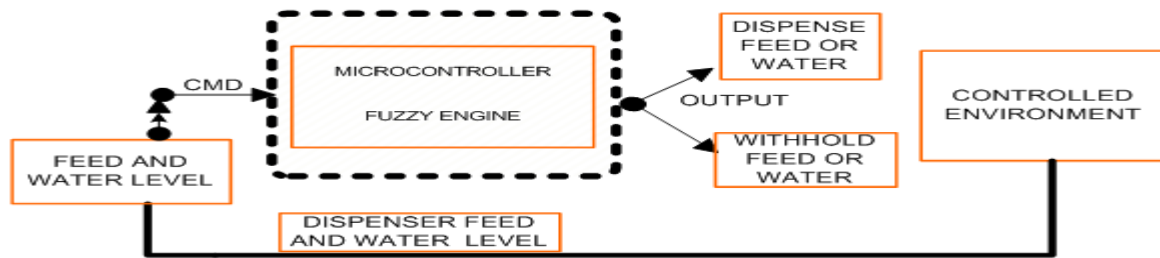

CMD = Target Feed Level
 Feed Level = Sensor feedback in controlled environment
 Error = (+ = too Empty, - = too high
 Rate of Change of Error =(+ = getting High, - = getting Empty)
 Output = DISPENSE, No Change, WITHHOLD

Figure 6. Fuzzy Logic Control Subsystem Block Diagram

6. Fuzzy Logic Controller Design Process For The Feed Dispenser

A. Control Objectives Descriptions: The feed and water level is the control objective for the system. Let Cmd represent target feed and water level (assume 12 kg for feed and 80cl for water); in regard to preprocessing in the fuzzy logic controller this two variables serves as the system input.

The fuzzy logic that is fuzzified and defuzzified resulted in given outputs which are accommodated in the PIC16F877 microcontroller as the main fuzzy engine block.

The post processing stage of the system also known as output response is represented by dispense feed and water and withhold feed and water respectively as shown in figure 4 above. These outputs which are the feed level and water level measured in Kilogram (kg) and Centiliter scale will be tuned to engineering voltage scale equivalence which the microcontroller, the fuzzy engine controller understands.

B. Deciding the Input and Output Variables: By considering the target feed and water level of 12kg and 80cl respectively; that are chosen for the study, the error and rate of change of error are input variables. The error input has 0cl to 80cl for water level and 0kg to 12kg for feed level for positive error, while 80cl to 120cl and 12kg to 20kg are negative error for water and feed level respectively. Thus, -40cl to 80cl and -8kg to 12kg are the possible ranges for error input variable for both the water and feed level, while -120cl to 120cl and -20kg to 20kg are the rate of change of error input variables. The midpoint that exists between error input variable and the rate of change of error is zero.

The dispense feed and water, No change and withhold feed and water are the expected output responses for the system and ranges are clearly stated below:

"N" = "negative" error or error-dot input level

"Z" = "zero" error or error-dot input level

"P" = "positive" error or error-dot input level

"R" = "Reduce feed level" output response

"-" = "No Change" to current output

"I" = "Increase feed level" output response

Error and rate of change of error (error- dot) as been chosen from figure 4 above to be the minimum numbers of possible input product that can be combined for the intelligent feed and water dispenser.

C. Formulation of Fuzzy Rule: From step a and step b, input and definitions are:

INPUT#1: ("Error", positive (P), zero (Z), negative (N))

INPUT#2: ("Error-dot", positive (P), zero (Z), negative (N)) for the feed level and

INPUT#1: ("Error", positive (P), zero (Z), negative (N))

INPUT#2: ("Error-dot", positive (P), zero (Z), negative (N)) for the water level.

CONCLUSION: ("Output", Dispense feed and water (D), No Change (-), Withhold feed and water (W))

INPUT#1 System Status for Feed level

- A. Error = Command - Feedback
- B. P = Too Empty
- C. Z = Just right
- D. N = Too Full

INPUT#1 System Status for water level

- A. Error = Command - Feedback
- B. P = Too Empty
- C. Z = Just right
- D. N = Too Full

INPUT#2 System Status for feed level

- A. Error-dot = $d(\text{Error})/dt$
- B. P = Getting Full
- C. Z = Not changing
- D. N = Getting Empty

INPUT#2 System Status for water level

- A. Error-dot = $d(\text{Error})/dt$
- B. P = Getting Full
- C. Z = Not changing
- D. N = Getting Empt

OUTPUT Conclusion & System Response

Output "D" = Dispense feed and water

Output "-" = don't change anything

Output "W" = Withhold feed and water

Division of control problem into IF X THEN Z rules

For purpose of this study the rule structure for the feed level is thus:

If Cmd-feedlevel = N AND $d(\text{Cmd-feedlevel})/dt = N$ THEN Output = R

If Cmd-feedlevel = Z AND $d(\text{Cmd-feedlevel})/dt = N$ THEN Output = I

If Cmd-feedlevel = P AND $d(\text{Cmd-feedlevel})/dt = N$ THEN Output = I
 If Cmd-feedlevel = N AND $d(\text{Cmd-feedlevel})/dt = Z$ THEN Output = R
 If Cmd-feedlevel = Z AND $d(\text{Cmd-feedlevel})/dt = Z$ THEN Output = NC
 If Cmd-feedlevel = P AND $d(\text{Cmd-feedlevel})/dt = Z$ THEN Output = I
 If Cmd-feedlevel = N AND $d(\text{Cmd-feedlevel})/dt = P$ THEN Output = R
 If Cmd-feedlevel = Z AND $d(\text{Cmd-feedlevel})/dt = P$ THEN Output = R
 If Cmd-feedlevel = P AND $d(\text{Cmd-feedlevel})/dt = P$ THEN Output = I

While the rule structure for the water level is thus:

IF Cmd-WL=N AND $d(\text{Cmd-WL})/dt=N$ THEN output=W
 IF Cmd-WL=Z AND $d(\text{Cmd-WL})/dt=N$ THEN output=W
 IF Cmd-WL=P AND $d(\text{Cmd-WL})/dt=N$ THEN output=D
 IF Cmd-WL=N AND $d(\text{Cmd-WL})/dt=Z$ THEN output=W
 IF Cmd-WL=Z AND $d(\text{Cmd-WL})/dt=Z$ THEN output=NC
 IF Cmd-WL=P AND $d(\text{Cmd-WL})/dt=Z$ THEN output=D
 IF Cmd-WL=N AND $d(\text{Cmd-WL})/dt=P$ THEN output=W
 IF Cmd-WL=Z AND $d(\text{Cmd-WL})/dt=P$ THEN output=D
 IF Cmd-WL=P AND $d(\text{Cmd-WL})/dt=P$ THEN output=D

The rule matrix for feed level rule structure is:

1	R	2	I	3	I
4	R	5	NC	6	I
7	R	8	R	9	I

While the rule matrix for water level rules structure is:

1	W	2	W	3	D
4	W	5	NC	6	D
7	W	8	D	9	D

D. Formulation of Membership Function: The trapezoidal membership functions from the rule structure of the feed and water dispensing system are shown in figure 7, 8, 9 and 10 for both error and rate of change of error input variables.

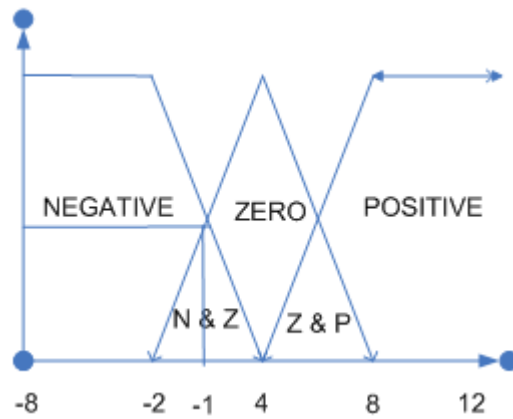

Figure 7. Error Input Membership Function for Feed Level (Error in Kilograms)

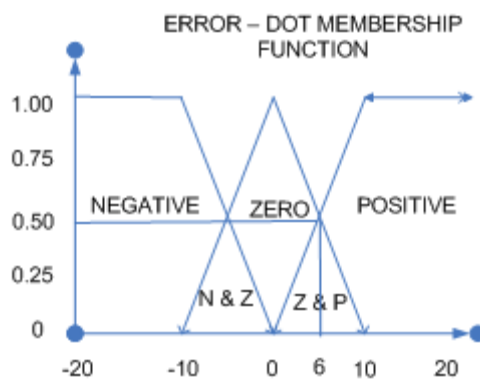

Figure 8. Rate of Change of Error Input Membership Function for Feed Level (Error-Dot in Kilograms)

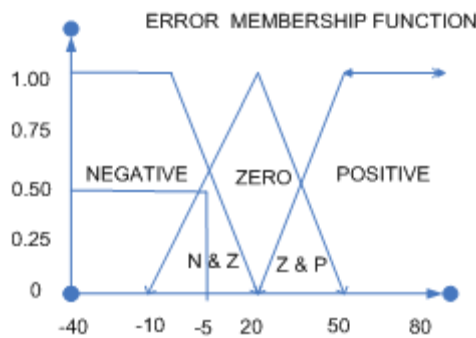

Figure 9. Error Input Membership Function for Water Level (Error in CL)

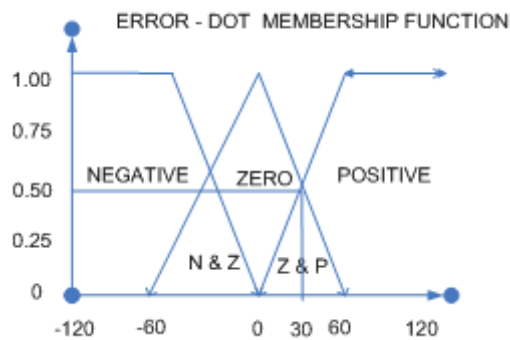

Figure 10. Rate of Change of Error Input Membership Function for Water Level (Error-Dot in CL)

E. Summary of Data for Feed and Water Level: Input Degree of Membership from figure 7 thus is:

"Error" = -1.0, "Negative" = 0.5, "Zero" = 0.5.

While Input Degree of Membership from figure 6 is:

"Error-dot" = +6: "zero" = 0.5 and "positive" = 0.5

"Error" selects rules 1, 2, 4,5,7,8 from the rule matrix while "error-dot" selects rules 4, 6 and 9. Of the nine rules selected, only four (rules 4, 5, 7, 8) fire or have non-zero results. This leaves fuzzy output response magnitudes for only "Dispense" and "No Change" which must be inferred, combined, and defuzzified to return the actual crisp output.

The following definition applies in the rule list below: (e) =error, (er) =error-dot:

If (e < 0) AND (er < 0) then Reduce 0.5 & 0.0 = 0.0

If (e = 0) AND (er < 0) then Increase 0.5 & 0.0 = 0.0

If (e > 0) AND (er < 0) then Increase 0.0 & 0.0 = 0.0

If (e < 0) AND (er = 0) then Reduce 0.5 & 0.5 = 0.5

If (e = 0) AND (er = 0) then No_Chng 0.5 & 0.5 = 0.5

If (e > 0) AND (er = 0) then Increase 0.0 & 0.5 = 0.0

If (e < 0) AND (er > 0) then Reduce 0.5 & 0.5 = 0.5

If (e = 0) AND (er > 0) then Reduce 0.5 & 0.5 = 0.5

If (e > 0) AND (er > 0) then Increase 0.0 & 0 = 0.0.

While for water level is:

"error" = -20cl: "negative" = 0.5 and "zero" = 0.5

"error-dot" = +30cl: "zero" = 0.5 and "positive" = 0.5

Now referring back to the rules, plug in the membership function weights from above. "Error" selects rules 1, 2, 4,5,7,8 while "error-dot" selects rules 4 through 9. "Error" and "error-dot" for all rules are combined to a logical product (LP or AND, that is the minimum of either term). Of the nine rules selected, only four (rules 4, 5, 7, and 8) fire or have non-zero results. This leaves fuzzy output response magnitudes for only "withhold" and "No_Change" which must be inferred, combined, and defuzzified to return the actual crisp output.

The following definitions applies in the rule list below: (e)=error, (er)=error-dot:

If (e < 0) AND (er < 0) then Withhold 0.5 & 0.0 = 0.0

If (e = 0) AND (er < 0) then Dispense 0.5 & 0.0 = 0.0

If (e > 0) AND (er < 0) then Dispense 0.0 & 0.0 = 0.0

If (e < 0) AND (er = 0) then Withhold 0.5 & 0.5 = 0.5

If (e = 0) AND (er = 0) then No_Chng 0.5 & 0.5 = 0.5

If (e > 0) AND (er = 0) then Dispense 0.0 & 0.5 = 0.0

If (e < 0) AND (er > 0) then Withhold 0.5 & 0.5 = 0.5

If (e = 0) AND (er > 0) then Withhold 0.5 & 0.5 = 0.5

If (e > 0) AND (er > 0) then Dispense 0.0 & 0 = 0.0

F. Inference: This is the method used to determine the firing strength of each rule of the system. By comparing the membership function and the rule matrix in above design only rule 4,5,7 and 8 fire at 50% while rule 1, 2, 3, 6 and 9 do not fire at all(0%).

The logical products for each rule will be combined or inferred (max-min'd, maxdot'd, averaged, root-sum-squared, etc.) before being passed on to the defuzzification process for crisp output generation. The horizontal coordinate of the "fuzzy centroid" of the area under that function is taken as the output. In this study, the ROOT-SUM-SQUARE (RSS) method is adopted. The RSS method combines the effects of all applicable rules, scales the functions at their respective magnitudes, and computes the "fuzzy" centroid of the composite area.

G. Defuzzification: This is the changing fuzzy set result to a number that can be sent to the process as a control signal. Based on the Input Degree of Membership from figure 5 and figure 6 earlier used for feed level figure 7 and 8 for water level; an error of 1.0 and an error-dot of +6 selects regions of the "negative" and "zero" output membership functions for the feed, while an error of -20 and an error-dot of +30 selects regions of the "negative" and "zero" output membership functions for water. The respective output membership function strengths for both feed and water level (range: 0-1 i.e. y-axis) from the possible rules (R1-R9) are:

“Negative“ or Dispense Output = $(R1^2 + R4^2 + R7^2 + R8^2) = (0.00^2 + 0.50^2 + 0.50^2 + 0.50^2)^{.5} = 0.866$ “

Zero“ or No Change Output = $(R5^2)^{.5} = (0.50^2)^{.5} = 0.500$

“Positive“ or Withhold Output = $(R2^2 + R3^2 + R6^2 + R9^2) = (0.00^2 + 0.00^2 + 0.00^2 + 0.00^2)^{.5} = 0.000$ and that of water is:

“Negative“ or Dispensing Output = $(R1^2 + R4^2 + R7^2 + R8^2) = (0.00^2 + 0.50^2 + 0.50^2 + 0.50^2)^{.5} = 0.866$

“Zero“ or No Change Output = $(R5^2)^{.5} = (0.50^2)^{.5} = 0.500$

“Positive“ or Withhold Output = $(R2^2 + R3^2 + R6^2 + R9^2) = (0.00^2 + 0.00^2 + 0.00^2 + 0.00^2)^{.5} = 0.000$

The fuzzy logic centroid equation for both feed and water level is represented below:

Formula: $OUTPUT = (neg_center * neg_strength + zero_center * zero_strength + pos_center * pos_strength) / (neg_strength + zero_strength + pos_strength)$

$(-100 * 0.866 + 0 * 0.500 + 100 * 0.000) / (0.866 + 0.500 + 0.000) = - 63.4\%$.This output result is generated based on the input degree of member ship function from figure 5, 6, 7 and figure 8 earlier used. This shows that the feedback has exceeded the command and the feed and water are still dispensing, therefore withholding the feed level by the positive value (i.e. 63.4%) of the output result is required.

7. Conclusion

An attempt was made in this study to improve on the limitations of the existing feed and water dispensing systems. The study has therefore presented an intelligent feed and water dispensing system using fuzzy logic control technique. After the final development of the proposed design, this anticipated system shall be capable of dispensing more feed inside the feeding trough by sensing the feed level as the level reduces and for reduced intensive manual labour exerted in the poultry farming with corresponding increase in cost benefits and high profit yield. It will also help the poultry farm in maintaining a good hygiene.

8. Future Work

In future, the fuzzy logic controller designed for our dispensing system would be improved upon for mobility while dispensing prior to implementation and development on appropriate sensors and microcontroller systems for improved cost benefits and minimal human intervention in deep litter poultry feeding system

References

- [1] Adedinsewo, O (2004), “Design and construction of a computer controlled poultry feed Dispenser and temperature regulator”, B. Tech. Thesis, Department of Computer Science and Engineering, Ladoko Akintola University of Technology, Ogbomosho, Nigeria.
- [2] Anne *et al.*, (2001), “Research on Automatic Feeding Systems for Dairy cattle”. Macmillian, London.
- [3] Arulogun, O.T, O.M Olaniyi, O.A Oke and D.O. Fenwa (2010), “Development of mobile Intelligent Poultry Feed and Water Dispensing System”, Medwell journals of Engineering and Applied Science, Volume 5(3), Pp 229 – 233.
- [4] ChuenChien Lee (1990), “Fuzzy Logic in Control Systems: Fuzzy Logic Controller”, IEEE Transaction on Systems, Man and Cybernetics, Volume 20, No. 2.
- [5] Hill, G., E. Horstkotte and J. Teichrow, 1990. Fuzzy-C development system-user’s manual, TogaiInfraclogic, 30 Corporate Park, Irvine, CA 92714, USA.
- [6] Jan Janzten (1998), “Design of Fuzzy Controllers”, Retrieved online at <http://faculty.petra.ac.id/resmana/private/fuzzy/design.pdf> on 17th April 2013.
- [7] Joseph, B., 2006. Paradigm Shift: An introduction to fuzzy logic. IEEE potentials.
- [8] Odunsi, A (2010), “A practical Approach to Animal production and Health”, Oluseyi Press, Ibadan, pp 30 – 31.
- [9] Oluayemi, J.A. and F.A. Robert, 1986. Poultry Production in Warm Wet Climate. Macmillian, Nigeria.

- [10] Omosebi, B, (2006), “Development of a self-propelled poultry feed dispenser with Feed level detector”, B. Tech. Thesis, Department of Computer Science and Engineering, LadokeAkintola University of Technology, Ogbomosho, Nigeria.
- [11] Sainsbury, D, (2000), “Poultry health and Management (Chicken, Turkeys, Ducks Geese and Quail)”, Blackwell Publishing, Great Britain.
- [12] Steven D. Kaehler, (1991), “Europe get into Fuzzy Logic”, Electronics Engineering time.

The IISTE is a pioneer in the Open-Access hosting service and academic event management. The aim of the firm is Accelerating Global Knowledge Sharing.

More information about the firm can be found on the homepage:
<http://www.iiste.org>

CALL FOR JOURNAL PAPERS

There are more than 30 peer-reviewed academic journals hosted under the hosting platform.

Prospective authors of journals can find the submission instruction on the following page: <http://www.iiste.org/journals/> All the journals articles are available online to the readers all over the world without financial, legal, or technical barriers other than those inseparable from gaining access to the internet itself. Paper version of the journals is also available upon request of readers and authors.

MORE RESOURCES

Book publication information: <http://www.iiste.org/book/>

IISTE Knowledge Sharing Partners

EBSCO, Index Copernicus, Ulrich's Periodicals Directory, JournalTOCS, PKP Open Archives Harvester, Bielefeld Academic Search Engine, Elektronische Zeitschriftenbibliothek EZB, Open J-Gate, OCLC WorldCat, Universe Digital Library, NewJour, Google Scholar

