

Power Balance Theory Control of an Integrated Electronic Load Controller with Zig-Zag Transformer for Stand-Alone Wind Farm with PV Array Connected to Three-Phase Four-Wire Load

Dipesh Kumar Karmakar¹ Laxman Dasari¹ Kapavarapu.M.R.Phani Swaroop¹ N.G.S Raju²
1.M.Tech Student, EEE Department, GITAM University, Visakhapatnam, Andhra Pradesh-530045, INDIA
2.2 Assistant Professor, EEE Department, GITAM University, Visakhapatnam, Andhra Pradesh-530045, INDIA

Abstract

Wind Turbine (WT) with PV array power generation attracted attention to supply electricity in remote areas because of its self-sustainability, environment friendly and economic reasons. This paper propounds isolated Wind turbine and PV array generating system with MPPT, DC-DC boost converter, Integrated electronic load controller (IELC) feeding three-phase four-wire non-linear loads. The power balance theory (PBT) is applied to estimate the reference load current to control the six-leg voltage source converter (VSC). The IELC is realized with zig-zag/three single-phase transformer and a six-leg insulated-gate bipolar-transistor-based current-controlled voltage source converter, a chopper switch and auxiliary load on DC bus. The fuel cell power generating system is modeled and simulated in MATLAB environment using Simulink and sim power system (SPS).

Keywords: Wind Farm(WF), Wind Turbine(WT), PhotoVoltaic cell (PV), Power balance theory(PBT), Integrated electronic load controller (IELC), Voltage source converter(VSC), Maximum Power Point Tracking(MPPT).

Introduction

Renewable Energy is the most important necessity, as demand for energy is briskly escalating; the non-renewable energy resources are depleting and costly to sustain the growing energy demand. The power generated from Wind and Solar is one among the safe, clean, economical, technically efficient and environmental friendly method to serve the growing load demands [1].

Photovoltaics are the process of converting sunlight directly into electricity using PV cells. Today it is a rapidly growing and increasingly important renewable alternative to conventional fossil fuel electricity generation, but compared to other electricity generating technologies, it is a relative newcomer. Power electronic interfacing circuit is called power conditioning unit. It is must for PV based systems to condition its output dc voltage. It converts the dc voltage to ac voltage. The PV source is connected to the load or grid through inverter which must be interfaced with the grid in terms of voltage and frequency [2]. The DC bus voltage of the voltage source converter of integrated electronic load controller is less sensitive to load fluctuations. The PBT based control of the proposed system is applied to derive the reference load currents to get power quality improvement [3][4]. The six-leg voltage source converter operates as harmonic eliminator and load balancer. The zigzag transformer eliminates zero-sequence currents and triplen harmonics in the primary winding itself by keeping the secondary winding free from triplen harmonics and zero-sequence currents. Thereby reducing device rating of voltage source controller. This scheme is simulated under the MATLAB environment using simulink and power system blockset toolboxes, and the results are verified by implementation of control scheme. The performance of the proposed scheme is demonstrated through simulation results.

Description of PV Cell

Solar photovoltaic (PV) sources are among the promising RESs as they can be installed in every location and require little maintenance effort. Maximum power point tracking (MPPT) can be used for wind turbines and PV solar systems to maximize power output, in this paper it is used for PV system only. PV solar systems exist in many configurations, the basic configuration sends power from collector panels to the DC-AC inverter, and from there directly to the electrical grid. A second version, called a hybrid inverter, might split the power at the inverter, where a percentage of the power goes to the grid and the remainder goes to a battery bank. The third version is not connected at all to the grid but employs a dedicated PV inverter that features the MPPT. In this configuration, power flows directly to a load. This allegedly increases PV solar efficiency by up to 20%.

MPPT or Maximum Power Point Tracking is algorithm that included in charge controllers used for extracting maximum available power from PV module under certain conditions. The voltage at which PV module can produce maximum power is called 'maximum power point' (or peak power voltage). Maximum power varies with solar radiation, ambient temperature and solar cell temperature.

PV cells always exhibits complex relationship between temperature and total resistance resulting a non-linear output efficiency which can be examined based on the I-V curve. It is the purpose of the MPPT system to sample the output of the PV cells and apply the proper resistance (load) to obtain maximum power for any given environmental conditions. MPPT instruments are basically integrated into an electric power converter device,

which gives voltage or current conversion, filtering, and regulation for driving various consumer loads.

Description of Wind Farm

A wind farm consisting of three 1.5-MW wind turbines is connected to non-linear load. The wind farm is simulated by three pairs of 1.5 MW wind-turbines. Wind turbines use squirrel-cage induction generators (IG). The stator winding is connected directly to the 50 Hz grid and the rotor is driven by a variable-pitch wind turbine. The pitch angle is controlled in order to limit the generator output power at its nominal value for winds exceeding the nominal speed (9 m/s). In order to generate power the IG speed must be slightly above the synchronous speed. Speed varies approximately between 1 pu at no load and 1.005 pu at full load. Each wind turbine has a protection system monitoring voltage, current and machine speed.

Reactive power absorbed by the IGs is partly compensated by capacitor banks connected at each wind turbine low voltage bus (400 kvar). The turbine mechanical power as function of turbine speed is displayed for wind speeds ranging from 4 m/s to 10 m/s. The nominal wind speed yielding the nominal mechanical power (1pu=3 MW) is 9 m/s. The wind turbine model that allow transient stability type studies with long simulation time.

Control Strategy

The basic equations of this control algorithm are as follows

A. In-phase component of reference source currents

$$V_t = \{(2/3)(V_{sa}^2 + V_{sb}^2 + V_{sc}^2)\}^{1/2} \quad (1)$$

Where, V_{sa} , V_{sb} , V_{sc} are the three phase voltages at load terminals.

The unit vector in phase with v_a, v_b, v_c is calculated as

$$u_{sa} = v_a/V_t \quad u_{sb} = v_b/V_t \quad u_{sc} = v_c/V_t \quad (2)$$

Where, u_{sa} , u_{sb} , u_{sc} are unit vector in phase.

The instantaneous active power of the consumer loads is derived as

$$P_L = (V_{sa} i_{La} + V_{sb} i_{Lb} + V_{sc} i_{Lc}) \quad (3)$$

The amplitude of the fundamental active power component of the load current is calculated as

$$I_{Lactive} = (2/3)(P_L/V_t) \quad (4)$$

The error in the dc bus voltage of the voltage source converter ($V_{dcer(n)}$) of the integrated electronic load controller at n th sampling instant is

$$V_{dcer(n)} = V_{dc(n)}^* - V_{dc(n)} \quad (4)$$

Where,

$V_{dc(n)}^*$ is the reference dc voltage

$V_{dc(n)}$ is the sensed dc-link voltage

The output of the PI controller to regulate the dc link voltage of voltage source converter at the n th sampling instant

$$I_{loss(n)} = I_{loss(n-1)} + K_{pd}\{V_{dcer(n)} - V_{dcer(n-1)}\} + K_{id}V_{dcer(n)} \quad (5)$$

Where $I_{loss(n)}$ is considered as part of the active-power component of the load current. K_{pd} and K_{id} are the proportional and integral gain constants of the DC link PI voltage controller.

Therefore, total an active power component of the load currents (I_{active}^*) and is calculated by adding to the DC component ($I_{Lactive}$) of the load currents and output DC link voltage controller, $I_{loss(n)}$

$$I_{active}^* = I_{Lactive} + I_{loss} \quad (6)$$

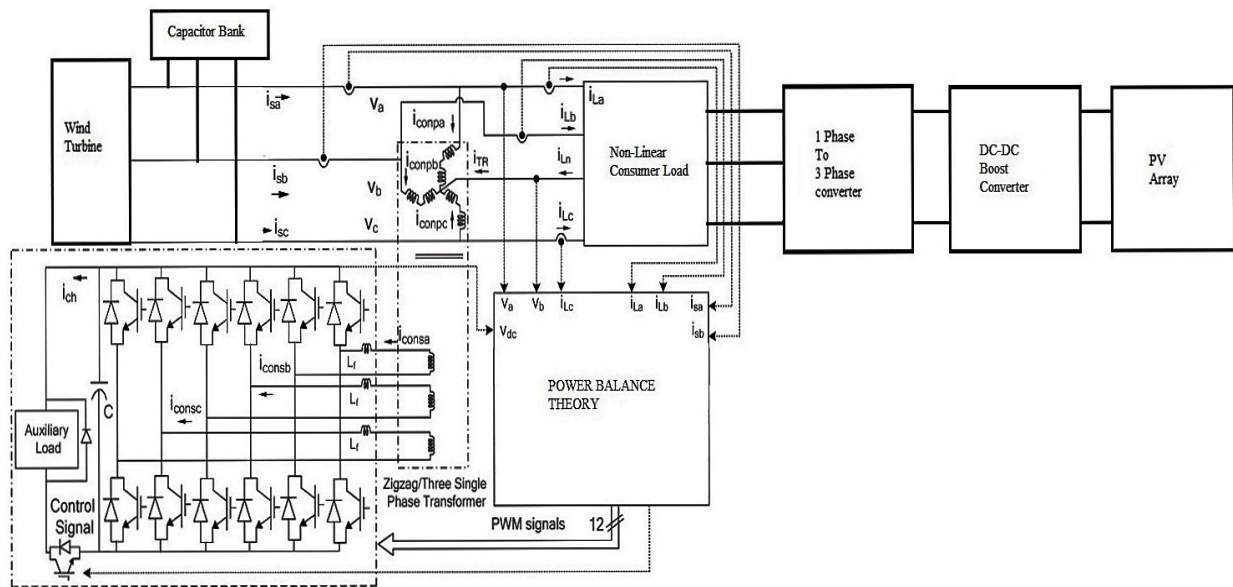

Fig. 1. Schematic configuration of Wind Farm and PV Array with MPPT, DC-DC Boost converter and IELC

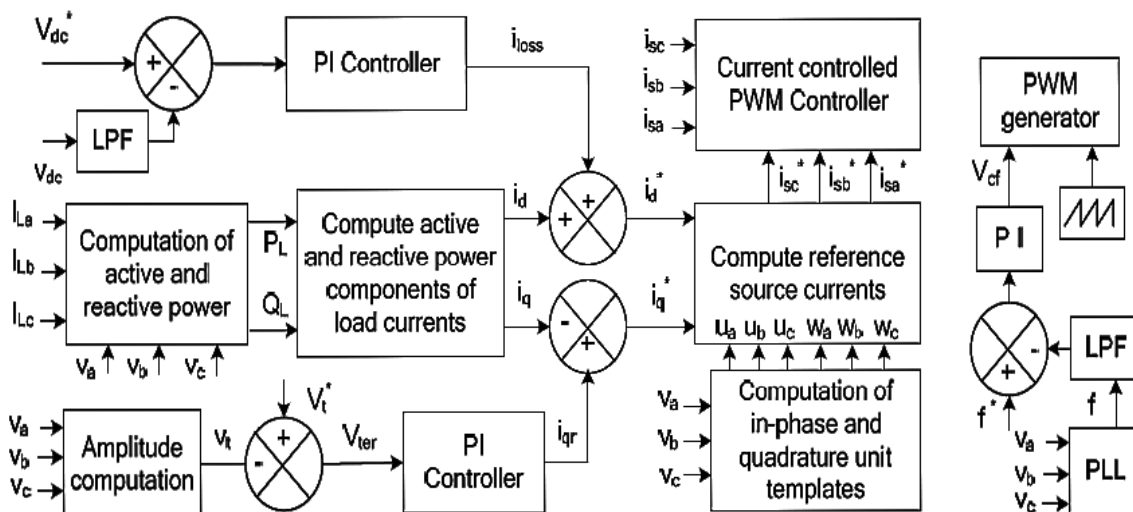

Fig.2. Power Balance Theory Control Algorithm

The fundamental components active-power of the reference instantaneous load currents in phase with PCC voltages are derived as,

$$I_{sad}^* = I_{active}^* \cdot u_{sa} \quad I_{sbd}^* = I_{active}^* \cdot u_{sb} \quad I_{scd}^* = I_{active}^* \cdot u_{sc} \quad (7)$$

B. Quadrature Components of Reference Source Currents

The unit vector in quadrature with v_a, v_b, v_c are derived using quadrature transformation of the in-phase unit vectors u_{sa}, u_{sb}, u_{sc} .

$$w_{sa} = -u_{sb}/\sqrt{3} + u_{sc}/\sqrt{3} \quad (8)$$

$$w_{sb} = \sqrt{3} u_{sa}/2 + (u_{sb} - u_{sc})/2\sqrt{3} \quad (9)$$

$$w_{sc} = -\sqrt{3} u_{sa}/2 + (u_{sb} - u_{sc})/2\sqrt{3} \quad (10)$$

The PI voltage controller is used to regulate the PCC voltage. The amplitude of terminal voltage (V_t) is derived in eq(9) and reference value (V_{ref}) is fed to the PI voltage controller. The voltage error is derived as,

$$V_{er(t)} = V_{ref(t)}^* - V_{t(t)} \quad (11)$$

The output of the PI controller, $I_{qr(n)}^*$ for maintaining the AC terminal voltage to a constant value at the n^{th} instant is,

$$I_{qr(n)}^* = I_{qr(n-1)}^* + K_{pa} \{V_{er(n)} - V_{er(n-1)}\} + K_{ia} V_{er(n)} \quad (12)$$

Where,

K_{pa} and K_{ia} are the proportional and integral gain constants of the PI controller

$V_{er(n)}$ and $V_{er(n-1)}$ are the error in voltages of n^{th} and $(n-1)^{\text{th}}$ instants.

$I_{qr(n-1)}^*$ is the amplitude of the quadrature component of the reference fundamental current at $(n-1)^{\text{th}}$ instant.

The instantaneous reactive power of the consumer load is derived as

$$Q_L = (1/3) \{ (V_{sa} - V_{sb})i_{La} + (V_{sb} - V_{sc})i_{Lb} + (V_{sc} - V_{sa})i_{Lc} \} \quad (13)$$

This instantaneous reactive power consists of both DC and AC components.

The amplitude of fundamental reactive power of the load current is given by

$$I_{L\text{reactive}} = (2/3)(Q_L/V_t) \quad (14)$$

The instantaneous quadrature component of the reference load currents are derived as,

$$I_{sad}^* = I_{\text{active}}^* W_{sa}, I_{sbd}^* = I_{\text{active}}^* W_{sb}, I_{scd}^* = I_{\text{active}}^* W_{sc} \quad (15)$$

C. Reference source currents

The total reference source currents are the sum of the in-phase and the quadrature components of the reference source currents as

$$i_{sa}^* = i_{sad}^* + i_{saq}^* \quad (16)$$

$$i_{sb}^* = i_{sbd}^* + i_{sbq}^* \quad (17)$$

$$i_{sc}^* = i_{scd}^* + i_{scq}^* \quad (18)$$

These amplified current-error signals are compared with fixed-frequency (10-kHz) triangular wave to generate unipolar PWM switching signals to generate the gating signals for the six-leg VSC (each phase consists of three H-bridge VSCs) of the IELC. For switching on the H-bridge VSC of phase ‘‘a,’’ the basic logic is

$V_{cca} > V_{tri}$ (upper device of the left leg of phase a on)

$V_{cca} \leq V_{tri}$ (lower device of the left leg of phase a on) (19)

$-V_{cca} > V_{tri}$ (upper device of the left leg of phase a on)

$-V_{cca} \leq V_{tri}$ (lower device of the left leg of phase a on) (20)

Where, V_{tri} is taken as the instantaneous value of the fixed- frequency triangular wave and a similar logic are applied to generate the gating signals for the other two phases.

D. Chopper PWM Controller

The frequency error of the three-phase voltages at load terminal is defined as

$$f_{er(n)} = f_{(n)}^* - f_{(n)} \quad (21)$$

Where, f^* is the reference frequency (50 Hz in the present system) and ‘‘ f ’’ is the frequency of the load voltage.

The instantaneous value of f is estimated using the phase-locked loop over the ac terminal voltages (v_a , v_b , and v_c), as shown in Fig. 3.

At the n^{th} sampling instant, the output of the frequency PI controller is

$$V_{cf(n)} = V_{cf(n-1)} + K_{pf} \{ f_{er(n)} - f_{er(n-1)} \} + K_{if} f_{er(n)} \quad (22)$$

This output of the frequency controller $V_{cf(n)}$ is compared with the fixed-frequency triangular carrier wave (3 kHz in this case) to generate the gating signal of the insulated-gate bipolar transistor (IGBT) of the chopper of integrated electronic load controller.

matlab based modeling

The load interfaced Wind Farm and PV array power generating system is modeled using MATLAB/Simulink. The three-phase four wire non-linear load is connected to six- leg voltage source converter VSC through zigzag transformer along with Wind Farm is simulated in MATLAB as shown in fig(1). The control algorithm for the power balance theory PBT is also modeled in MATLAB. Three-phase reference non-linear load currents are derived from the measured PCC voltages (V_{sa}, V_{sb}, V_{sc}) and load currents ($I_{Lsa}, I_{Lsb}, I_{Lsc}$) and DC link voltage of the chopper (V_{dc}). The simulation of the proposed system is carried out on the MATLAB version 7.9.0 (R2009b) using the sim power system (SPS) toolbox and discrete step solver of 5e-6.

results and discussion

Simulation results of the Wind Farm along with PV array power generating system is shown in Fig.3a-3b. The Wind Farm along with PV cell power generating system is controlled by power balance theory (PBT) for non-linear loads. Performance of the proposed system is represented in terms of PV cell voltage (V_{FC}), DC bus voltage (V_{dc}), DC bus current (I_{dc}), load current (I_{labc}), active (P) and reactive (Q) power, PV array power (P_{FC}), PV array current (I_{FC}), load voltage (V_{labc}).

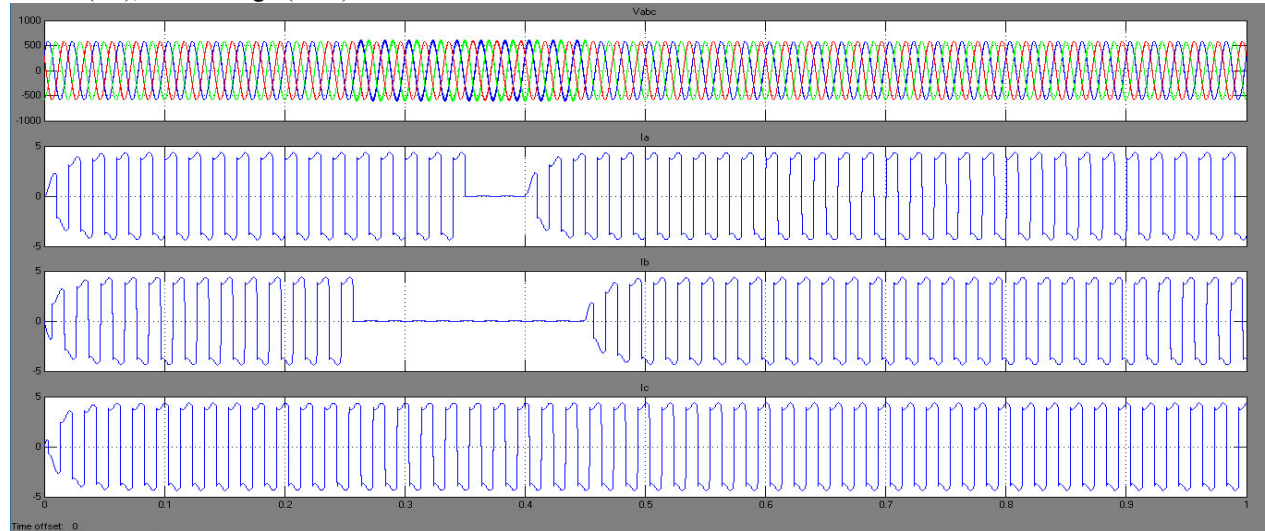

Fig. 3(a). Performance of the proposed system for non-linear load

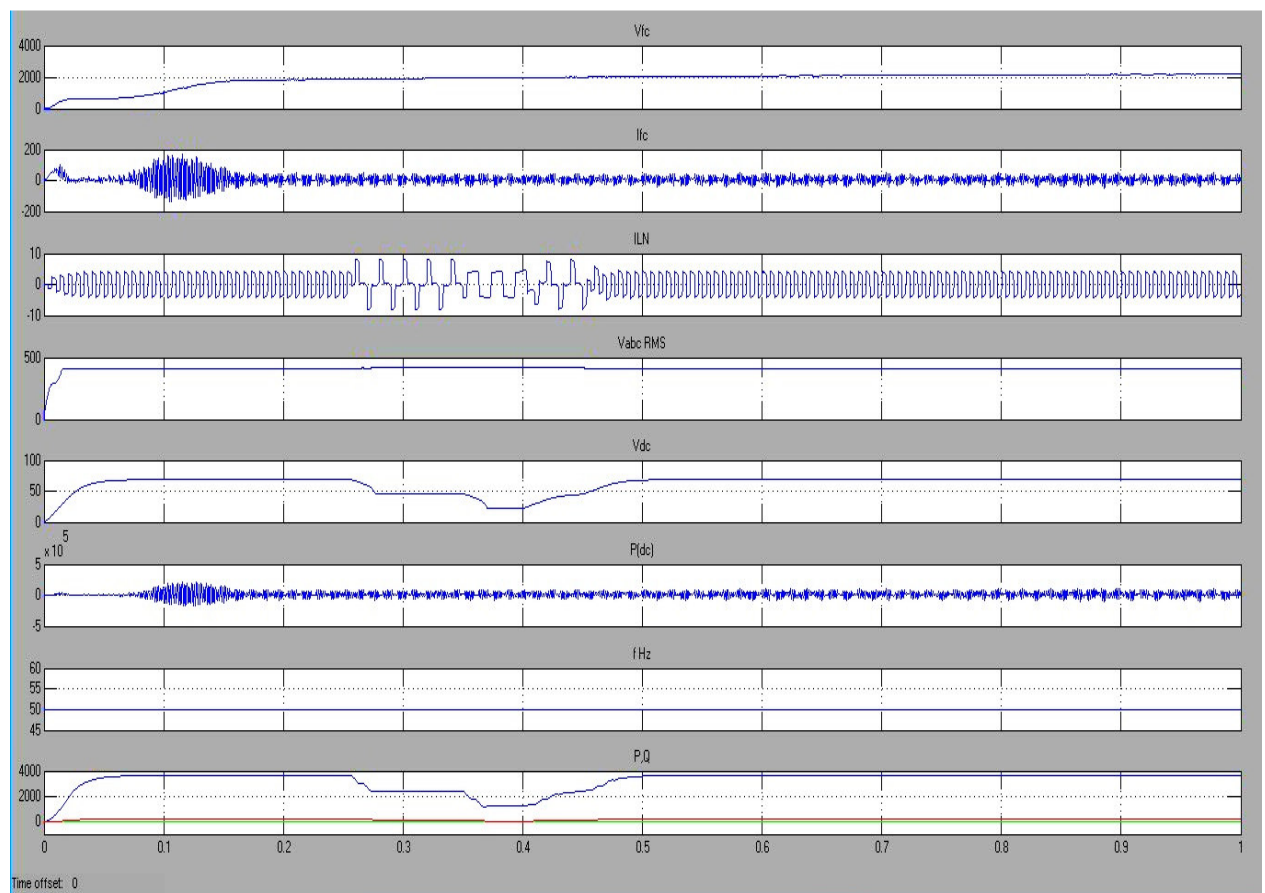

Fig. 3(b). Performance of the proposed system for non-linear load

Conclusion

The stand-alone Wind Farm with PV cell array is modelled and its performance with power balance theory based control algorithm of an integrated electronic load controller is studied. The performance of the propounded system

is studied under non-linear load condition. It was observed that the system performance is satisfactory with proposed integrated electronic load controller with PBT based control algorithm. This controller is simple to operate, easy to design and less sensitive to load perturbation.

REFERENCES

- [1] B. K. Bose, "Energy environment, and advances in power electronics," *IEEE Transactions on Power Electronics*, vol. 15, no. 4, 2000 pp.699-701.
- [2] Remus Teodorescu, Marco Liserre and Pedro Rodriguez, "*Grid Converters for photovoltaic and wind power system*," John Wiley & Sons, Ltd, The Atrium, Southern Gate, Chichester, West Sussex, United Kingdom. 2011.
- [3] B. Singh, K. Al-Haddad and A. Chandra, "A New Control Approach to Three-Phase Active Filter for harmonics and Reactive power Compensation," *IEEE Trans. Power Sys.*, vol. 13, no. 1, pp. 133-138, Feb.1998.
- [4] B. N. Singh, B Singh, A Chandra and K Al-Haddad, "Design and digital implementation of active filter with power balance theory", *IEE Proc.*vol. 152, no. 5, pp. 1149 - 1160, Sep 2005.
- [5] G. K. Kasal and B. Singh, "Decoupled voltage and frequency controller for isolated asynchronous generators feeding three-phase fourwire loads," *IEEE Trans. Power Del.*, vol. 23, no. 2, pp. 966–973, Apr. 2008.
- [6] I. Serban, C. P. Ion, C. Marinescu, and M. N. Cirstea, "Electronic load controller for stand-alone generating units with renewable energy sources," in *Proc. IEEE IECON*, Paris, France, Nov. 2006, pp. 4309–4312.
- [7] B. Singh, S. S. Murthy, and S. Gupta, "A stand-alone generating system using self-excited induction generators in the extraction of petroleum products," *IEEE Trans. Ind. Appl.*, vol. 46, no. 1, pp. 94–101, Jan./Feb. 2010.
- [8] B. Singh, P. Jayaprakash, T. R. Somayajulu, and D. P. Kothari, "Reduced rating VSC with a zig-zag transformer for current compensation in a threephase four-wire distribution system," *IEEE Trans. Power Del.*, vol. 24,no. 1, pp. 249–259, Jan. 2009.
- [9] Dipesh Kumar Karmakar, Laxman Dasari, N.G.S Raju "Stand-Alone Wind Power Generation using Adaline Based Integrated Electronic Load Controller," *Control Theory and Informatics* ISSN 2224-5774 (Paper) ISSN 2225-0492 (Online) Vol.5, No.6, 2015