

Grid Computing: A Desirable Tool for Electronic Governance

D. G. Iyanda, (Corresponding Author)

Department of International Co-operation, State Planning Commission of Osun,
New Secretariat, P. M. B. 4435, Osogbo, Nigeria.
Tel. Phone: 0806-634-6384 E-mail: dgiyanda@fastmail.fm

L.A. Ogundele,

Department of Computer Science, Osun State College of Education, Ilesa, Osun State, Nigeria.
Tel. Phone: 0806-231-2269 E-Mail: lukman_ogundele@yahoo.com

O.A. Oyedemi

Department of Computer Science, Osun State College of Education, Ilesa, Osun State, Nigeria.
Tel. Phone: 0803-444-4532 E-Mail: nikkyem@yahoo.com

Abstract

This paper explained how Government at different levels can apply Information and Communication Technology (ICT) to achieve efficiency, effectiveness, transparency and accountability in Government to Government (G2G), Government to Employee (G2E), Government to Citizen (G2C) and Government to Business (G2B). This application is referred to as Electronic Governance (e-Governance). The system enables citizens to make best use of automated administration processes that are accessible on-line. Grid computing is an ideal solution to this type of administrative processes. This paper therefore presents how Grid computing can be used to effectively and efficiently meet the yearnings of citizenry.

In this paper, we demonstrated the creation of a virtual environment by using Grid technologies to a specific e-governance application on distributed resources. We presented a framework for the adoption of grid computing for e-governance management using Electronic Bill server (EB server), Comprehensive Welfare and Social Services server (CWSS server) and Corporation sever (C server). Experiments were run with the Grid environment and without Grid environment by considering the number of jobs completed and the period to complete various jobs submitted for processing using MATLAB.

The number of jobs completed by EB server by using Grid: are 20, 40, 60, 80,100 and 120 while 15, 25, 33, 60, 72 and 90 were completed without Grid under the same condition. The numbers of jobs completed by CWSS server with Grid are: 30,50,70,90,120 and 130 while 22.5, 37.5, 52.5, 67.5 90 and 97.5 were completed without Grid. The numbers of jobs completed by Corporation server under Grid are: 30,50,70,90,120 and 130 while 24, 40,56,72,96 and 104 were completed without Grid. The period to complete various jobs submitted for processing by the EB serve under Grid are: 18,30, 42,54,72 and 88minutes while 30,50,70,90,120 and 130minutes were required without Grid. For CWSS server, the period to complete various jobs submitted for processing under Grid are: 6.5,19.5,32.5,45.5,58.5,78 and 84.5 minutes while 10, 30,50,70,90,120 and 130minutes were required without Grid. For Corporation server, the period to complete various jobs submitted for processing under Grid are: 6.4,19.2,32,44.8,57.6, 76.8 and 82.2minutes while 10,30,50,70,90 120, and 130minutes were required without Grid.

The result of simulation revealed that implementing an e-Governance solution was cost effective, efficient, consistent and reduced job processing time with high quality of result and providing better services to citizens.

Key words: E-Governance, Grid Applications, Grid Computing, Grid environment, Grid Infrastructure and Grid Resource Broker

INTRODUCTION

Grid computing generally refers to an infrastructure that involves the integrated and collaborative use of all computing resources into a single virtual computing environment. Grid applications often involve large amounts of data and/or computing resources that require secure resource sharing across organizational boundaries. With particular reference to Rajkumar et al (2005), Rajkumar and Murshed (2002), the key components of a Grid are: Grid frame work, Core Grid Middleware, User-Level Grid Middleware, and Grid Applications and Portals.

The Grid frame work consists of all the globally distributed resources that are accessible from anywhere on the Internet. These resources could be computers running a variety of operating systems as well as resource management systems such as Load Sharing Facility, databases and special scientific instruments such as a radio telescope. The Core Grid Middleware is a platform that offers core services such as remote process management, co allocation of resources, storage access, information registration and discovery, security and

aspects of Quality of Service (QoS) such as resource reservation and trading, managing resources and scheduling application tasks for execution on global resources. The User-Level Grid Middleware includes application development environments, programming tools and resource brokers for users. The Grid Applications and Portals are typically developed using Grid-enabled languages and utilities such as message-passing interface or parameter specification language.

Following from Abramson et al (1995), Computational Grids enable sharing a wide variety of geographically distributed resources including supercomputers, storage systems, data sources and specialized devices owned by different organizations to create virtual enterprises and organizations. They allow selection and aggregation of distributed resources across multiple organizations for solving large-scale computational and data intensive problems in science, engineering and commerce. The parallel processing of applications on distributed systems provide scalable computing power. This enables exploration of large problems with huge data sets, which is essential for creating new insights into the problem. Citizen applying for a new free health care scheme is one of the e-governance applications that require large computational and data storage capability.

The ultimate success of Computational Grids as a production-oriented commercial platform for solving problems can be utilized to support e-governance applications. In a Grid environment, a set of resources can dynamically team up to solve a given problem. This type of mutually agreed teaming up is quite useful for developing computational e-governance applications for executing parallel application tasks that have high degree of message communications for sharing partial results. Detailed discussion of the broker implementation using the GridSim toolkit is available in Rajkumar and Murshed (2002). The key components of the broker are: Interface, resource discovery and scheduling, scheduling flow manager, dispatcher and gridlets receptor.

Previous Related Works

Numerical problem solving environment for scientists which supports Data Grid features through the use of MPICH-G and globus was presented in Allen (2000). Application-Level Scheduling project builds agents for each application responsible for offering a scheduling mechanism Berman and Wolski (1997). This uses a system-centric scheduling policy, which is targeted at minimizing the completion time and it does not take account of the economic cost of jobs processing into consideration while selecting applications. In the Data Grid Applications, the Storage Resource Broker from San Diego Supercomputing Centre provides middleware for storing datasets and accessing them, Baru et al(1998). It was observed that it does not deal with application execution directly. Similar to Berman and Wolski (1997), Baru et al (1998) and Allen (2000), this paper focuses on a resource scheduling strategy within a Data Grid. However, in this paper we concentrate on heterogeneous resources for simulation purpose. This is the major different from other related works and this paper.

E-governance Architecture

As indicated in Rajkumar et al (2005), the design features that are required by a Grid to provide users with a perfect computing environment has four main features. These are: Multiple Administrative, Domains and Autonomy, Heterogeneity, Scalability and Dynamicity or Adaptability. However, the steps necessary to realize a Grid include the integration of individual software and hardware components into a combined resource. It also involved the deployment of Low-level middleware to provide a secure and transparent access to resources. Other features include; User-level middleware and tools for application development and the aggregation of distributed resources and the development and optimization of distributed applications to take advantage of the available resources and infrastructure. Figure 1 below is the layered Grid architecture with a number of components.

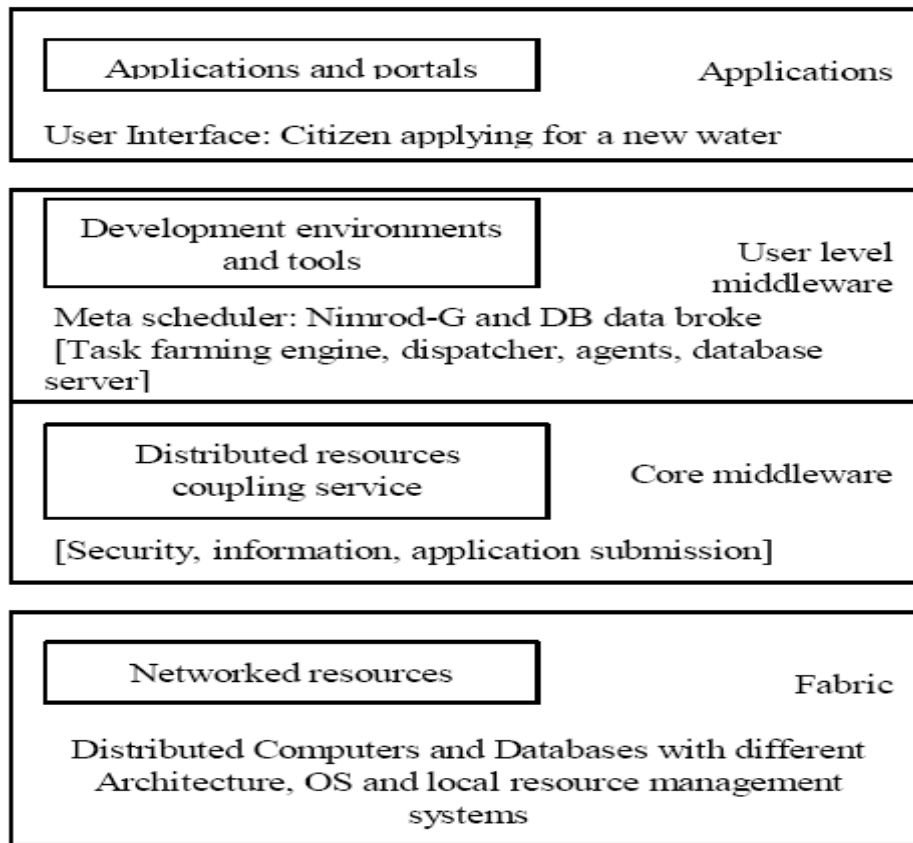

Figure 1: Layered Grid architecture
E-Governance under Grid System

Because e-governance is the use of information and communication technologies to support good governance, the key characteristics of all e-governance projects are that the number of users of the system is enormous. As time progresses, the number of applications also increases in direct proportion. Hence the system has to provide facilities for handling large loads. All e-governance applications must strictly adhere to specifications otherwise it is liable for legal prosecutions. The hardware and software heterogeneity exists in all spheres of e-governance. Hence there is a need for extensive integration. The important anticipated benefits of e-government include improved efficiency, convenience and better accessibility of public services (Sameer, 2002).

The Proposed Framework

The proposed framework is to test how to obtain free health care scheme from municipals health centres. It is assumed that those municipalities has computerized their health care system operations and are web-enabled. The process cycle of obtaining a free health care scheme is as depict below.

The applicant has to submit an e-application for a new free health care scheme. The Corporation server checks whether the Survey Field Number (SF number) of the applicant has been regularized by the concerned authorities. Once the Corporation server identifies that the SF number is a regularized one, the applicant is allowed to have access to the service and passed the information to the Electronic Bill server (EB server). The EB server then verifies whether the beneficiary has paid for utility services from the government and that all necessary charges for the same have been remitted. The server then calculates the beneficiary’s tax and returns the information back to Corporation server. This server finally verifies whether the tax and other related charges have been paid up-to-date.

Once all the above processes are completed, the Corporation server sends the information to the Comprehensive Welfare and Social Services server (CWSS server). This server then approves the free health care system, allots a free health care scheme serial number and then calculates charges to be paid by the government on that particular beneficiary. This is also useful to track the total amount of the annual budget expended on such scheme.

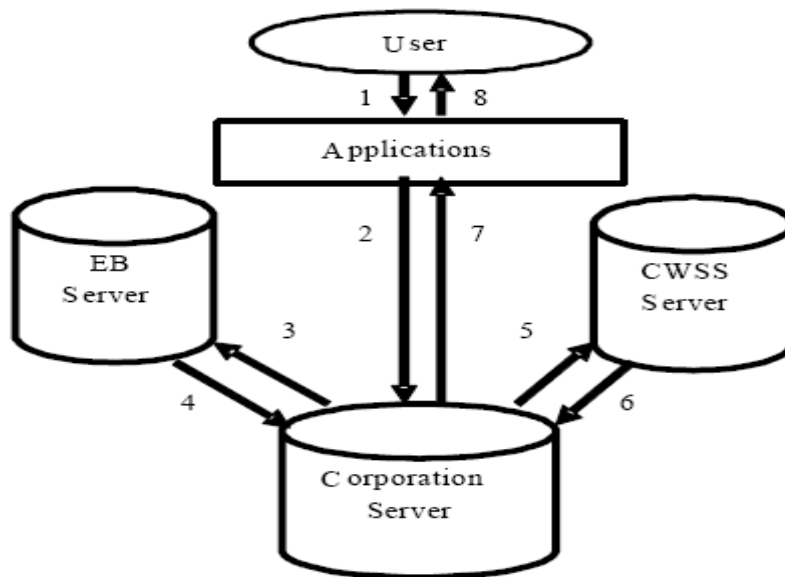

Figure 2: Architectural Design of the proposed e-governance Grid system

Interaction between components of e-governance and grid resource broker

Grid resource broker is designed to operate in an environment that comprises a set of sites, each providing access to a set of Servers. The GridSim toolkit is used to simulate a Grid environment. The simulated Grid environment contains multiple resources and user entities with different requirements. The user and broker entities extend the GridSim class. All the users create application specification requirements and quality of services requirements. When the simulation starts, the user entity creates an instance of its own broker entity and passes a request for processing application jobs.

The GridSim toolkit presents a complete facility for simulation of different classes of various resources, users, applications, resource brokers and schedulers Rajkumar and Murshed (2002), Luis (2005). It has facilities for the modeling and simulation of resources and connectivity with different capabilities, configurations and domains. It supports application composition, information services for resource discovery and interfaces for assigning application tasks to resources and managing their execution.

The GridSim toolkit resource modeling facilities usually used to simulate the world-wide grid resources. The broker can be used for communication with other entities. In GridSim, application jobs are modeled as gridlet objects that contain all the information related to the job and its execution management details such as job length, disk input/output operations, input and output file sizes and the job originator. The broker uses GridSim's job management protocols and services to map a gridlet to a resource and manage it throughout its lifecycle. The broker also maintains full details of application scheduling trace data both at coarse and fine levels, which can be used in performance analysis.

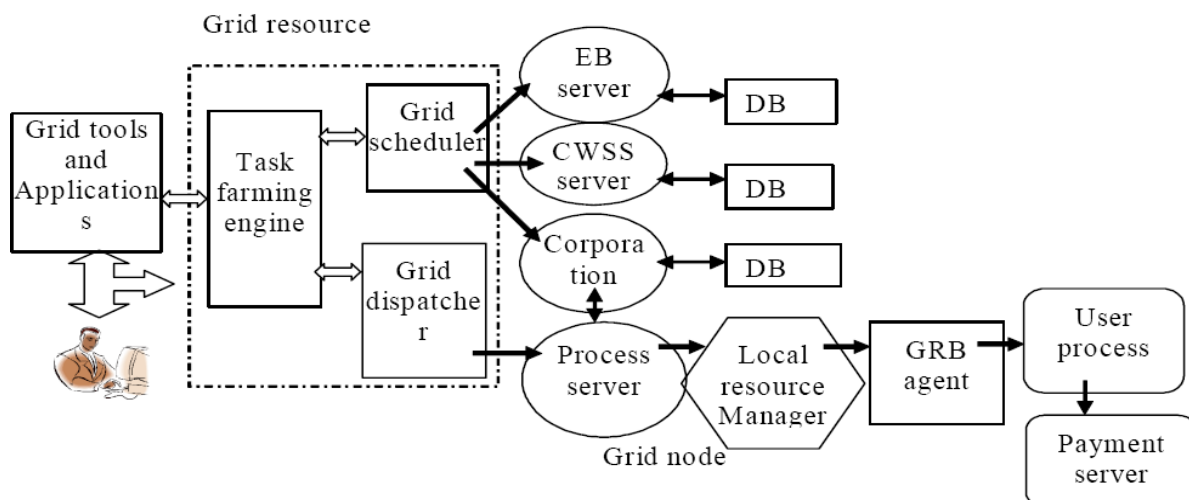

Figure 3: Interactions of Grid Resource Broker and the various components of e-governance applications.

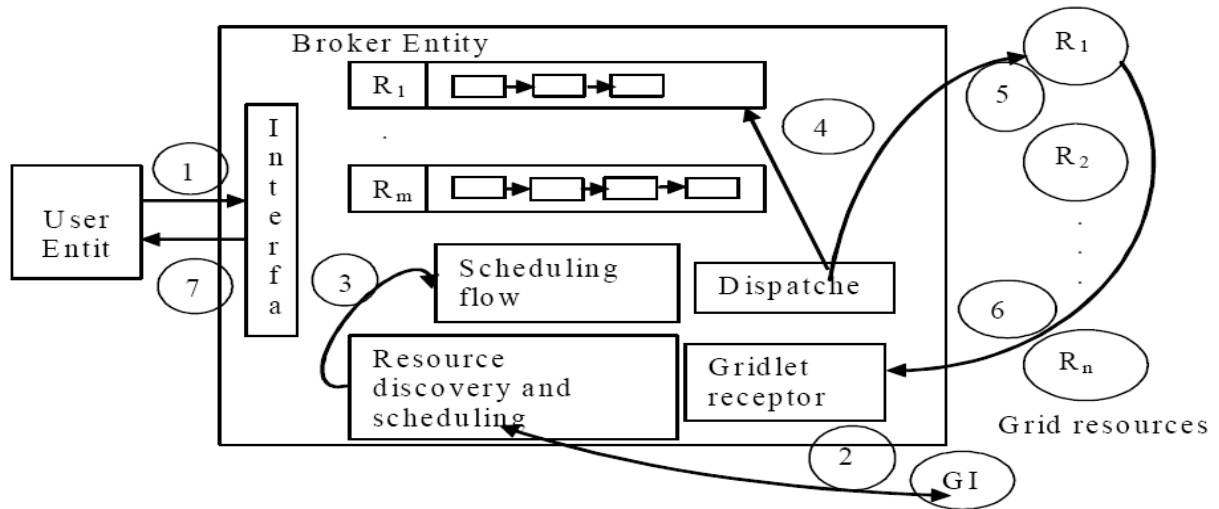

Figure 4: Grid resource broker architecture and its interactions with other entities

Result of the Experiment

The experiments were carried out with two settings using MATLAB. The applications were run with the assumption of being in Grid environment and without being in Grid environment. The comparison of number of jobs completed by each server under the above conditions are shown in Figures 5, 6 and 7 while the comparison of the total time taken for each server to execute all the jobs are shown in Figures 8, 9 and 10.

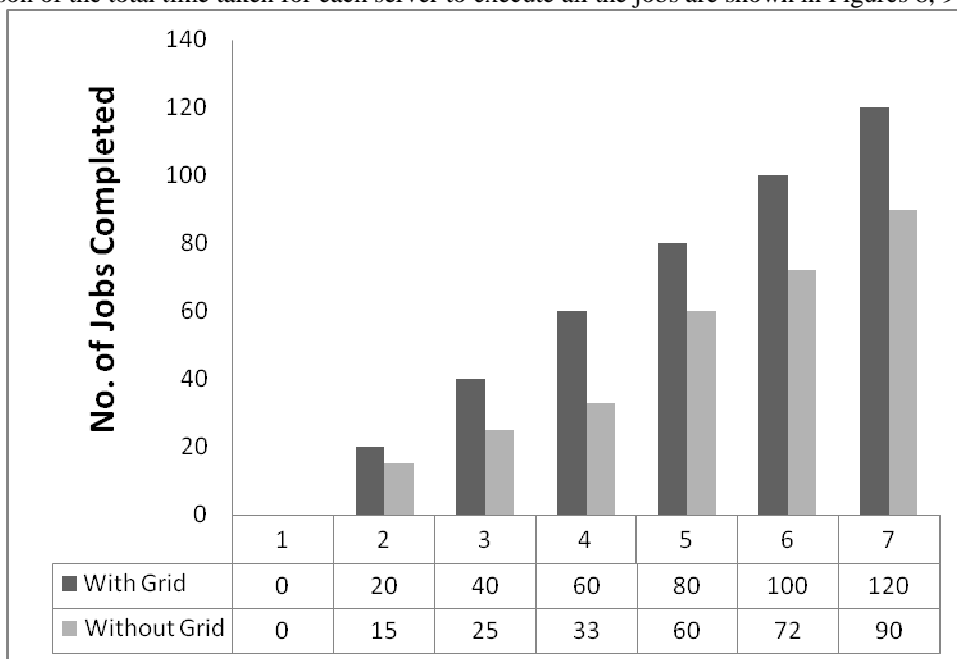

Figure 5: Comparison of number of jobs completed by Electronic Bill server (EB server)

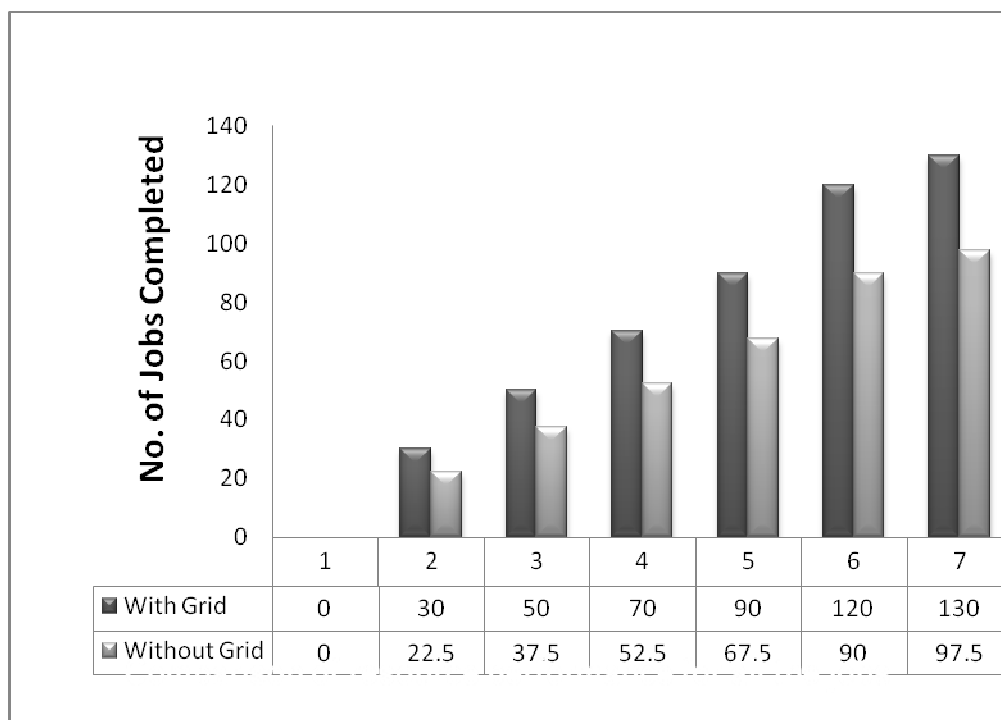

Figure 6: Comparison of number of jobs completed by Comprehensive Welfare and Social Services (CWSS) server

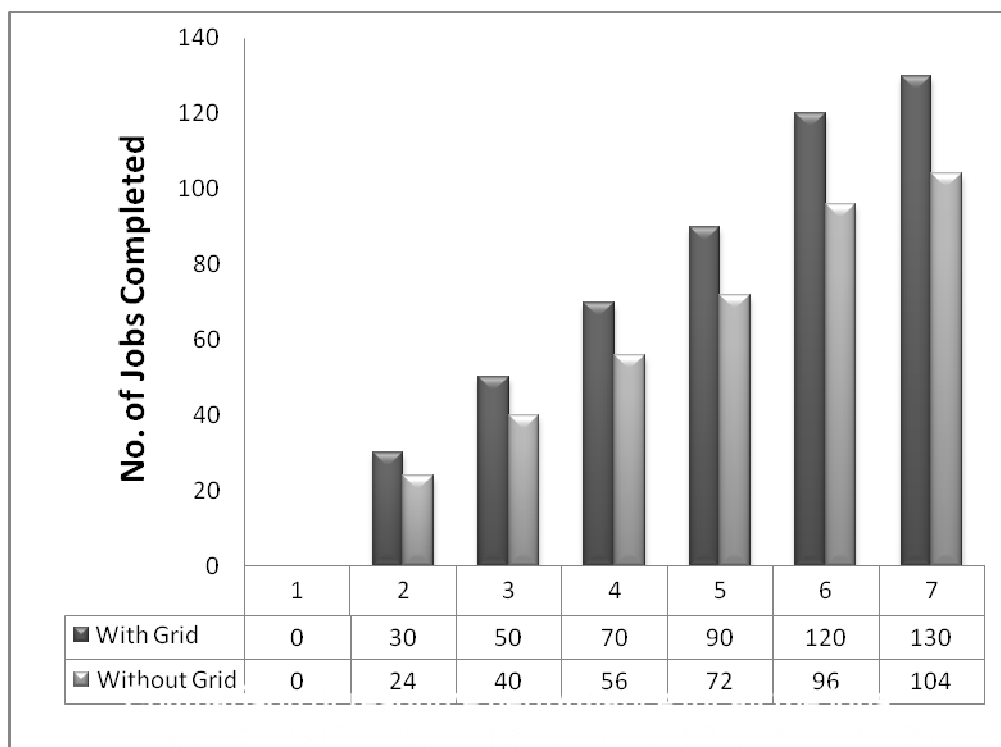

Figure 7: Comparison of number of jobs completed by Corporation server

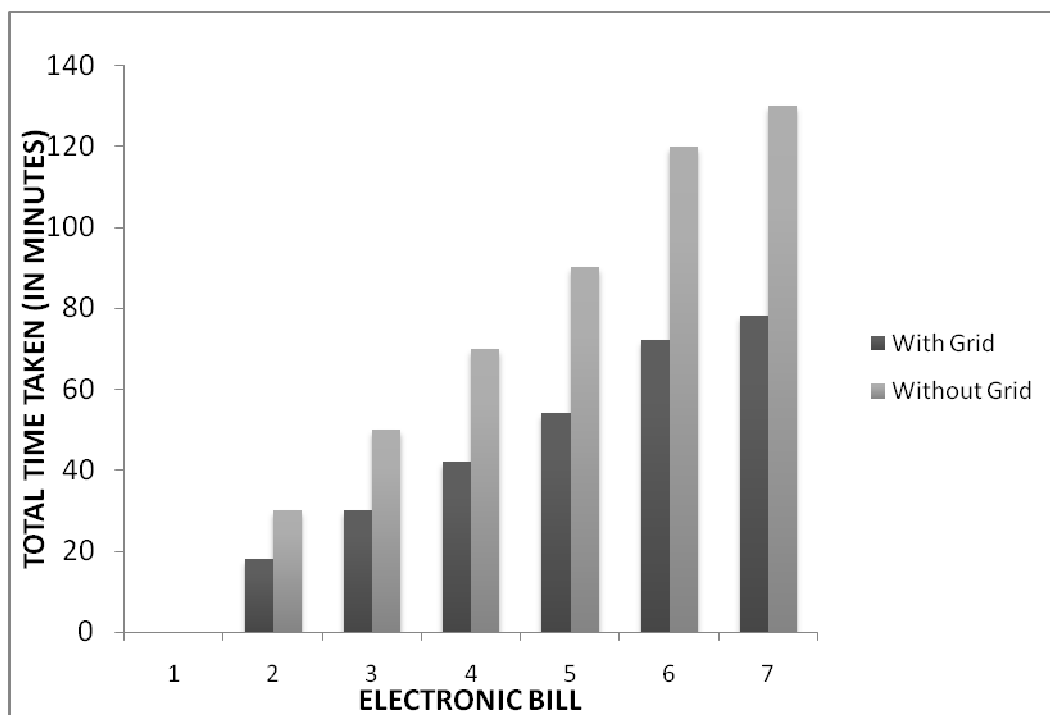

Figure 8: Total Time taken for Electronic Bill Server

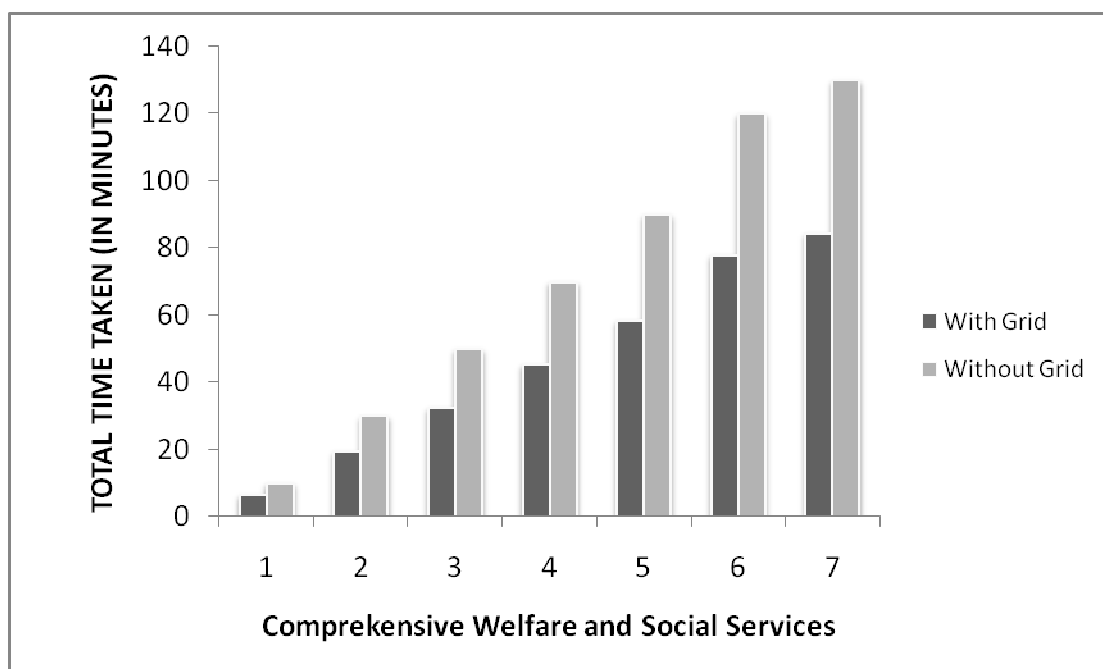

Figure 9: Total Time taken for CWSS Server

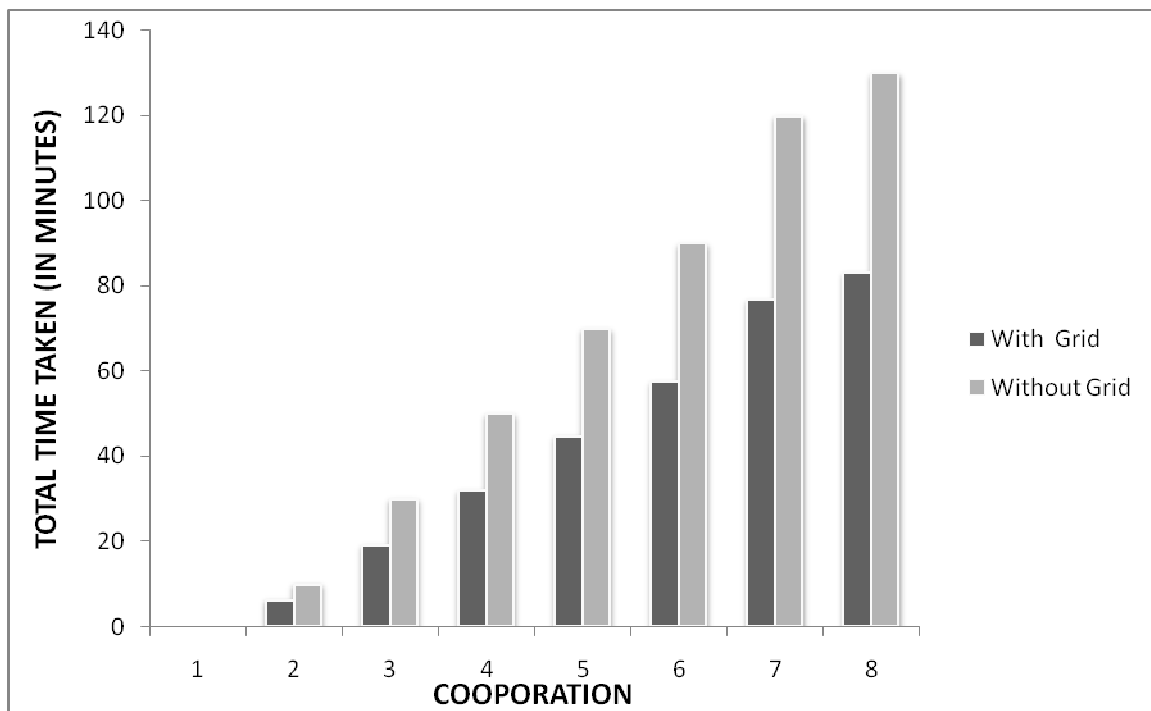

Figure 10: Total Time taken for Corporation

Discussion on result of the experiment

In the first approach, jobs were executed in the EB, CWSS and Corporation servers. As is shown in Figures 5, 6 and 7, all of the servers were executed different jobs. For example the EB server was executed 40 jobs within a given time in the grid environment and only 25 jobs without the grid environment. In same way all the servers were executed more jobs in the grid environment. In the second strategy, jobs were executed in all the servers. For example the CWSS server was executed the given jobs in 78 minutes in the grid environment and took 120 minutes in non-grid environment.

It is obvious from Figures 5, 6, 7, 8, 9 and 10, in the grid environment the application took the least time and completed more jobs than without grid environment. Through the above result presented, we have described how emerging grid computing technologies can be used to implement an e-Governance framework.

Conclusion

This paper has identified and discussed one of the social service areas of e-governance. As a case study, we have presented a scenario of a citizen applying for a new free health care scheme. We have simulated the application within and outside the grid environment. The result shows that rendering service in Grid environment is cost effective with reduced waiting time of the clients which is opposite in non-Grid environment. This is a pointer to the fact that when framework is implemented, it will lead to e-Governance solution with lower cost of developing, deploying, managing government businesses and as well providing better services to citizens. Work is on-going in extending the current framework to implementation level with increased speed in job execution at minimum cost.

Recommendation

It has been observed that in a Grid environment, a set of resources can dynamically team up to solve a given problem. This type of mutual agreement is quite useful for developing computational e-governance applications for the execution of parallel application tasks that have high degree of message communications. Since all the globally distributed resources are accessible from anywhere on the Internet, these resources could be utilized as resource management system as well as special scientific instruments. Due to this dynamic nature of Grid system, there is a need to design and develop an easy to use and secured Grid management infrastructure that will adequately manage the constituent users and resources.

REFERENCES

- Abramson, D., R. Sasic, J. Giddy and B. Hall (1995); Nimrod: A tool for performing parametrised simulations using distributed paperstations. Proceedings of the 4th IEEE International Symposium on High Performance Distributed Computing, Washington, DC, USA., pp: 112-121. DOI: 10.1109/HPDC.1995.518701
- Allen, G. (2000); The cactus code: A problem solving environment for the grid. Proceedings of the 9th International Symposium on High Performance Distributed Computing, IEEE Press, Pittsburgh, PA, USA., pp: 253-260.
- Baru, C., R. Moore, A. Rajasekar and M. Wan (1998); The SDSC storage resource broker. Proceedings of the Conference of the Centre for Advanced Studies on Collaborative Research. IBM Press, Toronto, Ontario, Canada.
- Berman, F., and R. Wolski (1997); The Apples project: A status report. Proceedings of the 8th NEC Research Symposium, Germany. Elsevier Press, Amsterdam.
- Luis F. (2005); Grid Computing in Research and Education, IBM Red Books. ISBN: 0738491756.
- Rajkumar B., D. Abramson and S. Venugopal (2005) ; The Grid Economy, Special Issue on Grid Computing, Proceedings of the IEEE, Manish Parashar and Craig Lee (Eds.). IEEE Press, New York, USA, pp: 698-714.
- Rajkumar B. and M. Murshed (2002); Gridsim: A toolkit for the modeling and simulation of distributed resource management and scheduling for grid computing. Concurrency. Computation Practical Experience, 14: 1175-1220.
- Sameer, S. (2002); E-governance strategy in India, December 2002.

This academic article was published by The International Institute for Science, Technology and Education (IISTE). The IISTE is a pioneer in the Open Access Publishing service based in the U.S. and Europe. The aim of the institute is Accelerating Global Knowledge Sharing.

More information about the publisher can be found in the IISTE's homepage:

<http://www.iiste.org>

CALL FOR JOURNAL PAPERS

The IISTE is currently hosting more than 30 peer-reviewed academic journals and collaborating with academic institutions around the world. There's no deadline for submission. **Prospective authors of IISTE journals can find the submission instruction on the following page:** <http://www.iiste.org/journals/> The IISTE editorial team promises to review and publish all the qualified submissions in a **fast** manner. All the journals articles are available online to the readers all over the world without financial, legal, or technical barriers other than those inseparable from gaining access to the internet itself. Printed version of the journals is also available upon request of readers and authors.

MORE RESOURCES

Book publication information: <http://www.iiste.org/book/>

Recent conferences: <http://www.iiste.org/conference/>

IISTE Knowledge Sharing Partners

EBSCO, Index Copernicus, Ulrich's Periodicals Directory, JournalTOCS, PKP Open Archives Harvester, Bielefeld Academic Search Engine, Elektronische Zeitschriftenbibliothek EZB, Open J-Gate, OCLC WorldCat, Universe Digital Library, NewJour, Google Scholar

