

# **Analytical of Compensation Factor, Job Stress and Motivation Campaign Against Occupation and Work Discipline and Its Effect on Employee Performance**

## **(A Study on the Employees of PT PLN (Persero) Region Suluttenggo)**

Alicia Sumenge

Doctoral Student of Science Management Program  
Faculty of Economics and Business, University of Sam Ratulangi, Manado, Indonesia

### **Abstract**

The aim of this study is to examine and analyze the factors compensation, job stress and the promotion of the motivation and discipline of work and its influence on employee performance. The populations in this study are the employees of PT. PLN (Persero) Region Suluttenggo. Total population is 1,418 employees. Total sample are 279 respondents. It is using proportional stratified random sampling method. This study using path analysis (path analysis) with three sub-structure model is analyzed. The study produced some conclusions, namely (1) Compensation significant positive effect on employee motivation; (2) Work stress significant negative effect on work motivation; (3) Promotions significant positive effect on employee motivation; (4) Compensation significant positive effect on work discipline; (5) Work stress significant negative effect on work discipline; (6) Promotions significant positive effect on work discipline; (7) Motivation significant positive effect on work discipline; (8) Compensation significant positive effect on employee performance; (9) Work stress is a significant positive effect on employee performance; (10) Promotions significant positive effect on employee performance; (11) work motivation significantly positive effect on employee performance; and (12) working Discipline significant positive effect on employee performance.

**Keywords:** Employee Performance, Compensation, Job Stress, Promotion, Work Motivation, Work Discipline.

### **1. Introduction**

Facing increasingly intense global competition, rapid technological developments evolve, demographic changes, the uncertain economic situation and other dynamic changes have triggered changes in environmental conditions initially stable, predictable turns into an environment full of uncertainty, complex and rapidly changing. Organization up and running in the middle - the middle of the surrounding environment and are required to be able to adapt on an ongoing basis in order to compete.

Each company has a desire to improve the performance or achievements of employees in a way that is arranged in the program. Therefore, every company expects employees / excel and able to create conditions conducive so that employees will not experience boredom, boredom and lazy work resulting in performance or work performance is lowered and bad. Realizing the importance of the role of employees in the activities of the company, then the company needs to manage employees as possible, because the key to the success of a company is not only the benefits of technology and the availability of funds, but the human sector. Companies are required to seek the best solution in order to move / managing employees and improve the performance of its employees, in order to consciously and responsibly carry out the task as well as possible.

In fact, in Indonesia and also possibly in other countries, the overall performance of the employee has not reached the maximum level. Employee performance is seen as a concept that is influenced by various factors, labor discipline is one that is regarded as a predictor of the cause rise / drop in employee performance. Why work discipline is important to work on? The employees were disciplined and obey the rules, norms and regulations - norma in the company can improve the efficiency, effectiveness, productivity and performance (Marihot, 2002). This of course will have a positive impact for the company and for the employees themselves.

The next predictor factor is motivation was seen as a factor to the rise / drop in employee performance. Why is employee motivation important? Employees as the actors who supports the achievement of corporate objectives, have thoughts, feelings, and desires that can affect his attitude towards work. Compared with employees who are less motivated, employees who have high motivation will demonstrate achievement (work / performance) and his love for the work assigned to him. Lack of attention to the motivation can result in losses for the company itself.

Furthermore, the compensation factor has an important role to improve performance. Why does the compensation to be one important variable to be investigated? The purpose of employment generally expects financial compensation. Although there are some people who have different opinions as there are also employees who work not only - the eye tends to expect remuneration in the form of financial compensation. But this is not

always true, especially for employees who work with a view to meeting the needs of life and family. Without the fulfillment of these requirements, the employee will not be able to work well and declining performance which resulted in losses for the company. Especially in the economic condition of the State of Indonesia today, rising fuel prices (fuel oil) also have an impact on people's lives all factors in all groups including employees, that everything was gasoline, pay-paced, paced expensive (all BBM).

Then, work stress factor is the next factor that affects employee performance (Cooper, in Rice 2000). Company's target is a workload to be done by employees in the company. Kuan & Bat (1995), Aun and Yahya (1998) proved that excessive workloads effect on job stress. The workload is too excessive to be done will be a source of stress for employees.

The last factor becomes a predictor rise / decline in the performance of employees, namely promotion. Why promotion needs to be investigated? Non-material needs of man one of them is the desire to progress and develop in their work.

## **2. Literature Review**

### **2.1. Employee Performance**

Motowidlo et al. (1997) and Viswesvaran & Ones (2000) (in Jimoh, 2008) states that the performance of employees is the actions, behaviors and outcomes that can be measured in which the employee is bound or committed employees associated with organizational objectives and contribute to organizational goals.

Performance is a universal concept which is the operational effectiveness of an organization, part of the organization, and its employees based on the standards and criteria established sebelumnya. Organisasi basically run by humans, the actual performance is human behavior in that they do play a role in an organization to meet the standards of behavior that has been set in order to produce results and the desired action (Winardi, 1996 in Jimoh, 2008).

The purpose and goal is to develop performance targets are useful, not only for performance evaluation at the end of a particular period, but rather the result of the work process during the period (Simamora, 2006).

### **2.2. Compensation**

Simamora (2006) states that a good compensation is compensation that is responsive to the situation and the system that can motivate employees. Compensation system should satisfy the needs of employees. Ensure fair treatment of them in terms of compensation have been able to create conditions as described above, the employee will be happy to meet demand management to work optimally.

Financial compensation consists of direct and indirect compensation. Direct compensation consists of payment of employees in the form of wages, salaries, bonuses or commissions. Indirect compensation or benefit consists of all payments not covered in direct financial compensation which includes vacation, various kinds of insurance, services, such as child care or religious concerns, and sebagainya. Nonfinancial awards such as praise, respect and self-recognition that can affect employee motivation, productivity and employee satisfaction.

### **2.3. Job Stress**

Luthans (2006), stress is defined as an adaptive response to external situations that produce deviations physical, psychological and or behavior of the members of the organization. All ditunjukkan response to the stressor, either physiological or psychological response, called the stress.

Beehr and Newman in Luthans (2006) defines that work stress as a condition arising from the interaction between people and jobs and characterized by changes in humans that forced them to deviate from their normal function.

### **2.4. Job Promotion**

Hasibuan (2005) says that: Promotion is perpidahan which enlarge the authority and responsibility of employees to higher position within an organization so that the obligations, rights, status and greater penghasilannya.

Andrew F. Sikula (2001, in Hasibuan, 2005) has states that in the way of promotion technique, job promotion is transfer within an organization from one position to another involving the increase of wages and status.

### **2.5. Work Motivation**

Fuad Mas'ud (2004) defines motivation as a driver (driver) is there in a person to act. To be able to carry out tasks and work well requires motivation of each employee. Employees who have a high motivation to be able to perform the job better, compared with employees who lack motivation. Everyone has something that can trigger (move) either in the form of material, emotional, spiritual, and values or certain beliefs.

## **2.6. Work Dicipline**

Sastrohadiwiry (2003) explains that labor discipline is an attitude of respect, respect, obey, and obey the regulations that apply both written and unwritten and able to run and do not swerve to accept sanctions - sanctions if it violates the duties and authority given to him , Good work discipline reflects the person's sense of responsibility towards the tasks given kepadanya. Apabila everyone in the organization can control themselves and comply with all existing regulations, then this could be the key for the company in achieving its goals.

## **3. Research Methodology**

### **3.1. Population and Sample**

The populations in this study are the employees of PT PLN (Persero) Region Suluttenggo in various hierarchy which amounts to 1,418 people. Specified minimum number of samples was 279 employees based table-Michael Isaac with a confidence level of 95%.

The sampling technique used is proportional stratified random sampling technique (Proportional Stratified Random Sampling). This sampling technique is used because the population is not homogeneous (heterogeneous). The scale of the instrument used in this study is a Likert scale (scale 1-5).

### **3.2. Validity and Reliability**

The technique used to perform the validity test is the test of convergent validity. Convergent validity relates to the principle that the gauges of a construct should have a high correlation. Validity test was given to 30 people who were like the respondent. The instrument is declared invalid if it has a value of correlation between the scores grains with a total score of more than 0.30 (Sugiyono, 2011).

A construct or variable is declared reliable if it produces a value of Cronbach Alpha > 0.60 (Sugiyono, 2011). Tests carried out using the IBM-SPSS 22.0 program.

### **3.3. Variable Operational Definition and Measurement**

#### **a. Compensation**

Is everything received by employees of PT. PLN (Persero) Region Suluttenggo as remuneration for their contribution to the company.

#### **b. Work Stress**

Is a consequence of every action and environmental situations that cause psychological and physical demands of excessive employee PT. PLN (Persero) Region Suluttenggo

#### **c. Job Promotion**

A change in the position of employees of PT. PLN (Persero) Region Suluttenggo to a higher level resulting in a higher responsibility, discipline, and income increased and demanding skills and abilities better.

#### **d. Work Motivation**

As the intensity, direction and persistence of employees of PT PLN (Persero) to achieve the goal.

#### **e. Work Dicipline**

As a reflection of the magnitude responsibility of employees of PT. PLN (Persero) Region Suluttenggo to the task given by the company.

#### **f. Employee Performance**

A process of formal discussion between employees with direct supervisor conducted at the end of employee performance management cycle in order to assess the achievements of the achievements obtained by the employees concerned. The operational definition of employee performance in this study, refers to the notion that there is at PT PLN (Persero) Region Suluttenggo.

**Table 1. Research Variable and Indicator**

Variable	Indicator	Source
Compensation (X <sub>1</sub> )	1. Non-financial compensation(X <sub>1.1</sub> ) 2. Financial compensation (X <sub>1.2</sub> )	Handoko (2001)
Job Stress (X <sub>2</sub> )	1. Amount of task (X <sub>2.1</sub> ) 2. Task completion time (X <sub>2.2</sub> ) 3. Role ambiguity (X <sub>2.3</sub> ) 4. Frustrating (X <sub>2.4</sub> )	Davis dan Newstrom dalam Mulyani (2008)
Job Promotion (X <sub>3</sub> )	1. The promotion of job opportunities for employees(X <sub>3.1</sub> ) 2. Provision of promotion on the basis of ability.(X <sub>3.2</sub> ) 3. Wisdom promotion conducted fairly. (X <sub>3.3</sub> ) 4. Clarity base or promotional provisions. (X <sub>3.4</sub> )	Hasibuan (2003)
Work Motivation (X <sub>4</sub> )	1. Achievement needs (X <sub>4.1</sub> ) 2. Authority needs (X <sub>4.2</sub> ) 3. Afiliation needs (X <sub>4.3</sub> )	McClelland (2006)
Work Dicipline (X <sub>5</sub> )	1. Absence / Presence (X <sub>5.1</sub> ) 2. Compliance with the obligations and regulatory duties (X <sub>5.2</sub> ) 3. Working according to the procedure (X <sub>5.3</sub> )	Rivai (2005)
Employee Performance (Y)	1. Work result quality (Y <sub>1</sub> ) 2. Quantity. (Y <sub>2</sub> ) 3. Timeliness Finish Work (Y <sub>3</sub> ) 4. Work Effectiveness (Y <sub>4</sub> ) 5. Work independently. (Y <sub>5</sub> ) 6. Work Commitment. (Y <sub>6</sub> )	As'ad (1995)

### 3.4. Data Analysis Method

Path analysis is a statistical technique to examine the causal relationship between two or more variables. Path Analysis (PA) is the relationship between independent variable. Intermediate variables and the dependent variable are usually presented in the form of a diagram. In the diagram there are arrows indicating the direction of influence between exogenous variables, intermediary, and the dependent variable. (Riduwan and Kuncoro, 2007)

## 4. Result of Analysis

### 4.1. Validity and Reliability Test

The validity test results are shown in the Table 2 below:

**Table 2. Validity Research Instrumen**

Item	r correlation	Information	Item	r correlation	Information
X <sub>1.1.1</sub>	0.751	Valid	X <sub>3.4.1</sub>	0.768	Valid
X <sub>1.1.2</sub>	0.771	Valid	X <sub>3.4.2</sub>	0.795	Valid
X <sub>1.1.3</sub>	0.908	Valid	X <sub>4.1.1</sub>	0.793	Valid
X <sub>1.2.1</sub>	0.823	Valid	X <sub>4.1.2</sub>	0.713	Valid
X <sub>1.2.2</sub>	0.765	Valid	X <sub>4.2.1</sub>	0.701	Valid
X <sub>1.2.3</sub>	0.864	Valid	X <sub>4.2.2</sub>	0.700	Valid
X <sub>2.1.1</sub>	0.881	Valid	X <sub>4.3.1</sub>	0.860	Valid
X <sub>2.1.2</sub>	0.760	Valid	X <sub>4.3.2</sub>	0.746	Valid
X <sub>2.2.1</sub>	0.853	Valid	X <sub>5.1.1</sub>	0.734	Valid
X <sub>2.2.2</sub>	0.764	Valid	X <sub>5.1.2</sub>	0.801	Valid
X <sub>2.3.1</sub>	0.748	Valid	X <sub>5.2.1</sub>	0.802	Valid
X <sub>2.3.2</sub>	0.703	Valid	X <sub>5.2.2</sub>	0.724	Valid
X <sub>2.4.1</sub>	0.853	Valid	X <sub>5.3.1</sub>	0.712	Valid
X <sub>2.4.2</sub>	0.829	Valid	X <sub>5.3.2</sub>	0.849	Valid
X <sub>3.1.1</sub>	0.881	Valid	Y <sub>1</sub>	0.827	Valid
X <sub>3.1.2</sub>	0.664	Valid	Y <sub>2</sub>	0.772	Valid
X <sub>3.2.1</sub>	0.793	Valid	Y <sub>3</sub>	0.855	Valid
X <sub>3.2.2</sub>	0.718	Valid	Y <sub>4</sub>	0.766	Valid
X <sub>3.3.1</sub>	0.779	Valid	Y <sub>5</sub>	0.836	Valid
X <sub>3.3.2</sub>	0.852	Valid	Y <sub>6</sub>	0.876	Valid

Source: Data Analysis Result, 2015.

Reliability test results are shown in Table 3 below:

**Table 3. Reliability Research Instrument**

Variable	Alpha Cronbach	Information
Compensation (X <sub>1</sub> )	0.762	Reliable
Job Stress (X <sub>2</sub> )	0.798	Reliable
Job Promotion (X <sub>3</sub> )	0.732	Reliable
Work Motivation (X <sub>4</sub> )	0.765	Reliable
Work Dicipline (X <sub>5</sub> )	0.768	Reliable
Employee Performance(Y)	0.828	Reliable

Source: Data Analysis Result, 2015.

#### 4.2. Path Analysis Result

Measures undertaken in path analysis in this study are as follows:

**a) Make a path diagram based on the existing relationship between variables in the model**

Research model path diagram shown in Error! Reference source not found. 1 are as follows:

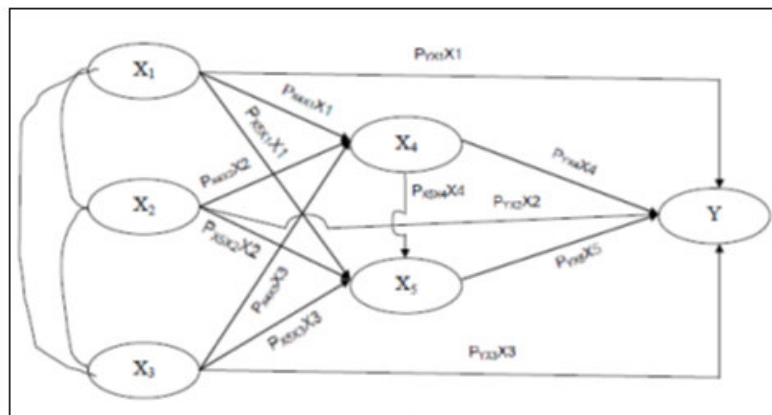

**b) Creating Structural Equation**

Based on the Error! Reference source not found. 1 above then formed three structural equations, which are:

1.  $X_4 = p_{X_4X_1}X_1 + p_{X_4X_2}X_2 + p_{X_4X_3}X_3 + \epsilon_1$  (Sub-Structure 1)
2.  $X_5 = p_{X_5X_1}X_1 + p_{X_5X_2}X_2 + p_{X_5X_3}X_3 + p_{X_5X_4}X_4 + \epsilon_2$  (Sub-Structure 2)
3.  $Y = p_{YX_1}X_1 + p_{YX_2}X_2 + p_{YX_3}X_3 + p_{YX_4}X_4 + p_{YX_5}X_5 + \epsilon_3$  (Sub-Structure 3)

**c) Calculating the path coefficient based on the regression coefficients.**

Basically the path coefficients (path) is a standardized regression coefficients, namely: the regression coefficient is calculated from the data base that has been set in order raw or Z-score (the data set with an average value = 0 and standard deviation = 1). Standardized path coefficient (standardize path coefficient) is used to describe the influence of independent variables (exogenous) against the other variables imposed as the dependent variable (endogenous). Path coefficients addressed by the output coefficient called or known as Beta.

**d) Calculating the path coefficient simultaneously (overall)**

If  $F_{count} \geq F_{table}$ , then reject  $H_0$  and  $H_a$  accepted means to significantly and  $F_{arithmetic} \leq F_{table}$ , thank  $H_0$  and  $H_a$  denied means insignificant.

**e) Calculating the coefficient track individually.**

Individually statistical test used was t test. If the value of  $t_{arithmetic} \geq t_{table}$ , then reject  $H_0$  and  $H_a$  received significant meaning. If the value of  $t_{arithmetic} \leq t_{table}$ , then accept  $H_0$  and  $H_a$  denied means insignificant.

**f) Summarize and Conclude.**

After counting the results obtained in the study make the summary of the results are then analyzed and summarized useful for decision-making research.

#### Empirical Model Sub-Structure1

Based on the analysis result, empirical model sub-structure 1 can be seen in the Figure 2 below:

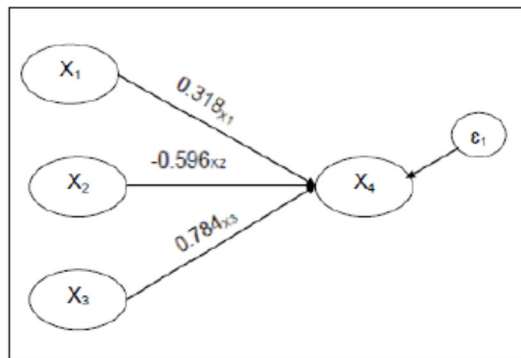

Figure 2. Empirical Model Sub-Structure 1

Summary

Table 4. Analysis Result of Sub – Structure 1

Variable	Path Coefficient (beta)	Effect		Simultaneous effect
		Direct	Total	
X1	0.318	0.318	0.318	-
X2	-0.596	-0.596	-0.596	-
X3	0.784	0.784	0.784	-
X1, X2, X3				0.755

Source :Data Analysis Result, 2015

Empirical Model Sub-Structure 2

Based on the analysis, the empirical model of the sub-structure 2 can be seen in Figure 3 below:

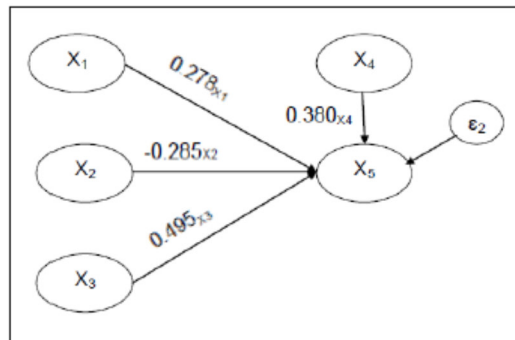

Figure 3. Empirical Model Sub-Structure 2

Summary

Table 5. Analysis Result of Sub-Structure 2

Variable	Path Coefficient (beta)	Effect		Simultaneous effect
		Direct	Total	
X1	0.278	0.278	0.278	-
X2	-0.285	-0.285	-0.285	-
X3	0.495	0.495	0.495	-
X4	0.380	0.380	0.380	-
X1, X2, X3, X4				0.728

Source: Data Analysis Result, 2015

Empirical Model Sub-Structure 3

Based on the analysis result, the empirical model sub-structure 3 can be seen in the Figure 4 below:

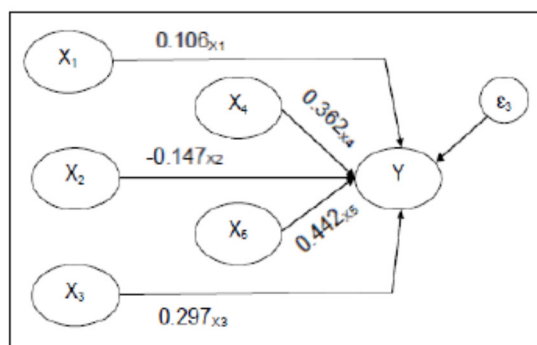

Figure 4. Empirical Model Sub-Structure 3

Summary

Table 6. Analysis Result Sub-Structure 3

Variable	Path Coefficient (beta)	Effect		Simultaneous effect
		Direct	Total	
X1	0.106	0.106	0.106	-
X2	-0.147	-0.147	-0.147	-
X3	0.297	0.297	0.297	-
X4	0.362	0.362	0.362	-
X5	0.442	0.442	0.442	-
X1, X2, X3, X4, X5				0.715

Source : Data Analysis Result

Here is a model of empirical research to a whole sub-structures are formed:

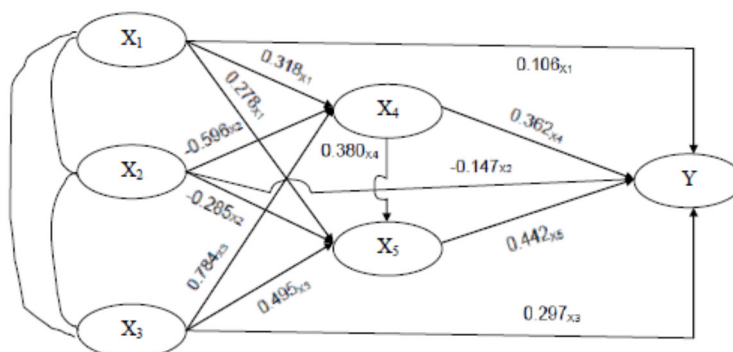

Figure 5. Diagram of Empirical Path Model

5. Discussion

Based on Table 4, R-square values obtained (Effect of Simultaneous) 0755, or 75.5%. This figure has meaning the influence Compensation (X1), Job Stress (X2) and Job Promotion (X3) on work motivation (X4) simultaneously (Combined). While 24.5% are influenced by other factors not included in the model.

For Compensation (X1) has a value of 0318. Work Stress (X2) has a value of -0596. As for the Promotion of Position (X3) has a value of 0784. These figures have the meanings that influence compensation (X1), Job Stress (X2), and Job Promotion (X3) on work motivation (X4) partially respectively by 31.8%, 59.6%, 78.4% and 68.2%. Meanwhile 40.4%, and 21.6% influenced by other factors not included in the model.

Based on Table 5, R-square values obtained (Effect of Simultaneous) 0728, or 72.8%. This figure has meaning the influence Compensation (X1), Job Stress (X2), Promotion of Position (X3), and work motivation (X4) against Work Discipline (X5) simultaneously (Combined). While 27.2% are influenced by other factors not included in the model.

For Compensation (X1) has a value of 0.278. Work Stress (X2) has a value of -0285. As for the Promotion of Position (X3) has a value of 0.495. Those figures have meanings that influence compensation (X1), Job Stress (X2), Promotion of Position (X3) and work motivation (X4) against Work Discipline (X5) respectively partially by 27.8%, 28.5%, 49, 5% and 38%. While 72.2%, 71.5%, 50.5% and 62% influenced by other factors not included

in the model.

Based on Table 6, R-square values obtained (Effect of Simultaneous) 0.715, or 71.5%. This figure has meaning the influence Compensation (X1), Job Stress (X2), Promotion of Position (X3), work motivation (X4) and Work Discipline (X5) on Employee Performance (Y) simultaneously (Combined). While 28.5% are influenced by other factors not included in the model.

For Compensation (X1) has a value of 0.106. Work Stress (X2) has a value of -0.147. Job Promotion (X3) has a value of 0.297. Work motivation (X4) has a value of 0.362. As for Discipline Work (X5) has a value of 0.442. Those figures have meanings that influence compensation (X1), Job Stress (X2), Promotion of Position (X3), work motivation (X4) and Work Discipline (X5) respectively partially by 10.6%, 14.7%, 29.7%, 36.2% and 44.2%. While 89.4%, 85.3%, 70.3%, 63.8% and 55.8% influenced by other factors not included in the model.

## 6. Conclusion

Implementation of compensation in PT PLN (Persero) Region Suluttenggo based on the average percentage of respondents, have a strong category. That is generally compensated perceived by respondents has done well by leaders in the PT PLN (Persero) Region Suluttenggo.

The handling and the stress management of PT PLN (Persero) Region Suluttenggo based on the average percentage of respondents have a strong category. That is the general management of work stress in PT PLN (Persero) Region Suluttenggo related to workload, time of completion of tasks, role ambiguity and workfrustrating well perceived by the respondents.

Implementation of promotions perceived strong by respondents. This means that in general the respondents perceive that the company has been carrying out a promotion program fairly, by looking at the ability of employees through performance evaluation and not choosing - choosing employees who are considered to be close to or have family ties to be promoted to a higher hierarchy.

Implementation of work motivations perceived strong by respondents. This means that in general the respondents perceive that the needs of employees regarding achievement, power, and affiliation contained in the motivation to work has been carried out properly in PT PLN (Persero) Region Suluttenggo.

Implementation of labor disciplines perceived strong by respondents. This means that in general the respondents perceive that the work they have applied the discipline of good work at PT PLN (Persero) Region Suluttenggo.

Implementation of employee performances perceived strong by the respondents. This means that in general employees at PT PLN (Persero) Region Suluttenggo performed very well.

## References

- Aun & Yahya, 1998, the Environmental Effects of Work and Work Stress on Work Motivation and Employee Performance PT. Wijaya International Tribwana.
- Hasibuan H. Malay SP, 2010. Organization and Motivation. Jakarta: PT. Earth Literacy.
- Jimoh, 2008. "Organizational Theory and Behavior". UIN Malang Press.
- Kuan & Bat. 1995. Effect of Work Environment, Work Stress and Conflict on Employee Performance in PT. Bank Sri Partha Headquarters Denpasar, Thesis Master of Management University of Udayana.
- Luthans, Fred, 2006. Organizational Behavior. Yogyakarta: Andi
- Marihot. 2002. Effect of Job Stress, Work Discipline Against Workloads (Studies in Medical Representative in the Holy City). Journal of Psychology, Vol 1, No 1, December. 15-23.
- Mas'ud, Fuad, 2004, Organizational Diagnosis Survey Concepts and Applications, Moulds fourth, Diponegoro University Publishers Agency, Semarang. Sugiyono, 2003. Business Research Methods. Bandung: CV. Alfabeta.
- Rice, Eko. 2000. "Managing Work Stress". Economic focus vol.3, no.2, August.
- Riduwan; Kuncoro Engkos Achmad. 2007. How to Use and Interpret the Path Analysis (Path Analysis). First mold. Bandung: Alfabeta.
- Sastrohadiwiryo, Siswanto, Dr. 2003. Management of Indonesian Workers Administrative and Operational Approach. Jakarta: PT. Earth Literacy.
- Simamora, Henry, in 2006, Human Resource Management, STIE YKPN, Third Edition, Yogyakarta.