

Social Satisfiers and Sustainability of CSR Initiatives: Sri Lankan Perspectives

Ajith Medis*, Assoc. Prof. Dr. David Yong, Prof. Dr. Ali Khatibi, Dr. S.M. Ferdous Azam

Management & Science University

* E-mail of the corresponding author: medisajith@gmail.com

University Drive, Section 13, 40100 Shah Alam, Selangor, Malaysia

Abstract

This paper aims to determine whether the social satisfiers such as entity and community satisfactions lead to sustainability of corporate social responsibility projects; especially within an environment where economic wounds are still being healed and new opportunities are evolving within a society that has endured civil unrest for over 30 years. Government and society at large in a developing country expect corporate businesses to engage in CSR initiatives and complete those projects successfully, in other wards projects to be sustainable. The study used primary collected data for analysis collected from a sample of 360 shareholders /directors /managers /employees of 40 companies and 360 direct/indirect beneficiaries of 40 initiated CSR projects in Sri Lanka; these projects had been completed within a period of 5 years following a long civil war. The researcher used frequency percentage to summarise, descriptive data analysis, structural equation methods to test hypotheses and in-depth interviews. Interestingly, it was found that implementing CSR initiatives focused on merely benefiting society does not guarantee (less significant) sustainability of those initiatives.

Keywords: Social endeavor, CSR, sustainability, biological environment, entity satisfaction, community satisfaction, social environment, core competencies and satisfaction.

1. Introduction

During the last few decades much has been written on corporate responsibilities, corporate social responsibilities, stakeholder analysis, business strategy and competitive advantage (R Edward Freeman, 1984; Kulik, 1999; I. Maignan, Ferrell & Hult, 1999; Porter, 1990, Dennis & Buchholtz, 2009, Liket & Mass, 2016). Corporate enterprises, governments and the general public have started to regard an importance of CSR as a meaningful concept. People have also started to believe that the company has an obligation to use its resources in ways that benefit society; through its committed participation as a member of society; taking account of society at large and improving welfare within society at large, independent of direct gains of the company (Barnett, 2016, Kok, Van Der Wiele, McKenna, & Brown, 2001); these are all important factors today.

During the last few decades CSR has been regarded as a debatable subject by many scholars and practitioners; many are confused by the role it can play and evidence shows that the level of philanthropic contributions made by companies has grown significantly over the last 20 years(A. B. Carroll, 1999, Liket et al,2015). Many scholars continue to discuss the role and nature of social responsibility of a company within society; in other words, the real purpose of a company's very existence. Is it merely to generate a return (profits), or along with profit are there any other responsibilities that a company has towards its stakeholders. Against this backdrop it is importance to confirm how serious are the satisfaction of various entities affect the sustainability of CSR projects.

2. Corporate Social Responsibility and its paradigm shift

It is a very common difficulty within social sciences to derive one single definition for a subject; CSR is no exceptional. Corporate Social Responsibility can be understood as the voluntary integration of social and environmental concerns into business operations and interaction with stakeholders (Enquist, Johnson, & Skålén,

2006). Latest analyses by Secchi (2007) and Lee (2008) reported that the definition of CSR has been changing in meaning and practice.

The World Business Council for Sustainability Development (2000) define CSR as; the continuing commitment by business to behave ethically and contribute to economic development, whilst improving the quality of life of the workforce and their families, as well as of the local community and society at large. Carroll A.B. (1979) and Andrews (1987) defined CSR as categories of economic, legal, ethical and discretionary activities of a business entity adopted towards the values and expectations of society. Values, ethics and corporate social responsibility are not mutually exclusive; rather they are inter-related and somewhat independent; globally business ethics and values have been around for a very long time. As firms have taken an increasingly strategic view of CSR those without the power to directly affect firms—that is, most of those suffering the worst of society's ills—have become less likely to find a place on corporate agendas (Barnett, 2016). For problems that cross borders and so are difficult or intractable for sovereign governments to address, corporations may be the only viable means of ameliorating causes of great human misery (Scherer, Palazzo, & Matten, 2014).

3. CSR: Social Endeavour

Corporate philanthropy started from the donation of cash/goods to individuals and charities following good days resulting from organisations believing it to be the right thing to do. Business practices based on ethical and moral principles were advocated by pre-Buddhist and pre-Christian thinkers in the early centuries of civilisation e.g. Cicero in the first century and Kautilya in the fourth century BC. According to Weeden (1998), over time, organisations started focusing on the donation of cash and goods to an identified direction or to a particular theme that has some relationship to the company's core business; this practice is called strategic philanthropy. Therefore, it is appropriate to re-look at the way how satisfying various entities have an impact on the sustainability of CSR initiatives.

4. Importance of CSR in Developing Countries.

Despite the concept of CSR as a management tool being new in developing countries, the practice of charitable work has been undertaken for many years. Continental European, Asian and African societies may not use the term CSR in their vocabularies; however, some of these societies have had a long lasting social contract where business has had a social obligation to its' employees and/or the wider society, such as exists in Japan (Turner, 1993).

Rathnasiri, (2003) suggests in his research that amongst fifty local companies in Sri Lanka, there was no consensus within the private sector as to what CSR is. Kariyapperuma, (2011) interestingly found in his research that CSR involvement within Sri Lankan insurance companies suggests that the majority of the companies considered CSR as either a pure philanthropic act or to be used totally as a marketing tool. He also states that many of the CSR activities of the insurance companies are not strategically aligned to their core business or the operation of the organisation.

Blowfield (2005) questions whether CSR can help companies redefine the meaning of good business practice in the interest of the poor and marginalized; also asking whether CSR helps development practitioners manage the possibilities and consequences of bloat capitalism within poor countries more effectively.

Interestingly in November 2004, following a number of developments within the developing world many socially driven organizations joined together to lobby the need for a meaningful CSR initiative that established a new meaningful agenda for developing countries as its main demand.

As shown in table below it is evident that most (almost 60%) of top Sri Lankan corporations practiced CSR as a charitable initiative instead of a meaningful activity. A critical agenda is necessary for the developing countries because so many authorities, including policy-makers, have identified that corporations can contribute at a higher level in meeting development challenges in many other areas, rather than just purely their economic contribution e.g. eradicating HIV/AIDS, reducing poverty, improving capacity building.

5. CSR and Sri Lankan Corporations

Against this background, the pilot survey was conducted in order to identify how many Colombo Stock Exchange listed companies practice CSR; it also tried to analyse the level of corporate investment in CSR in terms of social-harmony strategy.

The sample was derived from the population of LMD 50 (most respected business entities) and ten of the winning companies from the Ceylon Chamber of Commerce Sustainability awards list. Out of 27 companies 52% of them are engaged in CSR activities; whilst 47% of the sample is involved in some kind of minor charitable activities.

Out of the companies who are involved in CSR activities, 79% of the respondents are engaged in CSR as a social course. In total 89% of organizations practice CSR as a social harmony purpose or a charitable purpose.

6. Background to the Problem

It is of paramount importance that any social or business strategy aligning with CSR should be sustainable in order to gain substantial benefits to both society and to the organizations. This study identifies a number of serious issues for a country such as Sri Lanka will face, due to either a lack of knowledge or ignorance, especially if companies do not focus their CSR initiatives on social endeavor, targeting community satisfaction and entity satisfaction. Table below indicates this very clearly by identifying that not even 1/3 of CSR initiatives were sustainable after 2 years following implementation. The question arises; satisfying both entity and community will lead to the sustainability of CSR projects. Thus, the following research question is addressed based on the research problem stated above as: what are the factors associated with CSR as a social satisfiers and significance of those to the sustainability of CSR initiatives.

7. Significance of the Study

Sri Lanka, a developing island nation, has gone through many ups and downs in the past and the country is just recovering from a 30-year long war. Although the war only restricted to North and Eastern parts of the country, it had a substantial impact on the economy, culture, and physical well being of the people of Sri Lanka; the country is still suffering from these past horrifying events and still has an impact on many lives.

The Central Bank of Sri Lanka in its reports continuously says, “the private sector is the engine of growth” in this highly economic disparity society. Companies that weren’t able to make a sound return for their shareholders have started to earn souring profits after the war. Today large numbers of the top listed companies are disclosing over a billion Rupee profit and it has become a competition to make more billions in order to gain greater investor confidence. The pressure is mounting on CEO’s to attract and keep investors to ensure their own survival. We have seen globally as well as locally that most of the companies are eagerly participating in various social events/competitions to demonstrate that they are good corporate citizens. It has indeed become a must for listed companies to engage in CSR initiatives under the triple bottom line reporting requirements of a good corporate citizen.

Within this environment, we have seen a large number of companies contribute to the well-being of society in different ways; however, the question arises regarding what effect the genuine results have on the very real needs of society and whether these are truly sustainable.

Since Sri Lanka is a developing country it is of paramount importance that CSR initiatives are sustainable. Following the pilot survey and the facts already mentioned, there is a clear indication that company’s lacks clear focus when initiating various sustainable CSR projects. Very few companies have initiated projects, which have given immense benefits to society, or/and to their organisation. The amount of research completed in this area is also limited in Sri Lanka, largely as a result of low academic interest due to the novelty of the concept. Organisations are also confused and lack knowledge as to where they should invest funds in a meaningful manner. Furthermore, after the war, many non-governmental organisations (NGO) in the country are focusing on development work, partnering with many organisations in order to rebuild the country; however, they too lack clear focus on sustainable projects.

8. Literature Review

Corporate Social Responsibility (CSR) is hardly a new concept. According to Waters (2014) it now comes at an awkward moment for corporations, as they need to respond to the requirements of stakeholders as well as to their investors. The basic belief that organizations are accountable to society at large and have developed over the years to companies responding to the society they generate their incomes from.

8.1. The Evolution of CSR

It is interesting to discover the reasons why a corporation is socially responsible whilst making a profit, as opposed to purely making a profit. Questions like, why do corporations need to be socially responsible and what if they are not responsible socially when running their businesses? Academics and practitioners have been searching for answers, using various arguments for years and years.

If we go back in history, although the word CSR was created in the recent past, the practice of the very basic principles can be found in ancient civilization, which goes as far back as the inception of trade and commerce. In the era of Babylon (1760), King Hammurabi, created a code that protected the slaves by forbidding the separation of slaves from their families. Also during the King Louis XIV of France reign, an ordinance was created that introduced measures to preserve the French forests (Esposito, 2009).

Some suggest that social responsibility refers to businesses' decisions and actions taken for reasons, at least partially, beyond the company's direct economic or technical interest. Since late 1950, academics and practitioners have argued that corporations are socially responsible to society in different ways and one research after another has been completed to prove this point. Eells & Walton (1961) argued that CSR refers to the "problems that arise when corporate enterprise cast its shadow on the social scene and the ethical principles that ought to govern the relationship between the corporations and society."

8.2. The Definition of CSR

Although the word CSR is a recent popular term, a pre association of business ethics and the social dimensions of business activity have been in existence for a very long time. Western and eastern thinkers such as Cicero in the first century BC and Kautilya advocated doing business with some moral principles in the fourth century BC respectively. Esposito (2009) shows that the first to introduce and define the term CSR was a Christian Pastor named Rev. Bowen in 1953. Bowen explains that the duty of a businessman is to create policies, take decisions and follow lines of action that are socially desirable and are in line with social values and objectives. He also emphasised that firms need to be cognisant of business ethics to achieve long-term superior performance. Throughout the past 60 plus years' different authors have used different concepts to describe and define CSR e.g. corporate social performance, corporate social responsiveness, corporate citizenship, corporate accountability, corporate sustainability, corporate governance and corporate social entrepreneurship. Latest analyses by Secchi (2007) and Lee (2008) reported that the definition of CSR has been changing in meaning and practice.

According to Maignan & Ferrell, (2004), the different viewpoints of CSR can be categorised into four: CSR as a social obligation; CSR as a stakeholder obligation; ethics driven CSR and CSR as a managerial process.

Further, during the last few decades some CSR activities protected companies when negative publicity emerged (P C Godfrey, Merrill, & Hansen, 2009); some have supported not just the growth of sales but employment/investment too (Sankar Sen, Bhattacharya, & Korschun, 2006) and some with higher CSR ratings have attracted more human capital (Carmeli, 2005).

"The term [social responsibility] is a brilliant one; it means something, but not always the same thing, to everybody. To some it conveys the idea of legal responsibility or liability; to others, it means socially responsible behaviour in an ethical sense; to still others, the meaning transmitted is that of "responsible for," in a causal mode; many simply equate it with a charitable contribution; some take it to mean socially conscious; many of those who embrace it most fervently see it as a mere synonym for "legitimacy;" in the context of "belonging" or being proper or valid; a few see it as a sort of fiduciary duty, imposing higher standards of behaviour on businessmen than on citizens at large (Masaka, 2008).

8.3. Selection of CSR as a Social Endeavour and its Antecedents

Carroll (1991) suggests many points on how a company can be ethically and philanthropically responsible to society: performing up to the expectations of society, its morals and ethical norms; preventing ethical norms being compromised, purely in order to reach corporate goals; the importance of defining what is good corporate citizenship; the importance of adhering to the philanthropic and charitable expectations of society; the importance of employees to attend community activities; the importance of supporting educational institutions and emphasising the implementation of projects that will enhance the "quality of life". These attributes clearly define the need for corporations to adhere and to use CSR for the benefit of social and biological environments, which will eventually lead to the satisfaction in both the community, as well as other entities such as; legal, public, etc. Bartelson (2006) and (Asongu, 2007) explained the strong link between CSR and civil society entities for improved projects. Labib Eid & Robert Sabella, (2014) found strong links between business entities and non-profit organisations in implementing CSR initiatives. The social harmony approach takes a communitarian oriented perspective (Selznick, 1994), it argues that the demand of all stakeholders must be balanced and does not separate ethics from business (Freeman, 1994).

9. Definition of Variables

As the main construct of the conceptual framework is psychological phenomena, there is no one universally accepted definition for each construct. The author, based on the various perspectives that have been presented in previous literature regarding these constructs, developed all operational definitions. Therefore, the research design is based on the operational definitions demonstrated in Table below.

Operational definitions of main variables

Concept	Definition
Community Satisfaction	The extent to which the general community is happy to continuously appreciate an organisation.
Entity Satisfaction	The extent to which the Legal and other government bodies are happy to continuously associate an organization.
Sustainable CSR initiatives	Ability of a company to execute a chosen CSR project for a longer period of time, until the defined objectives being met.

10. Data Collection Target Population and Sampling Frame

A structured, self-administered questionnaire and in-depth interviews were used for the data collection purpose. According to Bryman (2006) designing an appropriate sampling frame is an important step of both qualitative and quantitative research projects. The population in this study are listed companies operating in the Colombo Stock Exchange in Sri Lanka that are practicing CSR and the non-listed companies who have won international awards for CSR initiatives during the last 3 years. The reason for choosing the listed companies to be part of the population is that according to the triple bottom line reporting system it is mandatory for listed companies to report CSR under the sustainability section. Due to the time and cost constraints of using the whole population in the study, it is always advisable to use a sample to achieve the objectives of the study (Barreiro and Albandoz, 2001). The sample size of this study is 800 respondents from 40 companies in Sri Lanka. However, due to issues relating to incomplete information and other difficulties of meeting the respondents, the sample size was limited to 720.

11. Data Analysis and Interpretations

11.1. Testing Normality, Linearity, Homoscedasticity and Multicollinarity

According to Sekaran & Bougie, (2010) normality is the most fundamental analysis of multivariate analysis; this is due to normality being required to complete the F and T statistics (Sekaran, 2006). According to Hair et al., (2010) linearity of the data set is fundamentally very important. Also it is better to note that non-linear effects can downplay the strength of the relationship (Tabachnick & Fidell, 2007).

Test of Normality

Variable	Skewness		Kurtosis		Test Normality		Transformation	Sig. after remedies
	Statistics	Z Value	Statistics	Z Value	Statistics	Sign		
Community Satisfaction	-.085	-0.80	.065	0.410	.086	.065		
Entity Satisfaction	.258	2.454392	.721	.265881	.069	.000	Logarithm	0.13
Sustainable CSR Initiatives	-.696	-6.712	.530	0.345	.087	.051		

Source: Survey Data 2014-2015

Testing for homoscedasticity- Frontier Analysis

Metric Variable	Non Metric Variables											
Variable	Relationship Status		Involving Period		Type of CSR Program		Awareness Level		Customer-Associating		Benefitted CSR	
	Levene Stat	Si	Levene Stat	Si	Levene Stat	Si	Levene Stat	Si	Levene Stat	Si	Levene Stat	Si
Community Satisfaction	8.689	.000	11.115	.065	2.681	.000	3.946	.068	2.450	.877	.677	.114
Entity Satisfaction	1.305	.095	1.456	.502	1.050	.710	.174	.614	2.573	.654	.789	.441
Sustainable CSR Initiatives	2.451	.173	3.876	.432	.131	.076	1.304	.089	6.738	.000	1.349	.663

Source: Survey Data 2014-2015

Multicollinearity

Variable	Shared Correlation (SMC)	Multiple Tolerance Statistics (TS)	Variance Inflation Factor (VIF)
Community Satisfaction		.243	1.256
Entity Satisfaction		.701	2.876
Sustainable CSR Initiatives		.694	3.212

Source: Survey Data 2014-2015

11.2. Descriptive Statistics

Descriptive statistics have been applied to understand the perceived responses to each of the dimensions and it is then followed by the application of inferential statistics.

Summary of descriptive statistics

Dimension	N	Mean	Std. Deviation
Community satisfaction	360	3.4867	.76689
Entity satisfaction	360	3.8188	.55602
Sustainability	360	3.8167	.90762
Valid N (listwise)	360		

Source: Survey Data 2014-2015

The study assessed the beneficiaries view-point regarding CSR activities adopted by the Sri Lankan companies. The beneficiaries believe that CSR programs initiated by their respected organisations are satisfactorily working with local government, small community groups, non-governmental bodies and religious leaders (Entity Satisfaction M=3.8188, SD=.55602). They believe these organisations give more prominence to the CSR

initiatives of company's due to the organised manner of these entities, which is obvious in any society. It is easy for a company to work with organised bodies and implement programs successfully, rather than working with individuals. In addition, the questionnaire was designed to assess the continuity of the CSR activities ($M=3.8167$, $SD=.90762$) implemented by the company's. This shows that there is a tendency among the company's representatives to continue with CSR activities, even though it has considerable dispersion on the idea.

12. Exploratory Factor Analysis (EFA)

12.1. EFA of Social Satisfiers

Social satisfiers have been measured with the help of two dimensions, namely, community satisfaction and entity satisfaction. Further, the concept was measured with a total of 9 items representing five items for community satisfaction and 4 items for entity satisfaction. The Correlation matrix was observed in order to check the factorability of the items and it revealed sufficient correlation among the items to run the PCA.

Sample adequacy was tested with the help of KMO and it exceed the cut of criteria suggested by Kaiser (1974), revealing 788. Bartlett's test of Sphericity was significant (Chi-Squared value=467.215 df=36 and sig=0.00), indicating a correlation matrix and not an identity matrix. Hence, all the data was suitable for factor analysis (PCA). In order to obtain the components a scree plot was observed and it revealed the two components. This was supported by the results revealing two components with eigenvalues > 1 (Kaiser, 1974), explaining 39.151% and 22.331% of the variance, respectively. Orthogonal Varimax rotation was performed and items loaded on components greater than 0.40 were retained, whilst suppressing other items. Table below gives the summary table pertaining to PCA.

Summary of EFA of the Social Satisfiers

Factors	Factor Loading	Eigenvalues	Variance Explained	Cronbach's Alpha	Communality
Community Satisfaction (5 items)		3.524	39.151	.739	
CS1	.556				.311
CS2	.849				.770
CS3	.871				.777
CS4	.820				.675
CS5	.887				.786
Entity Satisfaction (4 items)		2.010	22.331	.704	
ES1	.880				.796
ES2	.688				.485
ES3	.479				.273
ES4	.807				.661

Source: Survey Data 2014-2015

12.2. CFA for Social Satisfiers

According to the structural model, main items were used in the CFA of Social Satisfiers antecedents and the results are given in below table.

Social Satisfier model fit

Model	CFI	GFI	AGFI	IFI	NFI	TLI	RMSEA	CMIN/DF
Before Modification	1.000	0.949	0.903	1.000	0.940	0.930	0.097	4.397
Tolerance Levels	>0.900	>0.900	>0.900	>0.900	>0.900	>0.900	<0.05	1.0<CMIN/DF <5.0

Source: Survey Data 2014-2015

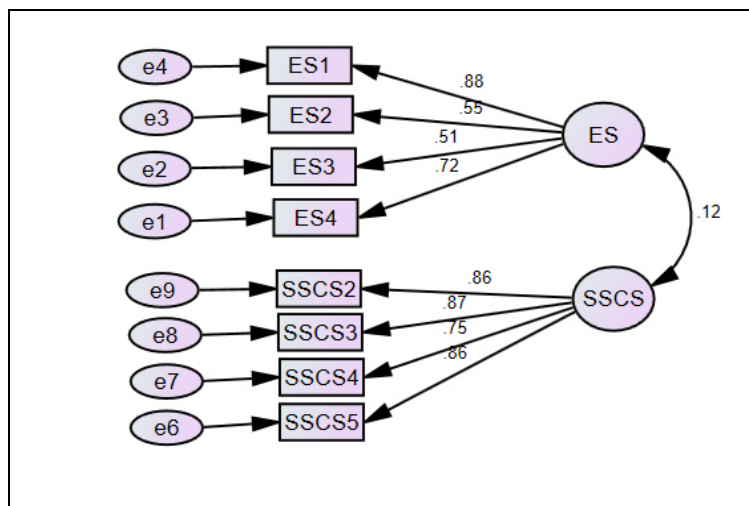

Path diagram of CFA for Social Satisfier

Source: Survey data, 2014 -2015

12.3. Social Satisfier to Sustainability Initiatives

Test Values

	Estimate	S.E.	C.R.	P
ZAvg_SocSat ---> SUS	0.119	0.053	2.244	0.025

Survey Data 2014-2015

Through the model, it was tested to find out the relationship of social satisfiers to sustainability of CSR initiatives and according to the results, it is shown clearly that although the hypothesis is supported by data the level of significance is lower.

The AGM of CSR attached to a garment manufacturing organisation explained during an

In-depth interview in support of the program that;

“Our main CSR initiative has been running for the last 7 years and it has delivered very positive results for both the company and our employees who are the direct beneficiaries of the program. However, the one we recently started for schools, as a social cause, did not last for even two years. What we found was the commitment from our managers was low in terms of the extra time they spent on the program”.

AGM-CSR, Garment Manufacturing Company

13. Findings and Discussions

The study focuses on how social satisfiers have an impact to sustainability. Based on the outcome of the survey undertaken among the CSR beneficiaries of the selected companies, it is found that the community satisfaction and entity satisfaction have no significant relationship with the sustainability of CSR initiatives of companies.

Social harmony strategy takes a communitarian oriented perspective and Selznick (1994) and Carroll (1991) argue that CSR initiatives should focus on, among others, ethical and philanthropic approaches. Both Carroll (1991) and Freeman (1994) suggest CSR initiatives focusing on social antecedents leads to the satisfaction within the community and entity satisfaction. Most importantly, according to the study the sample did not identify much

of a relationship to the sustainability of a company's CSR initiatives. According to the researcher, this may be due to many reasons, such as: the lack of importance of CSR initiatives, lack of relevance attached to CSR initiatives, the belief of the beneficiaries that these program may or may not be sustainable (for example like the questions raised under community satisfaction "I believe current CSR programs of the company satisfy the community needs" the mean and standard deviation values are very low compared to other questions in the section) etc., At the same time, beneficiaries are not the party to decide the sustainability of the programs as it is at the discretion of the managers to decide.

14. Limitations and Recommendations

The research faced many difficulties in pursuing the study and to highlights the major points as insufficient knowledge about what CSR is among corporate entities in Sri Lanka (SL), the size of the population is limited due to the infancy of this concept in Sri Lanka and the non-availability of a knowledgeable appointed person for CSR programs in companies led to the elimination of some companies from the study.

This current study was focused mainly on a developing country, especially one with a market with high growth potential. The reason for this is due to the country is emerging after a long civil war, therefore, the outcome of the research may not be suitable for application to all developing countries across the globe. Therefore, the future researcher can use the same model to observe the implications in other situations.

15. Conclusion

This paper aims to determine whether the social satisfiers such as entity and community satisfactions lead to sustainability of corporate social responsibility projects; especially within an environment where economic wounds are still being healed and new opportunities are evolving within a society that has endured civil unrest for over 30 years. It is found that the community satisfaction and entity satisfaction have no significant relationship with the sustainability of CSR initiatives of companies. Although the author finds the importance of the level of satisfaction the above two entities need to achieve, it is found that it does not lead to the sustainability of those.

References

- Ackerman, R. (1975). *The social challenge to business*. Harvard University Press.
- Barnett, M., & Salomon, R. (2006). Beyond Dichotomy: The Curvilinear Relationship Between Social Responsibility and Financial Performance. *Strategic Management Journal*, 1122(September), 12. <http://doi.org/10.1002/smj>
- Bennett, R. (1996). *Corporate Strategy and Business Planning*. London: Bennett, R.
- Bhattacharya, C. B., Korschun, D., & Sen, S. (2009). Strengthening Stakeholder–Company Relationships Through Mutually Beneficial Corporate Social Responsibility Initiatives. *Journal of Business Ethics*, 85(S2), p. 257–272. <http://doi.org/10.1007/s10551-008-9730-3>
- Bhattacharya, C. B., & Sen, S. (2004). Doing Better at Doing Good: When, Why, and How Consumers Respond to Corporate Social Initiatives. *California Management Review*, 47(1), p.9–24. <http://doi.org/10.2307/41166284>
- Bhattacharya, C. B., Sen, S., & Korschun, D. (2008). "Using Corporate Social Responsibility to Win the War for Talent." *MIT Sloan Management Review*, 49(2), p.37–44. <http://doi.org/10.1007/s10551-008-9812-2>
- Carroll, A. B. (1979). A Three-Dimensional Conceptual Model of Corporate Performance. *The Academy of Management Review*. <http://doi.org/10.2307/257850>
- Carroll, A. B. (1979). A Three-Dimensional Conceptual Model of Corporate Performance. *Academy of Management Review*. <http://doi.org/10.5465/AMR.1979.4498296>
- Carroll, A. B. (1991). The Pyramid of Corporate Social Responsibility: Toward the Moral Management of Organizational Stakeholders. *Business Horizons*. [http://doi.org/10.1016/0007-6813\(91\)90005-G](http://doi.org/10.1016/0007-6813(91)90005-G)
- Carroll, A. B. (1999). Corporate Social Responsibility: Evolution of a Definitional Construct. *Business & Society*, 38(3), p. 268–295. <http://doi.org/10.1177/000765039903800303>
- Dennis, B. A., Buchholtz, A. K., & Butts, M. M. (2009). The nature of giving: A theory of planned behavior examination of corporate philanthropy. *Business & Society*, 48, 360-384.
- Drucker, P. (1954). *The Practice of Management*. Foresman and Company.
- Du, S., Bhattacharya, C. B., & Sen, S. (2007). Reaping Relational Rewards from Corporate Social Responsibility: The Role of Competitive Positioning. *International Journal of Research in Marketing*, 24(3), p.224–241. <http://doi.org/10.1016/j.ijresmar.2007.01.001>
- Edwards, J. R., & Bagozzi, R. P. (2000). On the Nature and Direction of Relationships between Constructs and

- Measures. *Psychological Methods*, 5(2), p. 155–174. <http://doi.org/10.1037/1082-989X.5.2.155>
- Eells, R. S. F., & Walton, C. C. (1961). *Conceptual foundations of business: an outline of major ideas sustaining business enterprise in the Western World*. RD Irwin.
- Enquist, B., Johnson, M., & Skålén, P. (2006). Adoption of Corporate Social Responsibility – Incorporating a Stakeholder Perspective. *Qualitative Research in Accounting & Management*, 3(3), p.188–207. <http://doi.org/10.1108/11766090610705399>
- Freeman, R. E. (1984). *Strategic Management: A Stakeholder Approach. Analysis* (Vol. 1). <http://doi.org/10.2139/ssrn.263511>
- Freeman, R. E. (1994). Ethical Theory and Business. *Prentice Hall, Englewood Cliffs* Frey B. (1997) *The Legal and Ethical Responsibilities of Transnational Corporations in the Protection of International Human Rights. Minnesota J Global Trade*, 6, 153188 Frynas.
- Freeman, R. E. (1999). Divergent Stakeholder Theory. *Academy of Management Review*, 24(2), p.233–236.
- Freeman, R. E., Wicks, A. C., & Parmar, B. (2004). Stakeholder Theory and “The Corporate Objective Revisited.” *Organization Science*, 15(3), p.364–369.
- Friedman, M. (1970). The Social Responsibility of Business is to Increase its Profits. *The New York Times Magazine*, (32), September 13.
- Friedman, M. (1998). The Social Responsibility of Business Is to Increase Its Profits. *The New York Times Magazine*, (32), September 13. http://doi.org/10.1007/978-3-540-70818-6_14
- Galbreath, J. (2009). Building Corporate Social Responsibility into Strategy. *European Business Review*. <http://doi.org/10.1108/09555340910940123>
- Hung Chen, C. (2011). The Major Components of Corporate Social Responsibility. *Journal of Global Responsibility*, 2(1), p.85–99. <http://doi.org/10.1108/20412561111128546>
- Jensen, M. C. (1998). Foundations of organizational strategy. *Business*, 1–7.
- Kariyapperuma, K. A. N. R. (2011). Level of Corporate Social Responsibility Involvement of Sri Lankan Business Organizations: Special Study on Insurance Industry. In *Proceedings of International Conference on Business Management*.
- Kok, P., Van Der Wiele, T., McKenna, R., & Brown, A. (2001). A Corporate Social Responsibility Audit within a Quality Management Framework. *Journal of Business Ethics*, 31(4), p.285–297.
- Kotler, P. (2011). Reinventing Marketing to Manage the Environmental Imperative. *Journal of Marketing*, 75(4), p. 132–135. <http://doi.org/10.1509/jmkg.75.4.132>
- Kotler, P., & Armstrong, G. (2005). *Principles of Marketing*. Prentice-Hall.
- Kotler, P., Keller, K., Brady, D. M., Goodman, M., & Hansen, M. T. (2009). *Marketing Management*. Pearson;
- Kulik, T. (1999). *The Expanding Parameters of Global Corporate Citizenship*.
- Lantos, G. P. (2001). The Boundaries of Strategic Corporate Social Responsibility. *Journal of Consumer Marketing* (Vol. 18). <http://doi.org/10.1108/07363760110410281>
- Kellie Likert, Karen Mass (2016), Strategic Philanthropy, Business and Society, Vol.55(6), 889-921
- Mahalanobis, P. C. (1936). On the Generalized Distance in Statistics. In *Proceedings of the National Institute of Sciences* (p. 49–55).
- Maignan, I. (2001). Consumers’ Perceptions of Corporate Social Responsibilities: A cross-cultural comparison. *Journal of Business Ethics*, p.57 – 72. <http://doi.org/10.2307/25074480>
- Maignan, I., & Ferrell, O. C. (2004). Corporate Social Responsibility and Marketing: An Integrative Framework. *Journal of the Academy of Marketing Science*, 32(1), p. 3–19. <http://doi.org/10.1177/0092070303258971>
- Maignan, I., Ferrell, O. C., & Ferrell, L. (2005). A Stakeholder Model for Implementing Social Responsibility in Marketing. *European Journal of Marketing*, 39(9/10), p. 956–977. <http://doi.org/10.1108/03090560510610662>
- Maignan, I., Ferrell, O. C., & Hult, G. T. M. (1999). Corporate Citizenship: Cultural Antecedents and Business Benefits. *Journal of the Academy of Marketing Science*, 27(4), p.455–469. <http://doi.org/10.1177/0092070399274005>
- Masaka, D. (2008). Why Enforcing Corporate Social Responsibility (CSR) is morally questionable.
- Oliver, C. (1991). Strategic Responses to Institutional Processes. *Academy of Management Review*, 16(1), p.145–179. <http://doi.org/10.5465/AMR.1991.4279002>
- Orlitzky, M., Schmidt, F. L., & Rynes, S. L. (2003). Corporate Social and Financial Performance: A Meta-Analysis. *Organization Studies*, 24(3), p. 403–441. <http://doi.org/10.1177/0170840603024003910>
- Porter, M. E. (1980). Competitive Strategy: Techniques for Analyzing Industries and Competitors. *Competitive Strategy*, 1, 396. <http://doi.org/10.1002/smj.4250020110>
- Porter, M. E. (1985). *Competitive Advantage. Strategic Management* (Vol. May-June).

- <http://doi.org/10.1108/eb054287>
- Porter, M. E. (1990). *The competitive advantage of nations*. *Harvard business review* (Vol. 68). New York: Free Pres.
- Porter, M. E., & Kramer, M. R. (2002). The Competitive Advantage of Corporate Philanthropy. *Harvard Business Review*, 80(12), p.56–68, 133. <http://doi.org/10.1177/0007650306297941>
- Prahalad, C. K. K., & Hamel, G. (1990). The Core Competence of the Corporation. *Harvard Business Review*, 68(3), p. 79–91. http://doi.org/10.1007/3-540-30763-X_14
- Rathnasiri, H. C. H. (2003). Corporate Social Responsibility Practices of Sri Lankan Private Sector: An exploratory study. *Sri Lankan Journal of Management*, p.195–228.
- Reich, R. B. (1998). The New Meaning of Corporate Social Responsibility. *California Management Review*, 40(2).
- Roberts, J. (2003). The Manufacture of Corporate Social Responsibility: Constructing Corporate Sensibility. *Organization*, 10(2), p.249–265. <http://doi.org/10.1177/1350508403010002004>
- Roberts, P. W., & Dowling, G. R. (2002). Corporate Reputation and Sustained Superior Financial Performance. *Strategic Management Journal*, 23(12), p.1077–1093. <http://doi.org/10.1002/smj.274>
- Sekaran, U. (2006). *Research methods for business: A skill building approach*. John Wiley & Sons.
- Sekaran, U., & Bougie, R. (2010). *Research Methods for Business: A Skill Building Approach* (5, illustr). John Wiley & Sons.
- Sen, S., & Bhattacharya, C. B. C. B. (2001). Does Doing Good Always Lead to Doing Better? Consumer Reactions to Corporate Social Responsibility. *Journal of Marketing Research*, 38(2), p.225–243. <http://doi.org/10.1509/jmkr.38.2.225.18838>
- Sen, S., Bhattacharya, C. B., & Korschun, D. (2006). The Role of Corporate Social Responsibility in Strengthening Multiple Stakeholder Relationships: A Field Experiment. *Journal of the Academy of Marketing Science*, 34(2), p.158–166. <http://doi.org/10.1177/0092070305284978>
- Sen, S., Du, S., & Bhattacharya, C. B. (2009). *Building Relationships through Corporate Social Responsibility*, *In Handbook of Brand Relationships in Handbook of Brand Relationships*. (D. J. MacInnis, C. W. Park, & J. R. Priester, Eds.). M.E. Sharpe.
- Scherer, A. G., Palazzo, G., & Matten, D. (2014). The Business Firm as a Political Actor a New Theory of the Firm for a Globalized World. *Business & Society*, 53, 143-156.
- Sutton, M. (2003). Between a Rock and a Judicial Hard Place: Corporate Social Responsibility Reporting and Potential Legal Liability Under *kasky v. nike*. *UMKC L. Rev.*, 1159.
- Tabachnick, B. G., & Fidell, L. S. (2007). Using Multivariate Statistics. *Using Multivariate Statistics 5th Ed*, 980. <http://doi.org/10.1037/022267>
- Waddock, S. a., & Graves, S. B. (1997). The Corporate Social Performance-Financial Performance Link. *Strategic Management Journal*, 18(4), p. 303–319. [http://doi.org/10.1002/\(SICI\)1097-0266\(199704\)18:4<303::AID-SMJ869>3.3.CO;2-7](http://doi.org/10.1002/(SICI)1097-0266(199704)18:4<303::AID-SMJ869>3.3.CO;2-7)
- Weeden, C. (1998). *Corporate Social Investing: The Breakthrough Strategy for Giving & Getting Corporate Contributions*. Berrett-Koehler Publishers.