

# Decision Support Systems and its Impact on Organization Empowerment Field Study at Jordanian Universities

Dr. Fayez Jomah Alnajjar (Associate Professor)

*Department of Management Information Systems, Jadara University, Irbid, Jordan*

Irbid -Jordan P.O. Box: (733) Irbid, Postal code # (21110)

Telephone: 00962 2 (7201222), Mobile (00962-777406117), Fax. 00962 2 (7201210)

E-mail: najjar\_fayez@yahoo.com

Dr. Majed Radi Al-Zoubi (Assistant Professor)

Department of Administrative and Financial science, Al-Balqa Applied University, Jordan

Irbid University College. P.O.Box (1293). Telephone:( 00962-795729281)

E-mail: dr\_majed@yahoo.com

## Abstract

The concept and applications of Decision support systems (DSS) help companies to make better business decisions in order to attain the organizational objectives in an efficient way. Ample evidence indicated that building empowerment is important for having access to information and resources, thinking critically, being effective, create effecting change and building confidence. The study aims to identify the level of DSS applications and empowerment in the Jordanian universities, as well analyzing the impact of decision support systems on empowerment. The study developed a conceptual framework that consists of two parts which simulate the study model. The target population of the study comprised of all faculty members in the colleges of economics and business in the Jordanian universities (state and private). An equal stratified random sampling of (5) public universities and (5) private ones were taken, (150) surveys were distributed, (142) surveys were included in the analysis, (38) items were designed based on previous studies to meet the study objectives. The Study revealed that DSS generators had a significant effect at level ( $P \leq 0.05$ ) on organization empowerment in the Jordanian universities, also the study found a statistically significant effect of DSS generators on personal and collective empowerment in the Jordanian universities.

**Keywords:** Information systems, Decision support systems, Organization empowerment, Jordanian universities.

## 1. Introduction

A Decision Support System (DSS) is an interactive computer based system that help decision-makers use data and models to solve structured, unstructured or semi-structured problems (Gore, 1983). Decision support systems can aid human cognitive deficiencies by integrating various sources of information, providing intelligent access to relevant knowledge, and aiding the process of structuring decisions, they can also support choice from among well-defined alternatives (Castro-Schez, Jimens, Moreno, & Rodringues, 2005). Thus, decision support systems will adopt to any changes or demand from the market due to any improvement in the world of technology and the ongoing evolving economy; to respond efficiently and quickly to decision makers and facilitate the decision process, it enhances organization empowerment, either in person or group's ability to make decisions.

## 2. Objectives of the study

The study aims to identify the level of DSS applications and empowerment in the Jordanian universities, as well analyzing the impact of decision support systems on empowerment.

### 3. Problem of the study

The problem of the study reflects the rapid development in technology and information systems, and whether the Jordanian universities are able to take advantage of this. Meanwhile to what extent Jordanian universities have benefited from the decision support systems in influencing empowerment; where empowerment plays a major role in the ability of universities to progress and development.

g

### 4. Theoretical Background

#### 4.1 Decision Support Systems

The concept of an interactive computer-based system that helps companies make better business decisions has been around since computers came into widespread use.

The vision is deceptively simple. Companies work hard on gaining competitive advantage through building a deep understanding of the challenging relationship between organization and its environment (Al-Zoubi, 2012, 237). They take advantage of in-depth reporting tools and predictive models to analyze data and learn what happened in their business, why it happened and, eventually, what will happen. This yields a deep, fact-based understanding that complements experience and intuition which leads to exemplary decision-making and dramatic competitive advantage (Jessani, 2003).

Decision Support Systems (DSS) are a specific class of computerized information system that supports business and organizational decision-making activities. A properly designed DSS is an interactive software-based system intended to help decision makers compile useful information from raw data, documents, personal knowledge, and/or business models to identify and solve problems and make decisions (Broun, 2012). It provides information for making semi structured and unstructured decisions by the middle management (Khan & Khan, 2011). It's a decisive system for universities to gain a sustainable competitive advantage by moving beyond customers satisfactions to build positive change in the surrounded environment, practical academic programs, confidence and improving quality of education.

##### 4.1.1. Model-driven DSS generators

There are five more specific Decision Support System types include:

4.1.1.1. A data-driven DSS or data-oriented DSS emphasizes access to and manipulation of a time series. In statistics, signal processing, and many other fields, a time series is a sequence of data points, measured typically at successive times, spaced at time intervals... of internal company data and, sometimes, external data. The data-driven DSS enables you to cost effectively target customers that are most likely to respond. It helps you more clearly understand the customers you have been targeting, the customers you need to target, and what you can change to improve the targeted mailings (Jessani, 2003).

4.1.1.2. A communication-driven DSS supports more than one person working on a shared task; examples include integrated tools like Microsoft's Net Meeting or Groove (Stanhope, 2002).

4.1.1.3 A document-driven DSS can help managers to retrieve and manage unstructured documents and web pages by integrating a variety of storage and processing technologies to provide complete document retrieval and analysis. It also access documents such as company policies and procedures, product specification, catalogs, corporate historical documents, minutes of meetings, important correspondence, corporate records, etc. and are usually driven by a task-specific search engine (Fedorowics, 1993)

4.1.1.4. Model – driven DSS emphasizes access to and manipulation of a statistical, financial, optimization, or simulation model. Model-driven DSS use data and parameters provided by users to assist decision makers in analyzing a situation; they are not necessarily data-intensive (Gachet, 2004).

4.1.1.5. A knowledge-driven DSS provides specialized problem-solving expertise stored as facts, rules, procedures, or in similar structures. Knowledge management systems (KMS) are systems designed to support organizational knowledge processes. Knowledge-oriented theories of the firm are emerging, as theories of KMS design continue to evolve (Richardson, Courtney & Haynes, 2006)

#### 4.1.2. Decision Support Systems advantages (University of Stirling, 2004).

4.1.2.1. Improves personal efficiency.

4.1.2.2. Expedites problem solving.

4.1.2.3. Facilitates interpersonal communication.

4.1.2.4. Promotes learning or training.

4.1.2.5. Increases organizational control.

Based on the previous principles, the main role of decision support systems is to provide support to decision maker in the academics organizations, which give the leadership a big space to address a complex issues by building a successful strategies based on the exploiting the ongoing IT innovative systems and the internet expansion.

#### 4.2. Empowerment

Ample evidence shows that the development of any nation depends on its educational system; also it is proved that education is the corner stone to nation's progress and social improvement toward change and prosperity. But how we can apply empowerment approach on universities, so that faculties can fully utilize their innovative potential as well engaging in innovative teaching, learning and researching?

According to Business Dictionary (2012), Empowerment is based on the idea that giving employees skills, resources, authority, opportunity, motivation, as well holding them responsible and accountable for outcomes of their actions, will contribute to their competence and satisfactions. Fox (1998) defines it as a process of risk taking, growth, change, understanding the employee's needs and team work as a whole. Thomas & Velthouse (1990) looked at empowerment concept as a psychological process containing cognitive – motivation, such as self-authorized, sense of meaning, and sense of being effective. Therefore, empowerment approach is expected to help building confidence, exerting capacities and encouraging talented ideas in individuals and organizations to take control of and make the change in the academic field and the society as well.

Empowerment is not simply sharing power but distributing power (Hollander & Offerman 1990). Theorists such (Spreitzer, 1995; Thomas & Velthouse, 1990) have identified perceived empowerment to include four components: (a) the work has personal meaning for the employee, (b) the employee feels competent in the ability to perform the task, (c) the employee has a degree of self-determination in his or her ability to choose and regulate task action, and (d) the employee feels the work has impact beyond the immediate job. Lee (1991) has clarified the concept by defining teacher empowerment as the development of an environment in which the teachers act as professionals and are treated as professionals.

Accordingly, we can see that Empowerment leads to sense of ownership and authority delegation; it represents management theory of power and delegation that granted rights and legitimacy to control and direct organizational resources to hit the desired target.

Based on pervious thoughts and definition, reaching active empowerment environment requires adopting certain blocks such as: Having access to information and resources, thinking critically, being effective, create effecting change and building confidence.

##### 4.2.1. Organization Empowerment

Empowerment can be separated into two categories which are interrelated: Personal empowerment, Group empowerment. Generally, Decision Support systems is expected to improve decision-making activities, and Organization empowerment to reach their objectives efficiently.

##### 4.2.1.1. Personal Empowerment

Personal empowerment states that true empowerment cannot come from merely feeling empowered but must involve real world evidence of our ability to have an impact on our relationships and social surroundings, it requires increasing our actual influence within our social sphere (Winch, 2011)

4.2.1.2. Group Empowerment: Build strength, increase and develop the strength through collective cooperation, partnership and work together (Al-addar, 2012). This breed of DSS is often called group decision support systems (GDSS). They are a special type of hybrid DSS that emphasizes the use of communications and decision models intended to facilitate the solution of problems by decision makers working together as a group (Sauter, 2002).

#### 4.3. Jordanian Universities

Jordan University in Amman is first university was established in 1962. but today the number of universities in Jordan are 30 universities, including 10 public universities and 20 private universities (Ministry of Higher Education and Scientific Research, 2012).

### 5. Previous Research

Haghighi & Ali (2011) investigated Employee empowerment: Functions of Tehran Education Organization. The objective of the research was to investigate the employees' empowerment functions of Tehran education organization. The research's method is the descriptive survey method. All employees of the city of Tehran's education organization whom add up to 586 people form its statistical population, samples were selected according to Morgan table which has been 230 person. Questionnaire, which has been made by researcher, was used for gathering information. The results showed that there is a meaningful relationship between empowerment and motivational factors, increase staff confidence, strengthening cordiality and honesty of employees, increasing efficiency partnership and teamwork, strengthening communication, increasing information, knowledge and skills of employees, optimizing work flow and procedures.

Yazdani, Yaghoubi & Giri (2011), drew their study on Factors affecting employee empowerment in Sistan and Baluchestan University- Iran and introduces strategies to improve it. In this regard, research describe approaches, effective factors and dimensions, and investigate different ways of empowerment as well. The study evaluates job enrichment, devolution, performance-based rewards, participative management, suggestion system, team-work formation and participation in goal-setting as the main ways of empowerment. Meanwhile, the results confirmed all of the above categories. Finally, a model is proposed for employee empowerment by using the results.

Lee, Wagner & Shin (2008) performed an empirical investigation into the effect of users' decision support system (DSS) expertise on their problem-solving strategies. The results indicated that individuals who had only recently learned to use the DSS were confused or restricted by the set of functions provided by the system and did not plan well for their use of the DSS. Those who had previous knowledge of the system exhibited more focused and efficient problem-solving behavior. Our findings suggested that problem-solving strategies depended significantly on the user's level of system expertise.

Hung, Ku, Liang & Lee (2007) assessed how the value of decision support systems (DSS) is an important line of research. Traditionally, researchers adopt user satisfaction and decision performance to measure DSS success. In some cases, however, the use of DSS is not benefit driven. Instead, DSS adoption may be motivated by avoiding decision errors or reducing decision cost, indicating that regret avoidance may be a useful measure of DSS success. This exploratory study extends prior research on DSS evaluation by proposing regret avoidance as an additional measure of DSS success. Experimental results regarding the use of DSS for stock investment demonstrate DSS use significantly reduces regret in situations involving low user satisfaction. Consequently, besides decision performance and user satisfaction, regret reduction is also important in measuring the effectiveness of DSS.

Michael, Dennis, Stam & Aronson (2007) uses a laboratory experiment to examine the effect of DSS use on the decision maker's error patterns and decision quality. The DSS used in our experiments is the widely used Expert Choice (EC) implementation of the Analytic Hierarchy Process. Perhaps surprisingly, our experiments do not provide general support for the often tacit assumption that the use of a DSS such as EC improves decision quality. Rather, we find that, whereas a DSS can help decision makers develop a better understanding of the essence of a decision problem and can reduce logical error (especially if the information load is high), it is also susceptible to introducing accidental effects such as mechanical errors. In some cases, as in our study, the accidental errors may outweigh the benefits of using a DSS, leading to lower quality decisions.

Barr & Sharda (1997) design their study to the study proposes that effects of DSS on decision outcomes develop over time. The study evaluated whether improvements in decision quality typically associated with DSS were due primarily to 'development' or 'reliance' effects. Using an add-on and take-away design, we examined whether introduction of DSS contributes to decision quality after controlling for task familiarity. We also evaluated decision-makers' performance after removing the DSS. Results indicated that although DSS contributed to decision quality after controlling for task familiarity, increased decision performance of DSS-aided decision makers may be

due to reliance rather than better conceptual understanding of the decision problem. Implications of these results for design and implementation of DSS are discussed.

## **6. Study Questions and Hypotheses.**

### **6.1. Demographic Profile**

Based on table (2) the demographic sample was divided between males (81%) while females (19%), the results also showed that the majority of faculty members are between (40- less than 50 years old), (55.6%) of them are assistant professors, (51.4%) of faculty members employed at private universities. The study showed that (33.8%) of faculty members published (3-5) individual research while (26.1%) of them published collective research. For more details see table (2).

### **6.2. Questions of the Study**

6.2.1. What is the application level of DSS in the Jordan universities?

6.2.2. What is the actual empowerment in the Jordanian Universities?

6.2.3 Is there an impact of DSS generators on empowerment in the Jordanian Universities?

### **6.3. Hypotheses of the Study**

H<sub>1</sub>: There is no significant impact of decision support systems on personal empowerment in the Jordanian universities.

H<sub>2</sub>: There is no significant impact of decision support systems on collective empowerment in the Jordanian universities.

H<sub>3</sub>: There is no significant impact of decision support systems on organization empowerment in the Jordanian universities.

### **6.3. Proposed Frame Work of the Study**

The study developed a conceptual framework that consists of two parts which simulate the study model as shown in figure (1). The first part of the model represents the DSS generators, while the second part represents the organization empowerment.

## **7. Research Method**

### **7.1. Type and nature of the study**

This study is explanatory in purpose as they seek to know the effect of decision support systems on empowerment in the Jordanian universities

### **7.2. Population and the study sample**

The target population of the study comprised of all faculty members in the colleges of economics and business in the Jordanian universities (state and private). Official statistical sources of the Ministry of Higher Education in Jordan indicated a total number of (30) universities, (10) are state universities and (20) are private universities. An equal stratified random sampling of (5) public universities and (5) private ones. (15) Surveys were distributed to each university accumulating (150) ones. (142) surveys were included in the analysis.

### **7.3. Unit of analysis**

Faculty members in the colleges of economics and business in the Jordanian universities.

### **7.4. Source of Data**

Secondary data was collected based on the findings of prior studies, published articles, books and the World Wide Web. Nevertheless, the primary data collection was carried out using a questionnaire to serve the aim of the study.

### **7.5. Study Instrument.**

A questionnaire survey was adopted to collect the primary data in this study, the questionnaire comprises three sections: the first section covers the demographic information, the second section represent the DSS questions which rely on previous studies, (20) items were selected depending on model-driven DSS generator as follow: A data-driven DSS (1-4), A communication-driven DSS (5-8), A document-driven DSS (9-12), Model – driven DSS (13-16), A knowledge-driven DSS (17-20). The third section consist of (18) items representing organizational Empowerment: Personal Empowerment (21—29), and Group empowerment (30-38), which has been relying on Chamberlan (2011), in determining the questions of empowerment. The statistical weights of the survey were: 5 indicate strongly agree while 1 indicates strongly disagree. For more details see table (8).

#### *7.6. Validity and Reliability of Data*

To ensure the face validity of the instrument tool, the survey was given to five expert referees from Jordanian Universities. The referees displayed their constructive comments and suggestions, which were taken into consideration. However, the reliability test was conducted to Cronbach alpha correlation in each of the variables in the questionnaire. Cronbach alpha for Independent Variable = (0.9617), while for dependent Variable = (0.9679) which exceeded the acceptable limit. For more details see table (1).

#### *7.7. Data Analysis*

The following tools were used to test the hypothesis: frequencies, means, percentages and standard deviation were used as descriptive analysis to meet the study questions, while simple regression (enter) was used to test the first and second hypothesis. Multiple regression (stepwise regression) was calculated to asses the impact of DSS generators on organization empowerment and specifying which generator has the strongest impact on empowerment.

### **8. Statistical Analysis and Hypotheses Testing**

#### ***8.1. The Statistical Results of Study Questions***

##### **8.1.1. What is the application level of DSS in the Jordan universities?**

As can observed from Table (3), the mean value for each variable of the DSS generators varies from as low as (2.57) for a communication–driven DSS to as high as (2.82) for a document-driven and Model driven DSS for the academics sample involved. The standard deviation for these variables ranges from (0.81) to (0.93).The result implies moderate applications for experiencing the DSS generators in the Jordanian universities.

##### **8.1.2. What is the actual empowerment in the Jordanian Universities?**

Table (4) showed that the mean value for personal empowerment is (2.86), while for group empowerment is (2.98). Also, the mean value for organization empowerment was (2.92). The standard deviation for these variables ranges from (0.87 to 0.92). The results imply moderate applications for experiencing the organization empowerment in the Jordanian universities.

#### **8.2. The Results of Hypotheses Testing**

**H<sub>0</sub> 1:** There is no significant impact of decision support systems on personal empowerment in the Jordanian universities.

Table (5) depicts the impacts of DSS generators on the personal empowerment. As tabulated, it was discovered that the value of R<sup>2</sup> for DSS model generators is (0.51) and ( $f= 146.872, P= 000$ ) which explain (51%) of variance in personal empowerment. Therefore, DSS generators was found to have a significant and positive effect on personal empowerment, the regression coefficient for DSS generators ( $\beta =0.716, P= 000$ ). Based on the result we can't accept the null hypothesis and accept the research hypothesis that indicates a significant impact of DSS generators on personal empowerment in the Jordanian universities at level of ( $P\leq 0.05$ ).



**H<sub>0</sub> 2:** There is no significant impact of decision support systems on collective empowerment in the Jordanian universities.

Table (6) depicts the impacts of DSS generators on the group empowerment. As tabulated, it was discovered that the value of  $R^2$  for DSS model generators is (0.42) and ( $f= 101.508, P= 000$ ) which explain (42%) of variance in group empowerment. Therefore, DSS generators was found to have a significant and positive effect on personal empowerment, the regression coefficient for DSS generators ( $\beta = 0.648, p=000$ ). Based on the result, we can't accept the null hypothesis and accept the research hypothesis that indicates a significant impact of DSS generators on group empowerment in the Jordanian universities at level of ( $P \leq 0.05$ ).

**H<sub>0</sub> 3:** There is no significant impact of decision support systems on organization empowerment in the Jordanian universities.

As for the third hypothesis as showed in (table 7) by using multiple regression (stepwise regression), it was found that  $R^2$  value for communication-driven DSS is (0.423) and ( $f=102.6, P = 000$ ), which explained (42.3%) of variance in organization empowerment, in addition to that ( $\beta = 0.65, P= 000$ ). Then it was discovered that  $R^2$  value for communication and model driven DSS together is (0.474), which implies that explained (47.4%) of variance in organization empowerment, in addition beta value of communication driven DSS is ( $\beta = 0.374, P= 000$ ), and model driven DSS is ( $\beta = 0.357, P= 000$ ). Finally, it was discovered that  $R^2$  value for communication, model and knowledge driven DSS together is (0.489) and ( $f= 44.02, P= 000$ ) which explained (48.9%) of variance in organization empowerment, in addition beta value of communication driven DSS is ( $\beta = 0.265, P= 0.018$ ), model driven DSS is ( $\beta = 0.300, P= 0.003$ ) and knowledge driven DSS ( $\beta = 0.199, P= 0.049$ ). Based on the result we can't accept the null hypothesis and accept the major research hypothesis that indicates a significant impact of DSS generators on organization empowerment in the Jordanian universities at level of ( $P \leq 0.05$ )

## 9. Conclusion and Recommendations

The findings of this empirical study confirmed the following:

- The study found that the majority of Jordanian faculty are: male (81%), while (78.2%) are less than (50) years old of age, (55.6%) of them are assistant professors and (48.6%) are working in private universities.
- The study indicated that (33.8%) of the sample published (3-5) individual papers for the last five years, and (33.1%) of the sample published (1-2) collective papers.
- The study revealed that DSS applications level is moderate in the Jordanian universities, with mean value of (2.75)
- The study revealed that organization empowerment application's level is moderate with mean value of (2.92).
- The study found a statistically significant effect of DSS generators on personal empowerment in the Jordanian universities.
- The study found a statistically significant effect of DSS generators on group empowerment in the Jordanian universities.
- The Study revealed that DSS generators had a significant effect at level ( $P \leq 0.05$ ) on organization empowerment in the Jordanian universities.

**Based on the study findings, the authors make the following recommendations:**

- Universities are urged to embody the DSS generator's culture along the organization structure to fully exploit the organizational resources.
  
- Improving empowerment applications level in academic's environment to enlarge commitment and distribute responsibilities.
  
- Jordanian universities are highly encouraged to support and build research centers in the universities to gain significant impacts in the external environment as well in the universities.
  
- To enhance the collective research by improving the academics' systems and instructions.
  
- Empowering women to enter collective research in the Jordanian universities.
- To enhance the electronics culture in the Jordanian universities by offering training courses to academics and concentrate on applications' courses for students.

**10. References**

- AL-Addar, M.A. (2012). *How to lead employees to success*. HRD Pioneers, Available at: <http://www.hr pioneers.com/articles/view/38>
- Al-Zoubi, Majed Radi (2012). Leadership competencies and competitive advantage: empirical study on Jordan telecommunications. *European Journal of Business and Management*, (4)7, pp. 234-247. Available at: <http://www.iiste.org/Journals/index.php/EJBM/article/view/1832>
- Barr, Steve H., & Sharda, Ramesh (1997). Effectiveness of decision support systems: development or reliance effect? *Decision Support Systems*, (21)2, pp. 133-146
- Business dictionary* (2012). Available at: [www.businessdictionary.com/definition/empowerment.html#ixzz1q25IRi7Z](http://www.businessdictionary.com/definition/empowerment.html#ixzz1q25IRi7Z)
- Broun, Adrain (2012). *Decision support systems – DSS definition*. Information Builders: Business Intelligence and Integration Without Barriers. Available: <http://www.informationbuilders.com/decision-support-systems-dss>
- Castro-Schez, J.J. Jimens, L. Moreno, J. & Rodringues, L. (2005). Using fuzzy reporting table –based technique for decision support. *Decision Support Systems*, 39, 293-307. Available at: <http://oreto.esi.uclm.es:9673/oreto/Publicaciones/jjcastrodss05/Adjunto>
- Fedorowics, J (1993). *A technology infrastructure for document based decision support systems*. Sprague: Prentice Hall.
- Fox, J. (1998). *Employee empowerment: An apprenticeship model*. Barney School of Business University Hartford, Available at: [http:// members: tripod. Com](http://members.tripod.com).
- Gachet, A. (2004). *Building model-driven decision support systems with decodes*. Zurich, VDF.



Gore, Marvin (1983). *Elements of systems analysis*. Dubuque, Iowa: Brown Co. Publishers. pp62-67.

Haghighi1, Masoud & Ali, Mahrokh (2001). Employee empowerment: Functions of Tehran Education Organization, *International conference on management (ICM) Proceeding*. Available at: <http://www.internationalconference.com.my/proceeding/icm2011>.

Hollander, E. P., & Offerman, L. R. (1990). Power and leadership in organizations: Relationships in transition. *American Psychologist*, 45, 179-189.

Hung, Shin-Yuan, Ku, Yi-Cheng, Liang, Ting-Peng, & Lee, Chang-Jen (2007). Regret avoidance as a measure of DSS success: An exploratory study. *Decision Support Systems*, (42)4, pp.2093-2106.

Jessani, R. (2003). *Creating an Effective Data-Driven Decision Support System*, DSS Resources, COM, 12/05/2003.

Khan, Mohd, & Khan, Farneena (2011). Conceptual over view of MSS and its important in an organization. *Information and Knowledge Management*. (1)2, pp. 15-23. available at: [www.iiste.org](http://www.iiste.org)

Lee, W. (1991). Empowering music teachers: A catalyst for change. *Music Educators Journal*, 78(1), 36-39.

Lee, Zoonky, Wagner, Christian, & Shin, Ho Kyoung (2008). The effect of decision support system expertise on system use behavior and performance. *Information & Management*, (45)6, pp.349-358.

Michael L., Dennis, Alan R., Stam, Antonie, & Aronson, Jay E. (2007). The impact of DSS use and information load on errors and decision quality. *European Journal of Operational Research*, January, pp. 468-481

*Ministry of Higher Education and Scientific Research* (2012). Available at: <http://www.mohe.gov.jo/PrivateUniversities/tabid/64/language/ar-JO/Default.aspx>

Richardson, Sandra M., Courtney, James F., & Haynes, John D. (2006). Theoretical principles for knowledge management system design: Application to pediatric bipolar disorder. *Decision Support Systems*, (42)3, pp. 1321-1337

Stanhope, P. (2002). *Get in the Groove: building tools and peer-to-peer solutions with the Groove platform*. New York: Hungry Minds

Sauter, Vicky L. (2002). *Introduction to decision support systems for business intelligence*. MO: University of Missouri. Available at: [http://www.umsl.edu/~sauterv/analysis/488\\_f02\\_papers/dss.html](http://www.umsl.edu/~sauterv/analysis/488_f02_papers/dss.html)

Spreitzer, G. M. (1995). Psychological empowerment in the workplace: dimensions, measurement, and validation. *Academy of Management Journal*, 38, 1442-1465.

Thomas, K. W., & Velthouse, B. A. (1990). Cognitive elements of empowerment: An interpretative model of intrinsic task motivation. *Academy of Management Review*, (15)4, 666-681.

University of Stirling (2004). *Lecture of DSS, IT62 DSS*. UK. Available at: [http://www.cs.stir.ac.uk/~agh/it62/lectures/lec2\\_dss.pdf](http://www.cs.stir.ac.uk/~agh/it62/lectures/lec2_dss.pdf)

Yazdani, Bader; Yaghoubi, Noor & Giri, Ebrahim (2011). Factors affecting empowerment of employees. *European Journal of Social Sciences*, 20(2),267-274.

Winch, Guy (2011). How to attain real personal empowerment. *Psychology Today*. Available at: <http://www.psychologytoday.com/blog/the-squeaky-wheel/201101/how-attain-real-personal-empowerment>

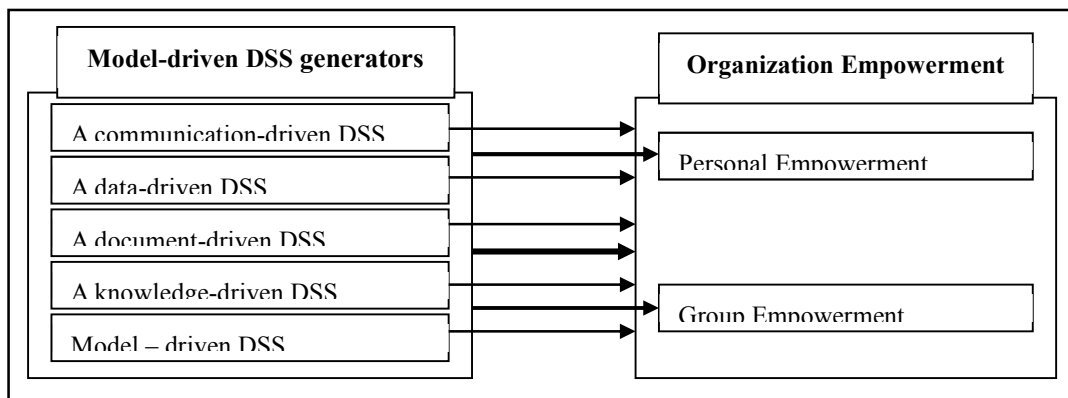

Figure: 1 Model of the study Source: Model prepared by the researchers

Table 1: Reliability coefficient of DSS generators and organization empowerment

No.	Reliability Coefficient	N of Cases = 142		
		Questions	N of Item	Alpha
1	A data-driven DSS	1 - 4	4	0.8881
2	A communication-driven DSS	5 - 8	4	0.8517
3	A document-driven DSS	9 - 12	4	0.8639
4	Model – driven DSS	13 - 16	4	0.8891
5	A knowledge-driven DSS	17 - 20	4	0.8596
	<b>DSS generators</b>	1 - 20	20	0.9617
6	Personal Empowerment	21 - 29	9	0.9391
7	Group Empowerment	30 - 38	9	0.9472
	<b>Organization Empowerment</b>	21 - 38	18	0.9679
	<b>Instrument</b>	1 - 38	38	0.9751

Table 2: Personal characteristic

Demographic Variables		Freq.	%	Demographic Variables		Freq.	%
Gender	Male	115	81	Experience	Less than 5 years	45	31.7
	Female	27	19		5- Less than 10 years	51	35.9
Age	Less than 30 years	14	9.9		10- Less than 15	28	19.7
	30- Less than 40 years	39	27.5		15 years and over	18	12.7
	40- Less than 50 years	58	40.8	Individual research	Nothing	29	20.4
50 Years and over	31	21.8	1-2 Research		42	29.6	
Academic rank	Instructor	25	17.6		3-5 Research	48	33.8
	Assistant Prof.	79	55.6	More than 5 research	23	16.2	
	Associate Prof.	27	19	Collective research	Nothing	39	27.5
	Professor	11	7.7		1-2 Research	47	33.1
University classification	Public	69	48.6		3-5 Research	37	26.1
	Private	73	51.4	More than 5 research	19	13.4	

Table 3: The application level of DSS in the Jordanian Universities

No.	DSS generators	N	Degree of acceptance		
			Questions	Mean	Std.
1	A data-driven DSS	142	1 - 4	2.7183	0.89565
2	A communication-driven DSS	142	5 - 8	2.5775	0.88335
3	A document-driven DSS	142	9 - 12	2.8239	0.89363
4	Model – driven DSS	142	13 - 16	2.8222	0.91654
5	A knowledge-driven DSS	142	17 - 20	2.8116	0.93218
	<b>DSS generators</b>	142	1 - 20	2.7507	0.81094

Table 4: The actual empowerment in the Jordanian Universities

No.	Organization Empowerment	N	Degree of acceptance		
			Questions	Mean	Std.
1	Personal Empowerment	142	21 - 29	2.8685	0.88203
2	Group Empowerment	142	30 - 38	2.9859	0.92422
3	<b>Organization Empowerment</b>	142	21 - 38	2.9272	0.87574

Table 5: Simple regression (enter) of DSS generators on personal empowerment

**Model Summary**

Model	R	R Square	Adjusted R Square	Std. Error of the Estimate
1	.716 <sup>a</sup>	.512	.508	.61837

a. Predictors: (Constant), GENE

**ANOVA<sup>b</sup>**

Model		Sum of Squares	df	Mean Square	F	Sig.
1	Regression	56.161	1	56.161	146.872	.000 <sup>a</sup>
	Residual	53.533	140	.382		
	Total	109.694	141			

a. Predictors: (Constant), GENE

b. Dependent Variable: Personal Empowerment

Table 6: Simple regression (enter) of DSS generators on group empowerment

**Model Summary**

Model	R	R Square	Adjusted R Square	Std. Error of the Estimate
1	.648 <sup>a</sup>	.420	.416	.70619

a. Predictors: (Constant), GENE

**ANOVA<sup>b</sup>**

Model		Sum of Squares	df	Mean Square	F	Sig.
1	Regression	50.622	1	50.622	101.508	.000 <sup>a</sup>
	Residual	69.818	140	.499		
	Total	120.441	141			

a. Predictors: (Constant), GENE

b. Dependent Variable: GROUP

Table 7: Multiple regression (stepwise regression) of DSS generators on organization empowerment

**Model Summary**

Model	R	R Square	Adjusted R Square	Std. Error of the Estimate
1	.650 <sup>a</sup>	.423	.419	.66760
2	.689 <sup>b</sup>	.474	.467	.63946
3	.699 <sup>c</sup>	.489	.478	.63278

- a. Predictors: (Constant), A communication-driven DSS
- b. Predictors: (Constant), A communication-driven DSS, Model - driven DSS
- c. Predictors: (Constant), A communication-driven DSS, Model - driven DSS, A knowledge-driven DSS

**ANOVA <sup>d</sup>**

Model		Sum of Squares	df	Mean Square	F	Sig.
1	Regression	45.740	1	45.740	102.625	.000 <sup>a</sup>
	Residual	62.397	140	.446		
	Total	108.137	141			
2	Regression	51.299	2	25.649	62.727	.000 <sup>b</sup>
	Residual	56.838	139	.409		
	Total	108.137	141			
3	Regression	52.881	3	17.627	44.023	.000 <sup>c</sup>
	Residual	55.256	138	.400		
	Total	108.137	141			

- a. Predictors: (Constant), A communication-driven DSS
- b. Predictors: (Constant), A communication-driven DSS, Model - driven DSS
- c. Predictors: (Constant), A communication-driven DSS, Model - driven DSS, A knowledge-driven DSS
- d. Dependent Variable: ORGA

Table 8: Study survey

No.	Items	Degree of acceptance				
		1	2	3	4	5
1	There is an available database in the university capable of supporting various directions.					
2	The university offers an integrated package of hardware and software to support management decisions.					
3	Decision support systems provide coordination in different strategies and programming activities in support of various university faculties to make the most of the IT infrastructure at the university.					
4	The university uses statistical analysis and forecasting functions of different disciplines whenever opening new programs.					
5	The university is working to integrate information technology with the learning process to enhance the dynamics of teamwork.					
6	The university is using video conferencing technology to discuss the thesis and other activities whenever it's necessary.					
7	There is an available decision support systems based on Internet technology (Internet					

	Web DSS).				
8	The university Supports research teams' groups (internal or external) and provide appropriate support for them.				
9	Decision support systems work on maximize participation in the various resources to achieve the greatest added value.				
10	The university uses a set of (Strategic models databases) such as analysis of the strategic position and performance analysis.				
11	The university uses decision support systems in forecasting and future planning for the expansion of university programs.				
12	The university uses decision support systems to evaluate various investments needed to support the continued operation of the university in a distinct way.				
13	The university uses a set of rules models of different applications such as financial, accounting and marketing applications.				
14	The university uses a set of tactical models databases in various functional areas.				
15	The university uses a set of operational models databases) to support decisions in the structured operational management level.				
16	Decision support systems contribute to the university in building new models and analysis of various alternatives to provide appropriate solutions.				
17	Decision support systems which based on knowledge provide justifications for the proposed solution at the inquiry; thus enhancing confidence in the system and its' proposals.				
18	There is an Available knowledge base and scientific productions include various activities for faculty members and available for everyone to take advantage of them.				
19	The university offers social networking sites for each section in which students can communicate, interact and make suggestions that can be built upon.				
20	The system allows for faculty members to exchange e-mails for the development of the various recommendations.				
21	The University administration works on delegating power to capture certain tasks and activities at the university.				
22	The university administration provides training for staff and advice in the right time.				
23	The university concerns to enable the academics according to their authorities to gain access to relevant information necessary to complete their work.				
24	The university recognizes the significant contributions and achievements made by individuals.				
25	The University encourages the employees to take initiatives and innovation in solving problems.				
26	The university adopts tracking module and a clear guarantee that the rewards provided to an individual fit with the new responsibilities.				



27	The University guarantees the lack of legal accountability in case of mistakes occurred because of initiatives or a new ideas taken by academics.				
28	The university provides various incentives to reward employees with outstanding creativity.				
29	The university is applying rules and regulations in a transparent and clear way on everyone.				
30	The university administration clarifies the objectives to be achieved for academics.				
31	The University administration ensures the appropriate mechanisms to work to achieve the objectives to be achieved.				
32	The University works on involving employees in decisions that affect their work.				
33	The university's administration provides resources needed to implement the new work responsibilities.				
34	The University works on removing bureaucratic restrictions that hamper the work.				
35	The University works on building and enhancing mutual trust and confidence in the academic community.				
36	University councils are formed within clear institutional terms and freedom to make decisions within the powers conferred upon.				
37	The university works on adaptation of management systems to enhance the success of empowerment.				
38	The University guarantees ethical and fair accountability in using force within the law				

This academic article was published by The International Institute for Science, Technology and Education (IISTE). The IISTE is a pioneer in the Open Access Publishing service based in the U.S. and Europe. The aim of the institute is Accelerating Global Knowledge Sharing.

More information about the publisher can be found in the IISTE's homepage:

<http://www.iiste.org>

The IISTE is currently hosting more than 30 peer-reviewed academic journals and collaborating with academic institutions around the world. **Prospective authors of IISTE journals can find the submission instruction on the following page:**

<http://www.iiste.org/Journals/>

The IISTE editorial team promises to review and publish all the qualified submissions in a fast manner. All the journals articles are available online to the readers all over the world without financial, legal, or technical barriers other than those inseparable from gaining access to the internet itself. Printed version of the journals is also available upon request of readers and authors.

### **IISTE Knowledge Sharing Partners**

EBSCO, Index Copernicus, Ulrich's Periodicals Directory, JournalTOCS, PKP Open Archives Harvester, Bielefeld Academic Search Engine, Elektronische Zeitschriftenbibliothek EZB, Open J-Gate, OCLC WorldCat, Universe Digital Library, NewJour, Google Scholar

