

Reduction of Switching Losses in VSC Using DC Link Fuzzy Logic Controller

V.Manoj* K.Manohar, B.Durga Prasad

Department of Electrical and Electronics Engineering, Gitam University, Visakhapatnam 530045, Andhra Pradesh, India

* jonam287@gmail.com

Abstract

The main objective of a soft switching circuit is to reduce the switching losses in a static converter when is switched at high frequency. In this paper a DC link fuzzy logic controller applied to a VSC (voltage source converter). The lossless switching is tested in a parallel VSC and is verified the effect of the soft switching circuit in MATLAB-SIMULINK. During the switching interval some power is dissipated in power transistors. A VSC in parallel to the DC link is added in simulation to show the instantaneous power in any switch.

Keywords: fuzzy logic controller with rule-viewer, dc link, soft switching, voltage source inverter, lossless switching

1. Introduction

Resonant DC link inverters allow soft switching of semiconductor power devices. Soft switching provides an effective means of reducing device stress and switching losses. The term soft switching means the devices are switched only when the voltage across the device and/or current through the device is zero resulting in zero voltage switching (ZVS) or zero current switching (ZCS). The most common soft switching circuits use a LC resonant tank to link the power supply to the switching circuit. Normally the resonant circuit oscillates between zero and twice the supply voltage and ZVS occurs when the link voltage is zero. The switching losses limit the useable switching frequency. For this reason, the reduction of switching losses with resonant or soft switching topologies is necessary. PWM Inverter is an important circuit in Power Electronics and Drives System. Its application includes induction motor drives, AC power supplies and actuation system. For higher output power, typically greater 2kVA, three phase system will be more appropriate. The main use of fuzzy control system is based on empirical rules is more effective. Fuzzy control can be used to improve existing traditional control systems by adding a layer of intelligence to the current control method. The new HVDC system based on the voltage source converters (VSCs) and pulse width modulation (PWM) known as VSC – HVDC shown in figure 1.VSC-HVDC has many advantages compared with the traditional HVDC one advantage is possible support of weak AC systems or even passive systems without phase change voltage.

2. DC Link Model

This model consists of IGBT's, Capacitor and Inductor. The circuit is connected in between supply and VSC to make DC link voltage zero when converter changes its stages. The link consists of three controllable switches and diodes D1,D2,D3. Here L_r and C_r are the resonant components. The voltage (V_{Cr}) and current (I_{Cr}) are the corresponding signals in the capacitor which is given to the fuzzy controller as input..

3. Fuzzy Logic Control

The fuzzy logic controller consists of Fuzzy Inference System Editor. The simulation of soft switching circuit is developed in this FIS editor. V_{Cr} and I_{Cr} are the inputs of the fuzzy controller. The output of the controller is crisp value. This Graphical User Interface consists of FIS Editor, Membership function Editor, Rule Editor, Rule Viewer and Surface Viewer.

4. Soft Switching Scheme Simulink

The soft switching scheme consists of a DC link block and fuzzy controller with Rule Viewer. The output of the DC link VCr and ICr signals are given to the fuzzy controller which generates the activation order of switches in the resonant block. The output of the DC link are showed in figure 10. The crisp output is given to the matlab embedded function block. It generates the timing signals T1, T2, T3 to the IGBT switches in the DC link block.

5. Soft Switching Verification

For the soft switching the fuzzy DC link structure is added to the full bridge converter (AC-DC) in order to reduce the power losses in any switch of the converter. During switching interval some power is dissipated in transistors. In order to reduce this effect, VSC in parallel to the DC link is added to show the instantaneous power in any switch. The VSC is the chosen circuit because it is widely used in all kinds of applications due to its controllability, compact modular design, eases of system interface and low environmental impact. The VSC is the basic part in an electric drive; this is synthesized with SPWM signals gating the IGBT full bridge, generating a three phase AC signal. The VSC is nested in a subsystem with a three phase measurement and an induction as load, the PWM signals are generated depending of the modulation index and frequency, the carrier frequency is 2 kHz. The Power dissipation waveform obtained uses a simulation time of 0.02s. As previously stated, the diagram block depicted in figure 14 is now realized in Simulink with the same parallel VSC with the current and voltage measurement block, figure 14 shows the connection. Figure 15 shows the reduction of inner power with the area under curve integration. The load is not affected because it is highly inductive.

6. Conclusion

The fuzzy logic control is a good solution in non-linear and complicated decision systems like those exposed here, in order to enable the multiple operation ranges and the changes in current of the VSC. The proposed fuzzy logic controller provides robust and reliable control of the DC Link. The design methodologies of the controller and simulation results are presented in this paper. The objective is make voltage zero whenever inverter switches change states. Considerable reduction of power in the proposed circuit of the parallel Voltage Source Converter.

References

- Shireen, W., Misir, D, Malki, H.; Arefeen, M.S (1996). "A soft switch scheme Telecommunications Energy Conference".
- H.Ying (1993), "The simplest Fuzzy Controllers using different methods are different nonlinear proportional-integral controllers with variable gains Automatica", Vol. 29, NO.6, pp: 1579-1589.
- Diaz, N., Barbosa, F., Trujillo, C. (2007), "Analysis and Design of a Nonlinear Fuzzy Controller Applied to a VSC to Control the Active and Reactive Power Flow", IEEE Proceedings, CERMA, September de Cuernavaca Mexico.
- D. M. Divan, et (1987), "Zero switching loss inverters for high power applications", IEEE-IAS Cod. Ret>, pp.5 17634.
- Ned Mohan et (1990). "Zero voltage switching PWM inverter for high frequency DC-AC power conversion", IEEE-IASconf.Rec., pp.1215-1221.
- E. H. Mamdani (1974), "Application of fuzzy algorithm for control of simple dynamic plant", Proc. IEEE, 121, pp.1585-1588.
- Salerno, H (2001). "A Fuzzy Speed Control for a Three-phase Induction Motor", Paper accepted for presentation at PPT IEEE Porto Power Tech.

Chamorro, H. R (2009), "Simulation and Hardware Verification of a PD Fuzzy Speed Controller for a Three Phase Induction Motor", 9th Electrical Power & Energy Conference EPEC.

V.Manoj born in the year 1988 is currently doing his Post Graduate course in Power systems and automation in Electrical and Electronics Engineering, department of GITAM Institute of Technology, GITAM University, Visakhapatnam, India, Bachelor degree in Electrical and Electronics Engineering from JNTU Kakinada, Andhra Pradesh, India, in 2010.

K.Manohar received his master degree in Power system control and automation from JNTU Hyderabad, in 2008, Bachelor degree in Electrical Engineering from JNTU Hyderabad, India, in 2005. He is currently working as an Assistant Professor of Electrical and Electronics Engineering department at GITAM Institute of Technology, GITAM University, Visakhapatnam, Andhra Pradesh, India. His research interest includes Power system protection HVDC transmission.

B.Durga Prasad received his master degree in Power system control and automation from Andhra University, in 2008, Bachelor degree in Electrical Engineering from JNTU Hyderabad, India, in 2004. He is currently working as an Assistant Professor of Electrical and Electronics Engineering department at GITAM Institute of Technology, GITAM University, Visakhapatnam, Andhra Pradesh, India.

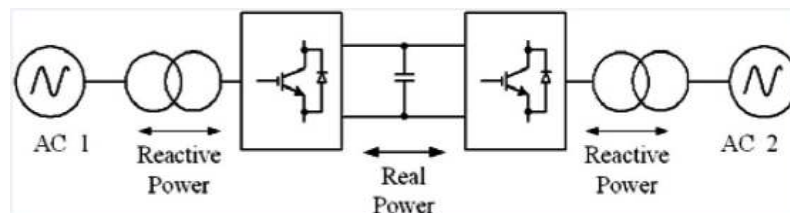

Figure 1. VSC-HVDC concept scheme

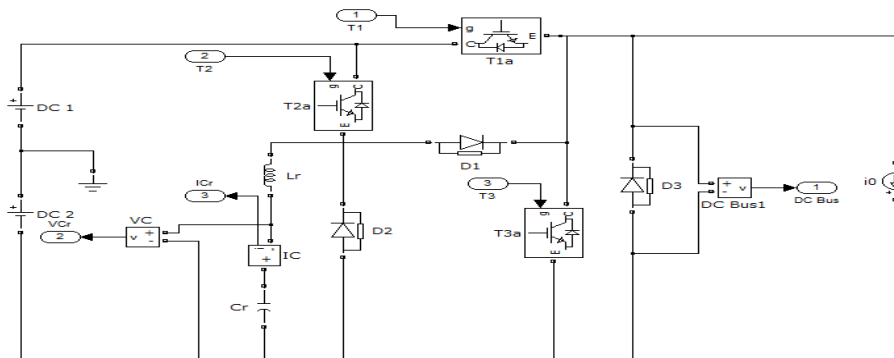

Figure 2. Soft Switching Scheme

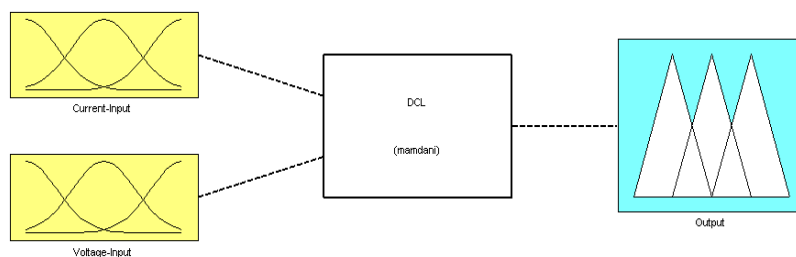

Figure 3. Fuzzy Inference System Editor

Figure 3 depicts that the Fuzzy Inference System Editor consists of two input variables i.e., Current, Voltage and one Output variable.

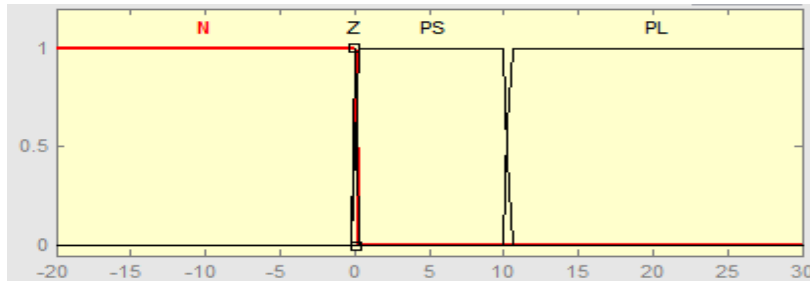

Figure 4. Membership Function characterizing the current input

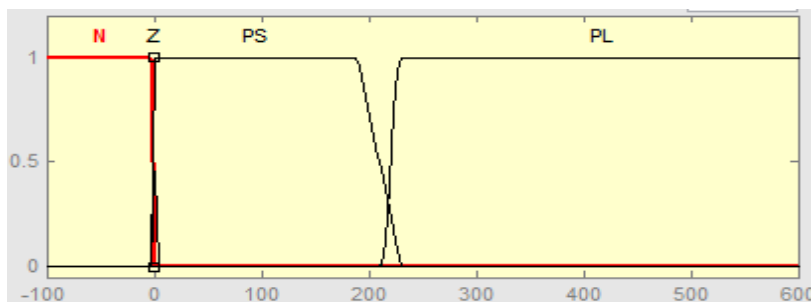

Figure 5. Membership Function characterizing the voltage input

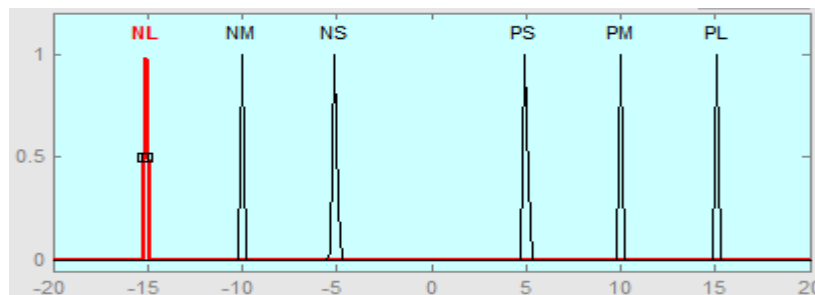

Figure 6. Output Membership Function

Here the Membership Functions characterizing the current, voltage inputs and output with linguistic variables. Current input ranges from [-20 30], Voltage input ranges from [-100 600] and Output ranges from [-20 20].

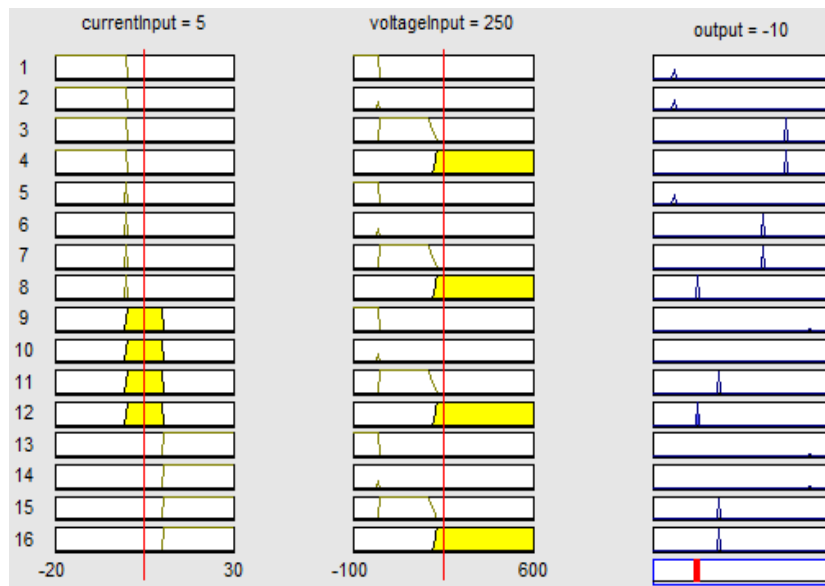

Figure 7. Rule view of input membership functions

The rule viewer displays the fuzzy inference process according to rule editor and fuzzy editor. The three small plots across the top of the figure represent the antecedent and consequent of the first rule.

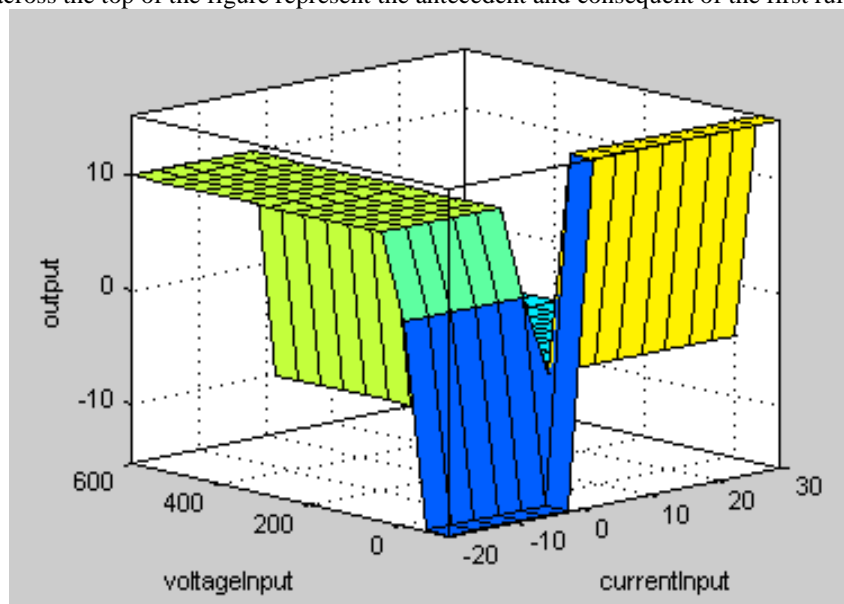

Figure 8. Surface view of input membership functions

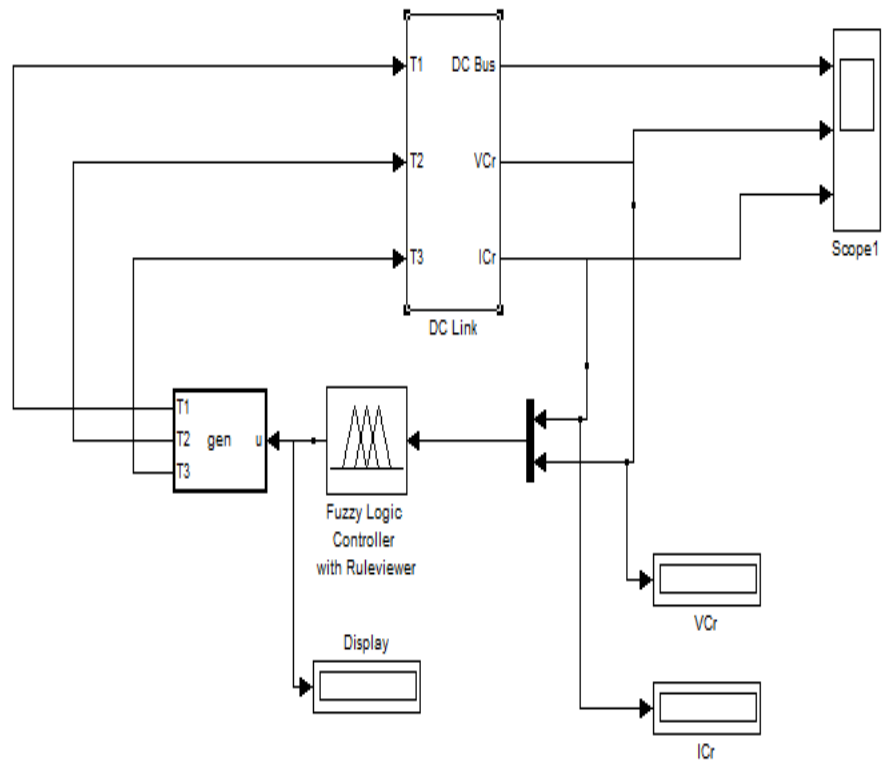

Figure 9. Fuzzy DC Link structure in simulink

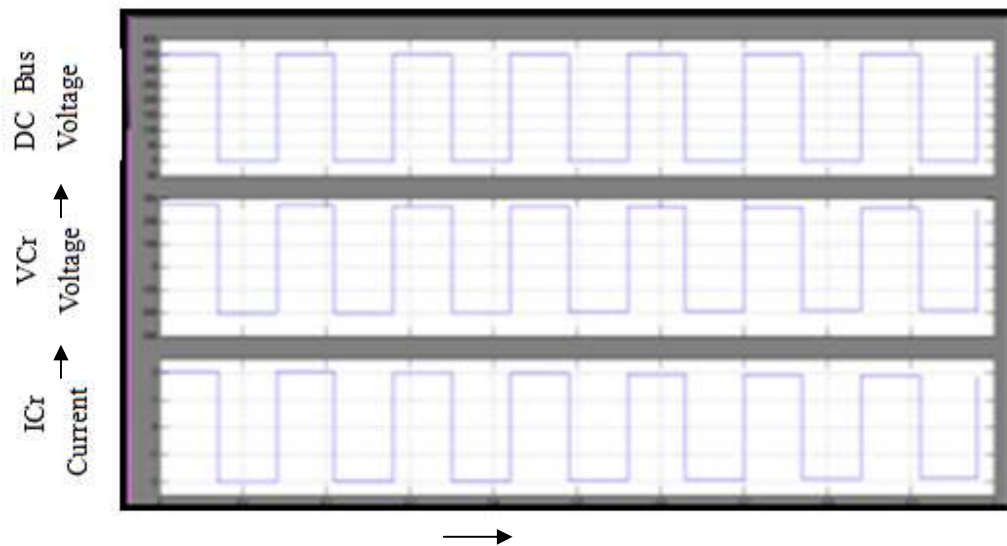

Figure 10. Waveforms Simu Time /itching Scheme

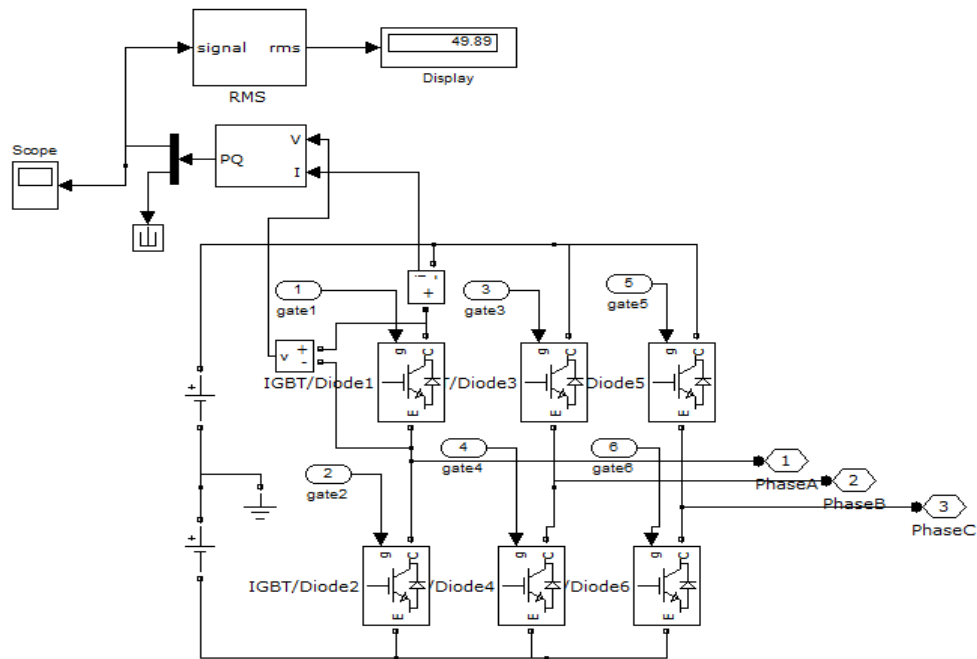

Figure 11. Voltage source inverter

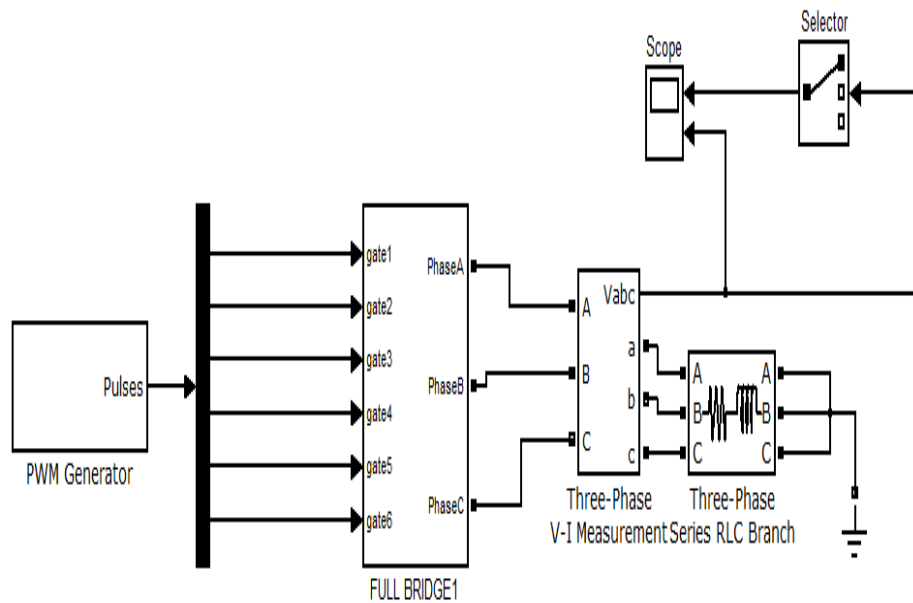

Figure 12. Without soft switching circuit

Figure 12 depicts that the VSC is nested in a subsystem with a three phase measurement and an induction as load, the PWM signals are generated depending of the modulation index and frequency, the carrier frequency is 2 kHz.

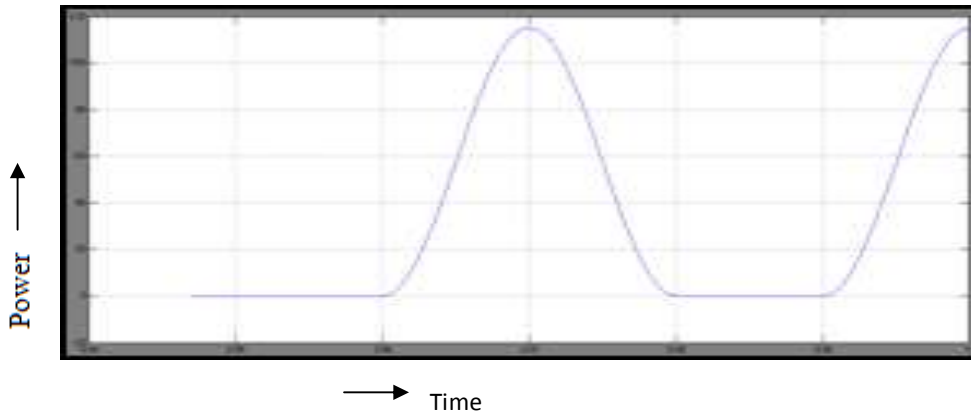

Figure 13. IGBT Power dissipation in a hard-switching circuit
 Figure 13 depicts that the power dissipated in the hard-switching circuit is 117 Watts.

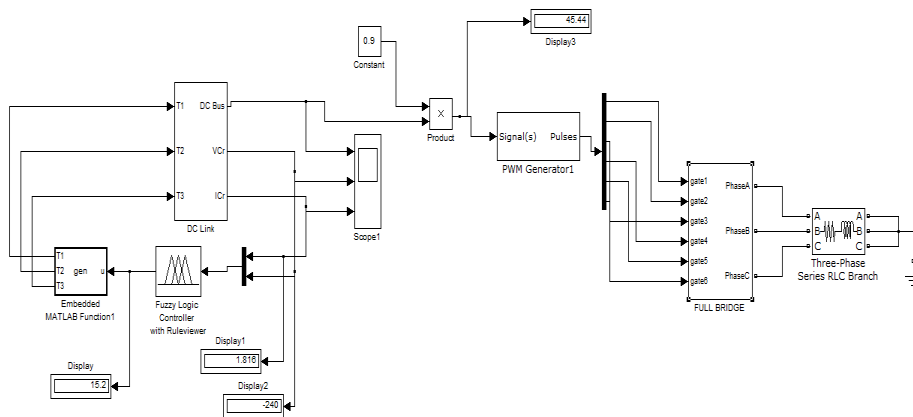

Figure 14. System with fuzzy DC link controller (Fuzzy DC link controller is added in parallel with inverter).

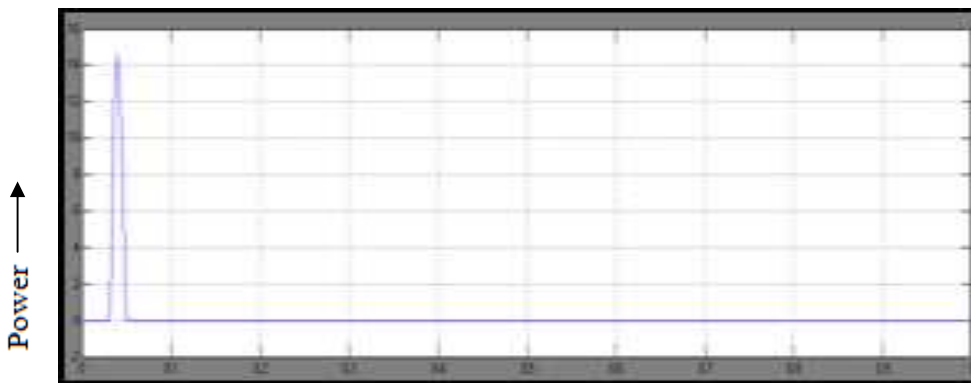

Figure 15. IGBT Power dissipation in a soft-switching circuit
 Figure 15 depicts that the power dissipated in the soft-switching circuit is 14 Watts and switching loss is less when compared to without fuzzy controller which has 117 Watts.

Table 1. Fuzzy rule base decision table

Vc/Ic	N	Z	PS	PL
N	NL	NL	PM	PM
Z	NL	PS	PS	NM
PS	PL	PL	NS	NM
PL	PL	PL	NS	NS

The decision table of control rule base determine what switch must turn off or on, due to the current and voltage changes. The above table consists of 16 rules.

The rules can be written as follows:

- 1.If Ic is N and Vc is N THEN OUTPUT is NL
- 2.If Ic is N and Vc is Z THEN OUTPUT is NL
- 3.If Ic is N and Vc is PS THEN OUTPUT is PL

This academic article was published by The International Institute for Science, Technology and Education (IISTE). The IISTE is a pioneer in the Open Access Publishing service based in the U.S. and Europe. The aim of the institute is Accelerating Global Knowledge Sharing.

More information about the publisher can be found in the IISTE's homepage:

<http://www.iiste.org>

The IISTE is currently hosting more than 30 peer-reviewed academic journals and collaborating with academic institutions around the world. **Prospective authors of IISTE journals can find the submission instruction on the following page:**

<http://www.iiste.org/Journals/>

The IISTE editorial team promises to review and publish all the qualified submissions in a fast manner. All the journals articles are available online to the readers all over the world without financial, legal, or technical barriers other than those inseparable from gaining access to the internet itself. Printed version of the journals is also available upon request of readers and authors.

IISTE Knowledge Sharing Partners

EBSCO, Index Copernicus, Ulrich's Periodicals Directory, JournalTOCS, PKP Open Archives Harvester, Bielefeld Academic Search Engine, Elektronische Zeitschriftenbibliothek EZB, Open J-Gate, OCLC WorldCat, Universe Digital Library, NewJour, Google Scholar

