

Design of Wireless Sensor Network for Drainage Monitoring System

Retno Tri Wahyuni^{1*} Yusmar Palapa Wijaya² Dini Nurmalasari³

Electronic Department, Politeknik Caltex Riau, Umban sari street No.1 Rumbai, Pekanbaru 28265, Indonesia^{1,2}

Informatics System, Politeknik Caltex Riau, Umban sari street No.1 Rumbai, Pekanbaru 28265, Indonesia³

* E-mail: retnotri@pcr.ac.id¹, yusmar@pcr.ac.id², dini@pcr.ac.id³

Abstract

Drainage is defined as the infrastructure for drying the land from the excess and unutilized water; rainwater and waste water. Drainage conditions should be monitored in order to maintain its proper function. In fact, not all areas have drainage monitoring team. It leads to irregular monitoring of the drainage condition. The irregular monitoring has contribution on the clogging of the drainage that imply to the siltation which trigger flooding in the neighbourhood. Manual monitoring is also inefficient. It needs a lot of dedicated persons who are only able to record limited report with low accuracy. These weaknesses lead to the slow handling for problems in drainage. This paper discuss about the design of drainage systems intended to monitor conditions at several points in drainage system using wireless sensor networks. Some sensor nodes are deployed at several determined points to be connected each other. The recorded data will be stored into a database that is visualized by Geographical Information System (GIS). The monitoring parameters are water levels in drainage, water discharge and rainfall conditions around the drainage area. This system is expected to monitor the drainage conditions real time continuously, and to store the data properly. The presenting data through GIS is expected to be a reference for determining drainage master plan in an area.

Keywords: Drainage, Node sensor, wireless sensor network

1. Introduction

Drainage is defined as the infrastructure for drying the land from the excess and unutilized water; rainwater and waste water (team 1997). The type of drainage channel can be natural channel or constructed channel. In an urban, drainage channels built to control the surface water due to rain, waste water, so it does not disturb the activities and the country's facilities and property in the community.

Drainage conditions should be monitored in order to maintain its proper function. In fact, not all areas have drainage monitoring team. It leads to irregular monitoring of the drainage condition. The irregular monitoring has contribution on the clogging of the drainage that imply to the siltation which trigger flooding in the neighbourhood. Manual monitoring is also inefficient. It needs a lot of dedicated persons who are only able to record limited report with low accuracy. These weaknesses lead to the slow handling for problems in drainage.

Wireless Sensor Network (WSN) is a monitoring technology which consists of node sensors that spread and coordinated use of a wireless network system. Each node has data processing (microcontroller, CPU or DSP chip), memory (program, data, flash memory), RF transceiver, power supply system (battery or solar cell), and involves one or more sensors and actuators (stankovic 2006). In (Wayne 1999), WSN systems have a higher level of efficiency than wire line network system in terms of cost, flexibility and reliability and is expected to replace the hybrid technology (wire line and wireless) in the coming years. WSN technology can be applied in many fields that require monitoring data regularly. An example is the environmental experts which monitor the habitat of a region, monitoring the dry fields of fire (fire bug), preventive maintenance on oil tankers using sensor network support, or observation of mountain environments that have the seismic parameters that can remotely monitor the level of activity of the volcano. Urban areas can also utilize this technology as in (Roberto 2009), WSN can monitor air pollution, strength building, flood hazards, the level of hilarity (noise) and the video feed, where everything can be observed through visualization of the data using the concept of Geographic Information System (GIS).

In an urban area, drainage has an important role in the prevention of flood danger. Much researcher have research about the drainage system is related to drainage design as found in the study (Leonardo 2013) (Dwiati 2011). While researches about management of drainage has not been much discussed. Some researchers who have done research on the management of drainage are among others (Adianta 2012). In these studies emphasize about the control simulation of sewerage system for monitoring sensors and instrumentation drainage conditions. While research related to the implementation of a wireless sensor network (WSN) in the management of the drainage system has not been done. This paper will discuss the design of drainage systems to monitor conditions at some point in drainage by wireless sensor networks. Some node sensors are deployed at some point will be communicated and will transmit the data about the condition of drainage to server. The parameters will be monitored are water levels in drainage, water discharge and rainfall conditions around the drainage area.

2. Method

Wireless sensor network is a network that communicates some sensor nodes that are implemented in some areas. Each sensor node consists of a sensor unit, a communication unit and a power unit. It is important in wireless sensor networks design is how to combine these units. Design of drainage monitoring system consist of several stages are:

a. Design of Sensor nodes

The important component on sensor nodes are sensors unit, processor, RTC (Real time Clock), SD cards, wireless communication unit, and supply units. Sensor has a function to sense physical quantities to be measured. RTC control the data transmission time. SD card for temporary data storage. Wireless communication unit for communicating sensor nodes. Supply units give a power for sensor nodes.

The processor is an important part that will affect to the performance and energy consumption. Some types of processors that can be used are: Microcontroller, Filed Programmable Gate Array (FPGA), IC (integrated circuit) with specific application. The type of sensor also affect to realibility of sensor nodes. The sensors must weatherproof and resistant to noise because the sensor will be placed outdoor. The wireless communication units can be used are: radio frequency (RF) communication or GSM (Global system for Mobile Communications).

b. Design of Communication units

In wireless sensor network, the type of network topology that can be used are star, ring, bus, tree, mesh and fully connected topology as shown in Figure 1. Network topology that used in this design is bus topology.

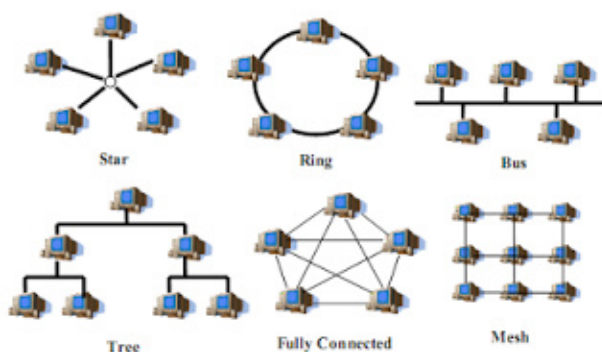

Figure 1. Types of Network Topology

Sensor nodes will be connected each other via wireless communication using radio frequency module. Communication between sensor nodes ended at gateway. From the gateway the data transmit to the server via GSM (Global System for Mobile Communication) connection. Block diagram of the communication between the sensor nodes can be seen in Figure 2.

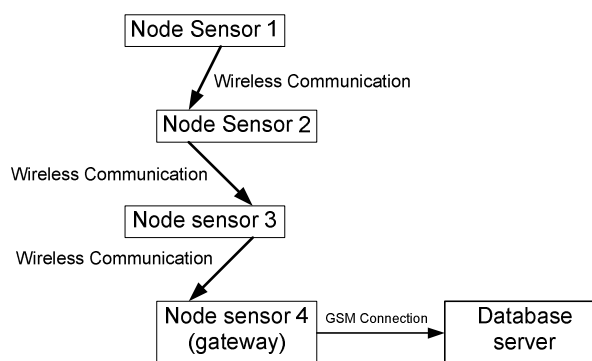

Figure 2. Block Diagram for Wireless Sensor Network

c. Design of Layout for sensor nodes

Layout of sensor nodes must consider to important thing such as: location sensor nodes must represent drainage conditions, distance between 2 sensor nodes must in communication range of radio frequency module that be used, connections between 2 sensor nodes must between the closest distance of sensor nodes because of minimizing delay and noise, location of gateway must have good access to GSM signal and the position of gateway in middle of sensor nodes.

d. Design of data base system

Data base is designed in order to facilitate the management of data (editing data), make it easy for searching data, give real time informations, user friendly and supporting to the decision making process.

3. Results and Discussion

It has been explained that wireless sensor network consist of sensor unit, communication units and supply unit. The working principle of wireless sensor networks can be described as the sensors collect data sensing that will be transmitted by the processor to the gate way. At the gateway, data will be processed and sent to the server. When the sensor devise report parameter exceeds the specified limit, the server will give the command to the controller to decrease or increase the performance of electrical equipment. This section will discuss about type of sensor that be used, processor, communication module, layout for sensor nodes, and general design for data base for drainage monitoring system.

3.1 Sensor Unit

Based on drainage monitoring guidelines, the monitoring parameters are rainfall, water level and water discharge. So the sensor that we need are rainfall sensor, water level sensor and velocity water flow sensor. There are several types of rainfall sensor include [graduated cylinders](#), weighing gauges, tipping bucket gauges, and simple buried pit collectors. Each type has its advantages and disadvantages for collecting rain data. The type that be used in this design is tipping bucket gauges. This sensor consist of a funnel, seesaw and container. A funnel collects the water and then the water flow to the container on seesaw. If the seesaw falls, then dumping the collected water and then sending signal. That signal will be count to determain value of rainfall. The tipping bucket sensor is not as accurate as standard rain guage, but it is quite appropriate for drainage monitoring system. The advantage of the tipping bucket sensor is easy to obtaine character of the rain.

Water level sensor is used to determine the water level and contributes to calculation of water discharge. If the water level increases while the rainfall and water discharge normal it means that occurs siltations in the channel. The type of level sensor that used is a piezoresistive sensor type of GTL500TM. This sensor has special structure and supplication. It has high accuracy. It is widely used in coastline monitoring, sewage treatment, water saving irrigation, water diversion project etc.

Water discharge is obtained by multiplying the velocity of water flow (V) by wet cross section area (A). Measurement velocity of water flow using current meter. Wet cross section area is calculated use hydraulic formula. There are three types of cross section channel drainage that is trapezoidal, rectangle, and circle. Trapezoid shape used for irrigation or drainage channels, because it has the shape of a natural channel, where the slope of the ridge to adjust the angle of the natural slope of the land used for the channel. Rectangle used for used for drainage channels through the narrow land. Circle is usually used at a crossroads (Chairil 2013). The

formula for calculate wet cross sectional area can be seen in Figure 3. The high variable ('y' at rectangle and trapezoid type, 'd' at circle type) obtained from water level sensor result.

$$Q = VxA \tag{1}$$

Q = water discharge (m³/s)

V = water flow (m/s)

A = wet cross section area (m²)

	Rectangle	Trapezoid	Circle
			
Area, A	by	$(b+xy)y$	$1/(\text{Ø} - \sin \text{Ø})D^2$

Figure 3. Formula for Calculate wet cross sectional area

3.2 Hard ware of Node Sensor and Gateway

Hardware on the node sensor includes sensors unit, signal conditioning, processor, RTC (Real time Clock), SD cards, RF (Radio Frequency) modules and supply units. Block diagram for the sensor nodes can be seen in Figure 4. The processor that used is microcontroller ATmega 128. The consideration use ATmega 128 is easy to use, less power or energy consumption, and efficient cost. The RF modul that used are X-Bee™. This module require minimal power and provide reliable delivery of data between remote devise. The modules operate within the ISM (Industrial, Scientific and medical) 2.4GHz frequency band.

Based on Figure 4, output of water level sensors, water discharge sensor and rainfall sensor conditioned as standard input signal for microcontroller. Output of signal conditioning will be input to the internal ADC (Analog to Digital Converter) of Microcontroller. RTC set the time of data collection, SD card will store data temporary, and then RF Module (X-Bee™) send the data to other sensor nodes. Supply unit can be either baterai or solar cell give the power to the sensor node.

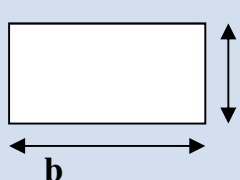
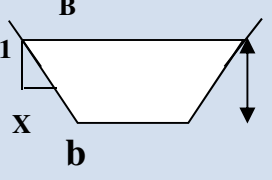
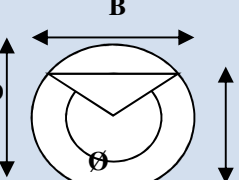
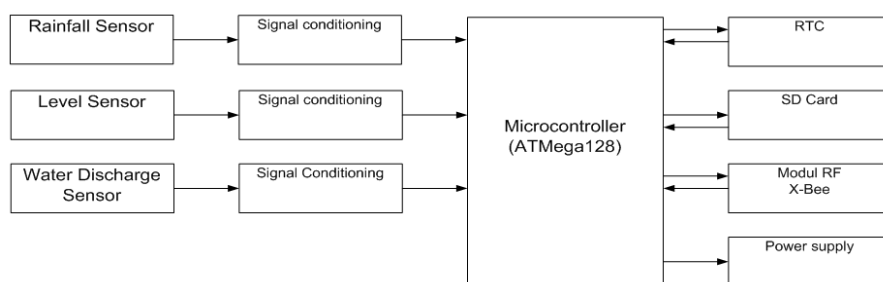

Figure 4. Block Diagram for Sensor Node

The gateway is sensor node that have additional functions to send data to the server. The communication mode that used in this design is GSM (Global System for Mobile Communication) connection. The component that we used are GSM modem. Block diagram of gateways can be seen in Figure 5.

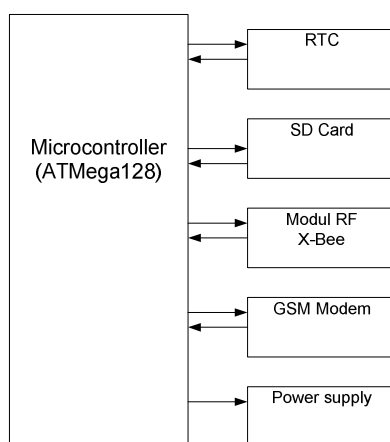

Figure 5. Block Diagram for Gateway

3.3 Layout for Sensor Nodes

It has been explained that location sensor nodes must represent drainage conditions. The example area for laying the sensor nodes can be seen in Figure 6. From the topography area we must defined catchment area (zone rainwater). There are shown 3 catchment areas. Furthermore, the drainage direction is defined as shown in figure. In the drainage system there are three channels, namely tertiary, secondary and primary channels. Tertiary channel drain rainwater from the catchment area to the secondary channel. Secondary channel drain rainwater from tertiary channel to primary channel, while the primary channel drain rainwater from the secondary channel to sewer.



Figure 6. Condition of Topography and Drainage Channels

Installation of water discharge sensors and level sensors will be installed at certain points in each type of the channel. While rainfall sensors will be placed around the tertiary channels in order to determine the volume of rain water in the region. The layout of node sensor can be seen in Figure 7.

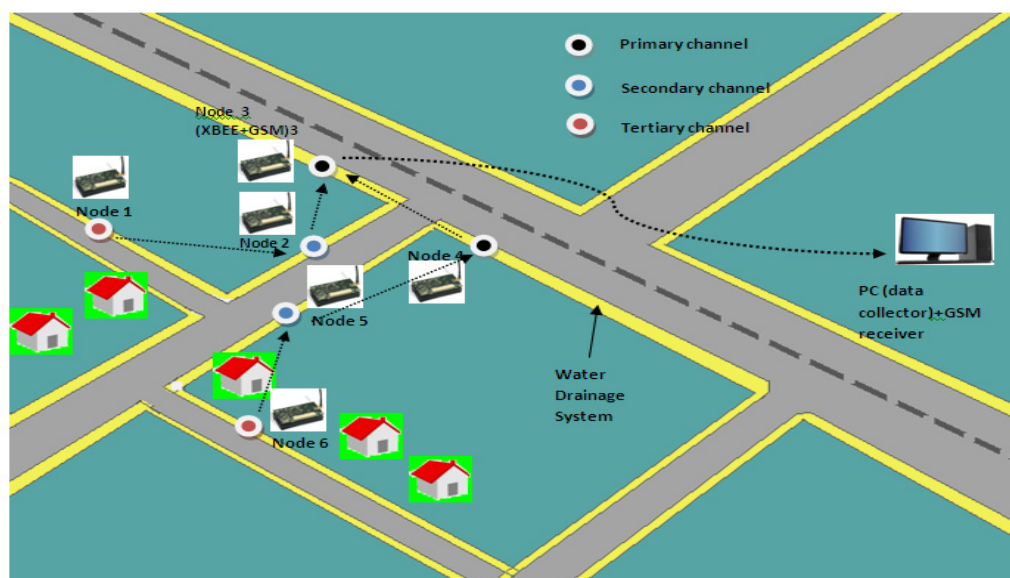

Figure 7. Layout for Node Sensor

In Figure 7, there are 6 node sensors where each adjacent node sensors will communicate with each other. While the node sensor number 3 also as gateway. Sensor nodes will transmit the data to the closest sensor node to be forwarded to the sensor nodes that also functions as a gateway. Furthermore, the gateway will send the data to the server. Data in the form of water level, water discharge and rainfall for each region will be sent to the server. The recorded data will be stored into a database that is visualized by Geographical Information System (GIS).

3.4 General Design of Data base System

Database in this research will be used to manage data for monitoring of drainage. One goal of this drainage data management systems is to identify drainage problems in each region. So the system facilitate the monitoring team for observing and recording the drainage conditions in each region. Activities to be undertaken in the management of this data include several stages, based on software development activity (SDLC - Software Development Life Cycle). The stages consist of :

1. Planning / Requirements

At this stage the activity is gathering information and data necessary to identify specification business rule and business process. In this stage, data will gathering using observations and interviews with users of the system.

2. Analysis and Design

The activity in this stage is to analyze all the data, information and business processes that are the result of the previous stage. The analysis is done by identifying objects or entities, attributes and relationships will be managed in the drainage system. Then conducted data modeling using entity relationship diagram design (ERD) to see the possibility of the implementation of the system. A good ERD can affect the easy of accessing and storing data in the database.

3. Implementation

At this stage of the modeling data that has been generated from the previous stage, will be transformation into the form of a table, and then implemented using specific DBMS (Database Management System) i.e SQL Server or Oracle Database. The stage in the development activities undertaken drainage database system can be seen in Figure 8.

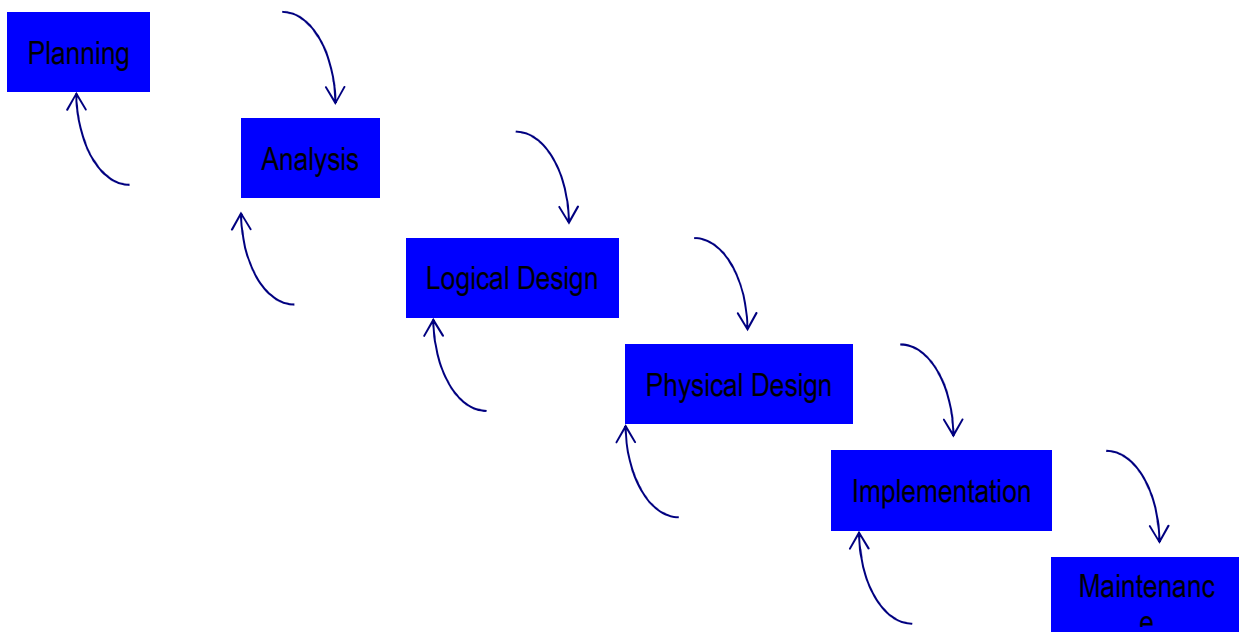

Figure 8. Data base Development Activity

This drainage system information will be displayed in the form of GIS (Geographical Information System). In particular, the GIS software consists of three main stages, namely the input, process and analysis. The data managed by the database drainage will be one input to the GIS. The stage in the GIS development activity can be seen in Figure 9.

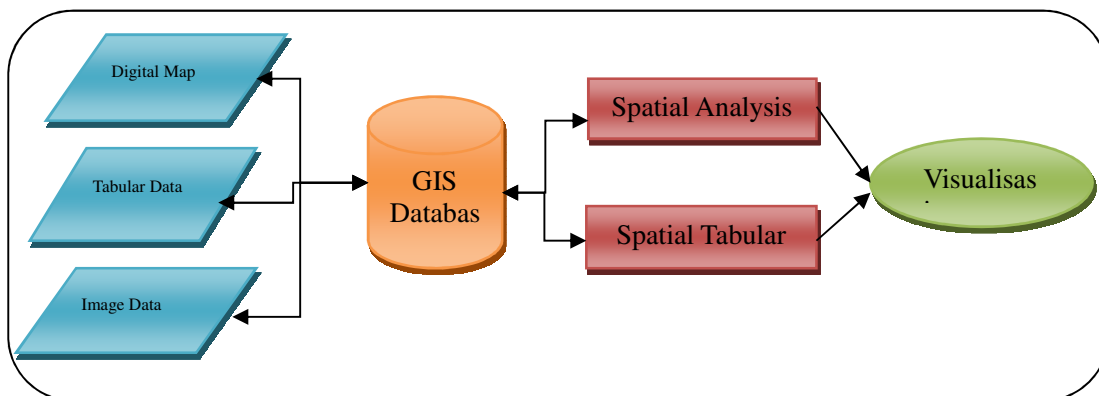

Figure 9. Development GIS Activity

Data about drainage system will managed in a database system (DBMS) is a kind of tabular data input in the development process of GIS. So generally, a description of each of these data are:

1. Digital Map : Data for GIS maps including the drainage system Pekanbaru city, administrative area map and a map of the road network in the city of Pekanbaru
2. Tabular Data : Example data in tabular data i.e rainfall intensity data, administrative boundaries, population density and the amount of data, geological data and topology of the region, rainfall data, water level and water discharge.
3. Data Image : is used to complementary data, such as photos of the building location, photo-gates, as well as other vital objects.

4. Conclusion

Wireless sensor network is a network that communicates some sensor nodes are implemented in some areas. Each sensor node consists of a sensor unit, a communication unit and a power unit. Design of drainage monitoring system based on wireless sensor network consist of several stages are: design of sensor node, design of communication unit, design of lay out sensor node, and design of data base system.

The important component on sensor nodes consist of sensors unit, processor, RTC (Real time Clock), SD cards, wireless communication unit, and supply units. In the drainage monitoring systems, the sensors are rainfall sensor, water level sensor, and water discharge sensor. Node sensors communicate with each other using the Radio Frequency module (XBee™). Communication between gateway and server use GSM module. The recorded data will be stored into a database that is visualized by Geographical Information System (GIS).

Some considerations in lay out of the sensor nodes are: location sensor nodes must represent drainage conditions, distance between 2 sensor nodes must in communication range of radio frequency module that be used, connections between 2 sensor nodes must between the closest distance of sensor nodes because of minimizing delay and noise, location of gateway must have good access to GSM signal and the position of gateway in middle of sensor nodes.

Suggested future works are builds, analyze and evaluate designs that have been created. The results of the analysis and evaluation will be input for building drainage systems monitoring more reliable.

Acknowledgements

Special thanks for our management campus Politeknik Caltex Riau for all support. Thanks to Indonesia Directorate Collage who fund this research through “Hibah Bersaing 2014” program.

References

- Stankovic, John A.(2006), “Wireless Sensor Network”, Department of Computer Science, University of Virginia.
- Wayne Manges., April 1999, “It's Time for Sensors to Go Wireless. Part 1: Technological Underpinnings.”, Sensors Magazine
- Roberto De Lottoa, Tullio Facchinettia, Paolo Gambiaa, Emanuele Goldoni, *Wireless Sensor Networks for urban applications: evaluation and practical considerations*.
- Leonardo Taawoeda, Alex Binilang, Fuad Halim, ”Perencanaan Sistem Drainase Kompleks Perkantoran Bupati Bolaang Mongondow”, Jurnal Sipil Statik Vol.1 No. 2, Januari 2013(95-104)
- Th.Dwiati, 2011, “Metode Perkiraan Laju Aliran Puncak (Debit Air) sebagai Dasar Analisis Sistem Drainase di Daerah Aliran Sungai Wilayah Semarang Berbantuan SIG”, Jurnal Teknologi Informasi DINAMIK Volume 16, No.2, Juli 2011 : 124-132
- Adhianta S.K, 2012, “Monitoring dan Pengendalian Sistem Drainase Berdasarkan Algoritma Fuzzy berbasis Mikrokontroler ATMEGA 8535”, Tugas akhir Jurusan Teknik Elektro Universitas Islam Indonesia Yogyakarta.
- C Nizar, 2013, “Pengertian Hidrolika” <http://www.ilmusipil.com/pengertian-hidrolika>. 1 April 2014.

The IISTE is a pioneer in the Open-Access hosting service and academic event management. The aim of the firm is Accelerating Global Knowledge Sharing.

More information about the firm can be found on the homepage:
<http://www.iiste.org>

CALL FOR JOURNAL PAPERS

There are more than 30 peer-reviewed academic journals hosted under the hosting platform.

Prospective authors of journals can find the submission instruction on the following page: <http://www.iiste.org/journals/> All the journals articles are available online to the readers all over the world without financial, legal, or technical barriers other than those inseparable from gaining access to the internet itself. Paper version of the journals is also available upon request of readers and authors.

MORE RESOURCES

Book publication information: <http://www.iiste.org/book/>

Recent conferences: <http://www.iiste.org/conference/>

IISTE Knowledge Sharing Partners

EBSCO, Index Copernicus, Ulrich's Periodicals Directory, JournalTOCS, PKP Open Archives Harvester, Bielefeld Academic Search Engine, Elektronische Zeitschriftenbibliothek EZB, Open J-Gate, OCLC WorldCat, Universe Digital Library, NewJour, Google Scholar

