

# Voltage Stability Improvement Using the 21st Century Power Transformer

Charles Mwaniki<sup>1,2</sup> Nicodemus Abungu<sup>1</sup> Cyrus Wekesa<sup>1</sup>

1. Department of Electrical & Electronic Engineering, University of Nairobi, P.O. Box 30197-00100 Nairobi, Kenya
2. Department of Electrical & Electronic Engineering, Thika Technical Training Institute, P.O. Box 91-01000 Thika, Kenya

\* E-mail of the corresponding author: [mwanikicharles2005@yahoo.com](mailto:mwanikicharles2005@yahoo.com)

## Abstract

The 21st Century Power Transformer is produced by combining modern high voltage cross-linked polyethylene (XLPE) cable technology with conventional transformer. The technique of solid insulation is adopted in the new dry transformer so that the pollution from leakage of insulating oil can be avoided, and so XLPE cable-winding transformer is very suitable in environment sensitive places such as populous cities, hydropower stations, and underground caver and so on. This paper is meant to show that the marriage of the well-proven high voltage power cable technology with transformer technology sets a new standard in improving power system voltage stability.

**Keywords:** voltage stability, Voltage collapse, Dryformer, Transformer parameters, Load flow

## 1. Introduction

The research on voltage instability and collapse concerns disturbances in a power system network where the voltage magnitude becomes uncontrollable and collapses. The voltage decline is often gradual in the beginning of the collapse and difficult to detect. A sudden increase in the voltage decline often marks the end of the collapse course. During the last twenty years there have been one or several large voltage collapses almost every year somewhere in the world. The reason is the increased number of interconnections and a higher degree of utilization of the power system. Also load characteristics have changed. Two examples are the increased use of air conditioners and electrical heating appliances which may endanger system stability radically. It is believed by many professionals that the power system will be used with a smaller margin to voltage collapse in the future. The reasons are twofold: the transfer capacity of an existing transmission grid needs to be increased without major investments, and Environmental and political constraints limit the expansion of transmission network and generation near load centers, which has a negative influence on power system voltage stability. Voltage stability is therefore believed to be of greater concern in the future.

### 1.1 Power Transformer of the 21st Century

In 1997, a new type of dry power transformer, Dryformer, was launched. Dryformer is a new technological advance of dry power transformer, which is constructed from XLPE insulated high voltage cables as its winding, and is designed to provide a direct link between ultimate customers and transmission systems in one step. It contains neither oil nor SF<sub>6</sub> gas. Essentially, the new concept is based both on existing transformer technology and existing high voltage technology. Cooling of the unit is by forced air circulation. The new type of XLPE cable-winding transformer, developed based on the experience of HV generator manufacture, is delivered by ABB Company, the brand name of which is Dryformer. Prototype of XLPE cable winding transformer was trial-manufactured successfully in 1997. Life cycle assessment has shown that environmental impact is reduced as oil is not used and losses can

be reduced. This new oil free power transformer can be placed in areas of high population density where the demands for fire and explosion safety are high and where the environment is to be protected. The use of XLPE insulated high voltage cables as its winding will alter the power transformer parameters mainly due to the capacitive behavior of these cables. The total Insulation resistance between the conductor and the lead sheath is

$$R = \frac{\rho}{2\pi l} \ln \frac{R}{r} \quad \text{ohms} \quad (1)$$

The total capacitance between the conductor and the lead sheath is

$$C = \frac{2\pi \epsilon_0 \epsilon_r l}{\ln \frac{R}{r}} \quad \text{F/m} \quad (2)$$

## 2. Methodology

In voltage collapse, the decline in voltage magnitude is often gradual in the beginning and difficult to detect. A sudden increase in the voltage decline often marks the end of the collapse course. It is not easy to distinguish this phenomenon from transient stability where voltages also can decrease in a manner similar to voltage collapse. Only careful post-disturbance analysis may in those cases reveal the actual cause. The problem of voltage collapse is a dynamic phenomenon and transient stability simulation may be used. However, such simulations do not readily provide sensitivity information or the degree of stability. The problem regularly requires inspection of a wide range of system conditions and a large number of contingencies. For such application, the steady state analysis approach is much more suitable and can provide much insight into the voltage and reactive power loads problem. Many techniques have been proposed in the literature for evaluating and predicting voltage stability using steady state analysis methods. The P-V curves, active power-voltage curve, are the most widely used method of determining the proximity to voltage instability. They are used to determine the MW distance from the operating point to critical voltage. In this study, a 5-bus, high voltage (220kV) a.c network shown in figure1 was used. The steps followed in this study are shown below:

- I. Typical values of a given transformer parameter of transformer model shown in figure 2 were picked and for each value, the load demand at the transformer secondary side was increased gradually from zero in equal steps of 10MW. At each of the load demand, load flow study was carried and the results tabulated. The load flow study was carried out through simulation using PowerworldTM simulation software, version 15.
- II. A different parameter was picked and step 1 above was repeated.
- III. From the load flow results obtained in step 1, P-V curves of various values for all the parameters were then plotted.

## 3. Observations

The following observations were made on various transformer parameters

### 3.1 Series Resistance

In figure 3, the values of Pmax. for series resistance of 0.015 p.u, 0.030 p.u and 0.045 p.u were 188 MW, 178 MW and 167 MW respectively. This shows that when the transformer series resistance was doubled, the distance (in MW) from the operating point to the critical point was reduced by an average of 10.5 units for all the buses. At the candidate bus, the rate of voltage drop with increase in load was highest with higher values of series resistance. However, the rate of voltage drop with increase in load was independent of series resistance in the neighboring buses. The voltage drop margin prior to voltage collapse was highest in load bus as compared to the neighboring buses. However this voltage

drop margin was independent of transformer series resistance.

### *3.2 Flux Leakage Reactance*

From figures 4, the values of  $P_{max}$  for flux leakage reactance of 0.08 p.u, 0.16 p.u and 0.24 p.u were 188 MW, 131 MW and 103 MW respectively. This shows that when the transformer series resistance was doubled, the distance (in MW) from the operating point to the critical point was reduced by an average of 42.5 units for all the buses. At the candidate bus, the rate of voltage drop with increase in load was highest with higher values of flux leakage reactance. However, the rate of voltage drop with increase in load was independent of flux leakage reactance in the neighbouring buses. The voltage drop margin prior to voltage collapse was 0.4 p.u, 0.16 p.u, and 0.10 p.u in candidate bus (load bus), bus 4 and bus 3 respectively. This shows that the voltage drop margin prior to voltage collapse was highest in load bus as compared to the neighbouring buses. This voltage drop margin was independent of transformer flux leakage reactance at the candidate bus, but reduced with higher values of flux leakage reactance in the neighbouring buses.

### *3.3 Magnetizing Conductance*

From figures 5, the values of  $P_{max}$  for transformer magnetizing conductance of 0.6 p.u, 1.2 p.u and 1.8 p.u were 185 MW, 179 MW and 174 MW respectively. This shows that when the transformer magnetizing conductance was doubled, the distance (in MW) from the operating point to the critical point was reduced by an average of 5.5 units for all the buses. The rate of voltage drop with increase in load was highest with higher values of magnetizing conductance in all the candidate and the neighbouring buses. The voltage drop margin prior to voltage collapse was 0.42 p.u, 0.25 p.u, and 0.15 p.u in candidate bus (load bus), bus 4 and bus 3 respectively. This shows that the voltage drop margin prior to voltage collapse was highest in load bus as compared to the neighbouring buses. This voltage drop margin was independent of transformer magnetizing conductance at the candidate bus and in the neighbouring buses.

### *3.4 Magnetizing Susceptance*

From figure 6, the values of  $P_{max}$  for transformer magnetizing susceptance of 0.4 p.u, 0.8 p.u and 1.2p.u were 185 MW, 169 MW and 157 MW respectively. This shows that when the transformer magnetizing susceptance was doubled, the distance (in MW) from the operating point to the critical point was reduced by an average of 14 units for all the buses. The rate of voltage drop with increase in load was independent of magnetizing susceptance in the candidate and the neighbouring buses. The voltage drop margin prior to voltage collapse was 0.4 p.u, 0.2 p.u, and 0.05 p.u in candidate bus (load bus), bus 4 and bus 3 respectively. This shows that the voltage drop margin prior to voltage collapse was highest in load bus as compared to the neighbouring buses. This voltage drop margin was independent of transformer magnetizing conductance at the candidate bus and in the neighbouring buses.

### *3.5 Shunt Conductance*

From figure 7, the values of  $P_{max}$  for transformer shunt conductance of 0.4 p.u, 0.8 p.u and 1.2p.u were 164 MW, 159 MW and 149 MW respectively. This shows that when the transformer shunt conductance was doubled, the distance (in MW) from the operating point to the critical point was reduced by an average of 7.5 units for all the buses. The rate of voltage drop with increase in load was independent of shunt conductance in the candidate and the neighbouring buses. The range of voltage drop prior to voltage collapse was 0.46 p.u, 0.23 p.u, and 0.14 p.u in candidate bus (load bus), bus 4 and bus 3 respectively. This shows that the range of voltage drop prior to voltage collapse was

highest in load bus as compared to the neighbouring buses. This voltage drop margin was independent of transformer shunt conductance at the candidate bus and in the neighboring buses.

### 3.6 Magnetizing Conductance

From figure 8, the values of  $P_{max}$  on the candidate bus for transformer magnetizing susceptance of 0.2 p.u, 0.4 p.u and 0.8 p.u were 150 MW, 158 MW and 164 MW respectively. This shows that when the transformer shunt susceptance was doubled, the distance (in MW) from the operating point to the critical point was increased by an average of 8 units for all the buses. The rate of voltage drop with increase in load was independent of transformer shunt susceptance in the candidate and the neighboring buses. The range of voltage drop prior to voltage collapse was 0.45 p.u, 0.2 p.u, and 0.05 p.u in candidate bus (load bus), bus 4 and bus 3 respectively. This shows that the voltage drop margin prior to voltage collapse was highest in load bus as compared to the neighboring buses. This voltage drop margin was independent of transformer magnetizing conductance at the candidate bus and in the neighboring buses.

## 4. Conclusion

Higher values of transformer series resistance, flux leakage reactance, magnetizing conductance, magnetizing susceptance and shunt conductance brings the system operating point closer to the voltage collapse point, making the system more vulnerable to voltage collapse. The order of severity of these parameters on voltage collapse starting with the most severe to the least severe is flux leakage reactance, magnetizing susceptance, series resistance, shunt conductance and magnetizing conductance. Higher values of transformer shunt susceptance drives the system operating point far away from the voltage collapse point thus reducing likelihood of voltage collapse. Cross-linked polyethylene (XLPE) cable-winding transformer exhibit higher shunt susceptance due to the capacitive nature of these cable winding. Therefore power system voltage stability can be improved by replacing the traditional rectangular conductor-winding transformer with the Cross-linked polyethylene (XLPE) cable-winding transformer.

## References

- Byung Ha.L and Kwang Y. L (1991). Study On Voltage Collapse Mechanism In Electric Power Systems, *IEEE Transactions on Power Systems*, **Vol. 6**, No. 3,
- Forsmark S, Anderson T, Jaksts A. (1999). The Next Generation of Power Transformers, *International Conference on Transmission & Distribution*, Beijing, China, pp.1-7,
- Gao B, Morison G, and Kundur P,(1992). Voltage Stability Evaluation Using Modal Analysis, *IEEE Transaction on Power Systems*, **Vol. 7**, No. 4, pp. 1423-1543,
- Jaksts A, Forsmark S and Leijon M (1999). Power transformers for the 21 'st century, *IEEE Power Tech '99 Conference*, Budapest, Hungary,
- Kwanti H G, Pasrija A K, and Bahar L Y.(1986). Static Bifurcations in Electric Power Networks: Loss of Steady-State Stability and Voltage Collapse. *IEEE Transaction on Circuits and Systems*, **Vol. 33**, pp. 981-991.
- Leijon M, and Andersson T.(1999). High and dry-dryformer, an innovative high-voltage transformer design that eliminates the need for oil, promises a host of performance and environmental benefits. *IEE Rev 2000:9-14. International Conference on Transmission & Distribution*, Beijing, China, pp.1-7,
- Machowski J, Bialek J. Bumb J. R. (1997), *Power System Dynamics and stability* , John Wiley and Sons,
- Metwally I.A, Radwan R M and Abou-Elyazied A M.(2008). Powerformers: a breakthrough of high-voltage power generators, *IEEE Potentials*, **Vol. 27**, no. 3, pp. 37-44,
- Taylor C.W.(1994). *Power System Voltage Stability*. McGraw- Hill ,New York.

Wadhwa C L.(2009). *Electrical Power Systems* (5th Edition), pp 225-246, New Age Publishers.

International

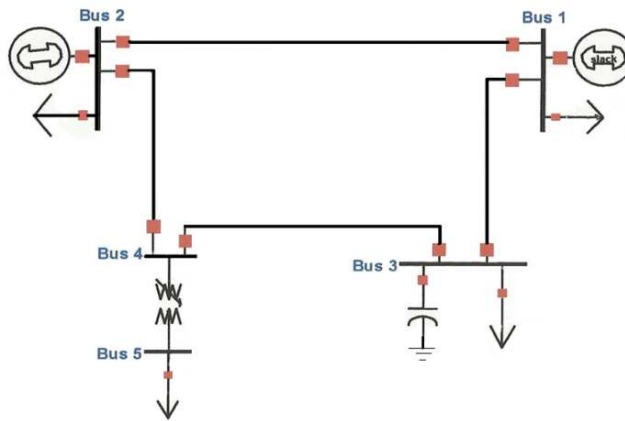

Figure 1. High Voltage ac Network

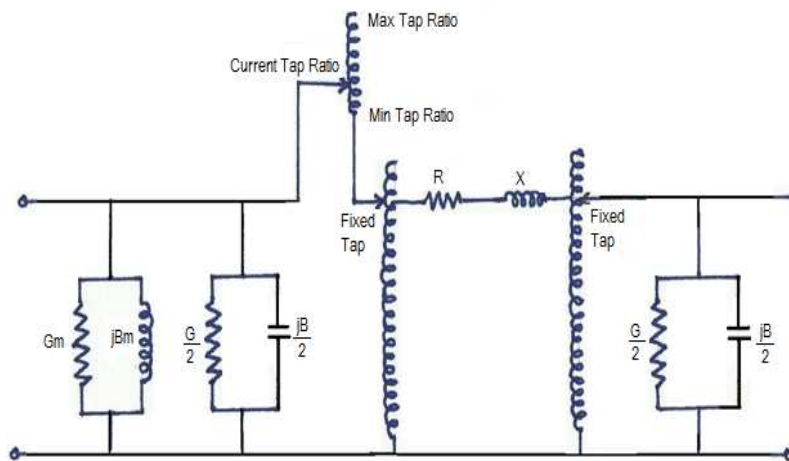

Figure 2 Transformer model. (courtesy of Powerworld corporation)

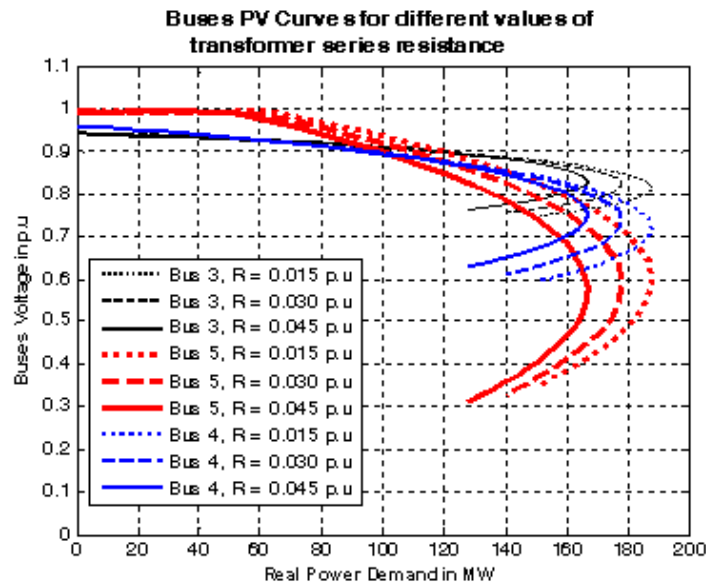

Figure 3. Buses PV curves for transformer series resistance

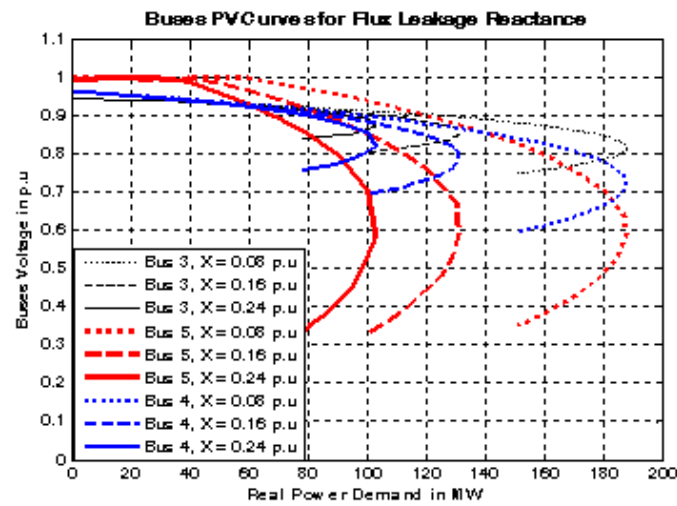

Figure 4. Buses PV curves for transformer leakage reactance

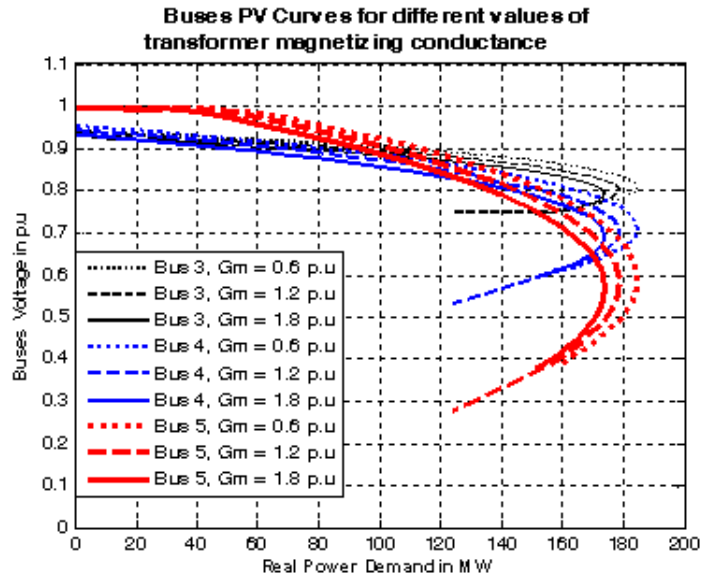

Figure 5. Buses PV curves for transformer magnetizing conductance

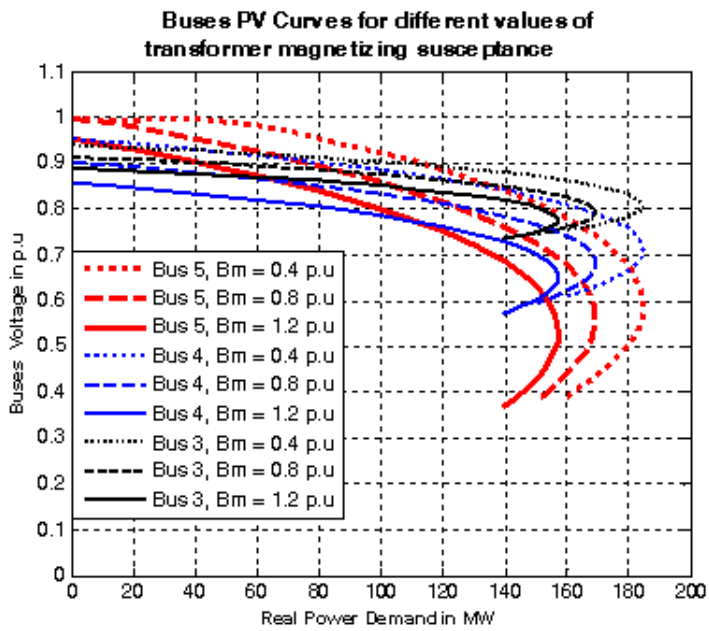

Figure 6. Buses PV curves for transformer magnetizing susceptance

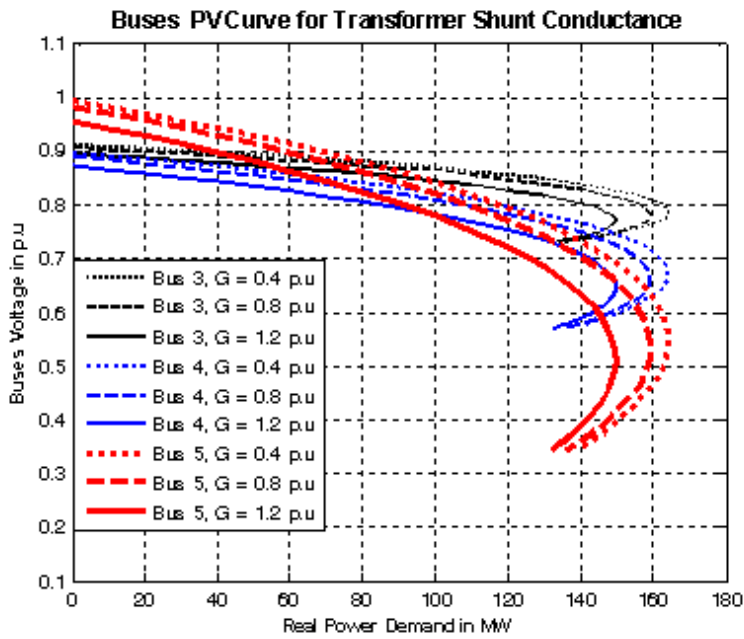

Figure 7. Buses PV curves for transformer shunt conductance.

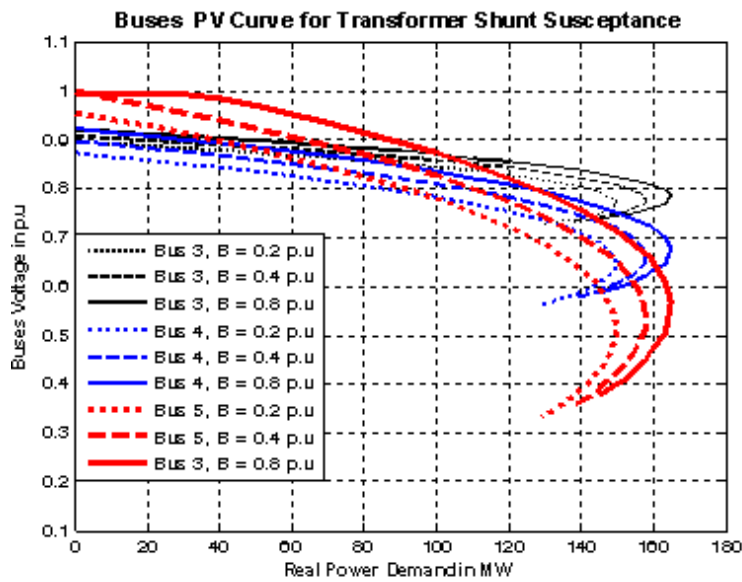

Figure 8. Buses PV curves for transformer shunt susceptance.



This academic article was published by The International Institute for Science, Technology and Education (IISTE). The IISTE is a pioneer in the Open Access Publishing service based in the U.S. and Europe. The aim of the institute is Accelerating Global Knowledge Sharing.

More information about the publisher can be found in the IISTE's homepage:

<http://www.iiste.org>

The IISTE is currently hosting more than 30 peer-reviewed academic journals and collaborating with academic institutions around the world. **Prospective authors of IISTE journals can find the submission instruction on the following page:**

<http://www.iiste.org/Journals/>

The IISTE editorial team promises to review and publish all the qualified submissions in a fast manner. All the journals articles are available online to the readers all over the world without financial, legal, or technical barriers other than those inseparable from gaining access to the internet itself. Printed version of the journals is also available upon request of readers and authors.

### **IISTE Knowledge Sharing Partners**

EBSCO, Index Copernicus, Ulrich's Periodicals Directory, JournalTOCS, PKP Open Archives Harvester, Bielefeld Academic Search Engine, Elektronische Zeitschriftenbibliothek EZB, Open J-Gate, OCLC WorldCat, Universe Digital Library, NewJour, Google Scholar

