

Optimum Number of Grounded Shield Wires underneath Extra High Voltage Direct Current Transmission Lines

Mohamed Mahmoud Samy (Corresponding author)

Electrical Engineering Department, Faculty of Industrial Education, Beni-Suef University, Beni-Suef, Egypt

Email: Mohamed_samy227@yahoo.com

Abstract

This paper is aimed at reducing the electric fields underneath extra high voltage direct current transmission lines using grounded shield wires. Two extra high voltage direct current transmission lines are modeled and analyzed. One line is homopolar and the other is bipolar, both are operating at 400 kV. The electric field calculated at the ground surface for the two transmission lines with and without grounded shield wires. In addition, the right-of-way limits for those transmission lines according to the maximum allowable electric field strength are calculated. The charge simulation method is used for calculating electric fields underneath the lines with and without grounded shield wires. A soft computer technique namely genetic algorithm was used also to determine the best location and number of grounded shield wires. The genetic algorithm was applied to a 400kV monopolar dc transmission; the best location of grounded shield wires is at 15m height above ground level for an optimum number of five grounded shield wires at spacing of 6m between them.

Keywords: Charge Simulation Method, Electric Field Calculation, Electric Field Reduction, Shield Wires, Direct Current Transmission Lines, Health Effects, Right of Way.

1. Introduction

In recent years, extra high voltage direct current (EHVDC) transmission lines became widely used for transmission of electrical energy because it has many advantages compared with EHV ac transmissions (1). Consequently, the possible effects of electric fields underneath EHVDC lines received an increasing interest in research studies, e.g. electric field induction and short circuit currents through conducting objects (e.g. parallel metallic fences and large vehicles), the electric field environmental impact on people and electric field interaction with human beings near power lines (2).

Consequently, a precise calculation of the electric field underneath overhead transmission lines became a very important task in transmission line design. The electric and magnetic field effect of operating transmission lines is an important issue that the electric utility engineer is most often required to respond to regarding the potential hazards due to the public exposure to these fields. The effect of long term or chronic exposure to electric fields is currently under study in several countries.

Several studies have reported that children living near high voltage transmission and distribution lines had a higher cancer and leukemia incidence than other children (3) did. However, limited studies have been reported regarding adults who live near high voltage transmission and distribution lines. Higher cancer incidence was observed than other adults. In addition, various lines of research have suggested that exposure to electromagnetic fields could lead to DNA damages in cells under certain conditions (4). Effects depend on factors such as the mode exposure, the type of cell and intensity and duration of exposure.

Overhead transmission lines require strips of land to be designed as right of way (ROW). These ROWs can also support other uses besides the transmission line. Increasing the amount of power transmitted requires higher voltages, therefore the transmission corridors are increased, and in turn, the competition for land and ROW increased.

As voltages reach the HV and EHV levels, wider ROW than that required by normal design codes may be requested by regulatory agencies. This decreases the multiple use possibilities of any ROW and further creates pressure to minimize the amount of land set aside for a high voltage transmission line.

The reduction of the electric field at ground level is the most direct objective of efforts to minimize the field effects of HVDC lines (11). In fact, most electric field effects occur close to ground level and are function of the magnitude of the unperturbed electric field at one meter above ground.

Some state regulatory staffs are considering control of electric field effects by controlling the maximum allowable electric field at the edge of the ROW.

It has been recommended before to adopt electric field strength in the $0.5 - 1 \text{ kVm}^{-1}$ range at edge of the ROW electric field strength standard in the $0.5 - 1 \text{ kVm}^{-1}$ ranges for dc transmission lines. Some regulatory staffs recommend a 1.5 kVm^{-1} as a maximum allowable electric field at the edge of ROW (8).

For these above reasons, electric field must be reduced to overcome its harmful effects on the people living or work nearby the transmission lines. One of the approaches is to use grounded shield wires underneath the line conductors (5-11). This is the main objective of the present paper.

For a simple physical system, it is usually possible to find an analytical solution. However, in many problems the physical systems are so complex that it is extremely difficult, if not impossible, to find analytical solutions. Hence, in such cases numerical methods employed for electric field calculations. The existing numerical methods include the Finite Difference Method (FDM), the Finite Element Method (FEM), the charge simulation Method (CSM), the Surface Charge Simulation Method (SCSM). The Surface Charge Simulation Method (SCSM) often called the Integral Equation Method (IEM). CSM has many advantages when compared with the other numerical methods for calculating electric fields. Therefore, the charge simulation method is used in this paper for calculating electric fields underneath homopolar and bipolar EHV transmission lines with and without grounded shield wires.

2. Calculation method

The idea of charge simulation method (CSM) is very simple (12, 13). For the calculation of electric fields, the distributed charges on the surface of the electrode are replaced by N number of fictitious charges placed inside the electrode at a radius R_f as shown in Fig. 1. In order to determine the magnitudes of the fictitious charges, some boundary points are selected on the surface of electrode. The number of boundary points is selected equal to the number of fictitious charges. Then it is required that at any one of these boundary points the potential resulting from superposition of effects all the fictitious charges is equal to the known electrode potential. Let, Q_j is the j^{th} fictitious charge and V is the known potential of the electrode. Then according to the superposition principle,

$$V = \sum_{j=1}^n P_{ij} Q_j \quad (1)$$

Where P_{ij} is the potential coefficient, which can be evaluated analytically for different types of fictitious charges. When Eq. (1) is applied to N boundary points, it leads to the following system of N linear equations for N unknown fictitious charges, then

$$[P]_{N \times N} [Q]_N = [V]_N \quad (2)$$

Where $[P]$ = potential coefficient matrix, $[Q]$ = column vector of known potential of contour points.

Equation (2) solved for the unknown fictitious charges. As soon as the required charge system is determined, the potential and the field intensity at any point, outside the electrodes can be calculated. While the potential is found by Eq. (1), the electric stress components are calculated by superposition of all the stress vector components.

For a Cartesian coordinate system, the x , y coordinate E_x and E_y would then be for a number of N charges.

$$E_x = \sum_{j=1}^N \frac{\partial p_{ij}}{\partial x} Q_j = \sum_{j=1}^N (f_x)_{ij} Q_j \quad (3)$$

$$E_y = \sum_{j=1}^N \frac{\partial p_{ij}}{\partial y} Q_j = \sum_{j=1}^N (f_y)_{ij} Q_j \quad (4)$$

Where $(f_x)_{ij}$, $(f_y)_{ij}$ are "field intensity coefficients" in the x and y direction.

3. Using GA

Genetic algorithms as explained in chapter three aim at finding the global optimum solution by using direct random search in any kind of system complexity. Mathematical properties such as differentiability, convexity, and linearity are of no concern for those algorithms. This is the biggest advantage of this searching over traditional optimization techniques.

The problem of minimizing the electric field at the surface of ground level by means of grounded shield wires has received considerable attention as previously explained in details in the above sections of this chapter.

A new approach is introduced in this section to reduce the electric field at ground level; this approach is based on genetic algorithm. The genetic algorithm is used to determine the best locations and number of grounded shield wires underneath EHVDC transmission line.

The search of any genetic algorithm starts with a random generation of a population of strings, each generation consists of a group of population and each population consists of a group of strings. The number of strings in a

population must be even, each string is divided into a number of substrings equals to the number of the problem variables and each substring consists of a number of genes to represent one of the variables in a certain coding system. Floating point, decimal point, and binary coding systems could be used. In this study, the binary coding system is used. Evaluate each string in the population by using the fitness function which maps the problem objective function.

The objective function will use in genetic algorithm to optimum, can write as

$$\text{Objective function} = \text{minimize (electric field)}$$

The first step of the main program of genetic algorithm is to set the ranges of the systems variables. The GA begins its operation by initializing the input population which consists of a number of citizens. Each citizen in this population is a choice of the number of grounded shield wires and their location (spacing between them and height from ground level) in other words, each citizen can be considered as a separate solution of the problem suggested by the GA. Usually, this initial population is chosen randomly i.e. each element in this population is selected within its range according to a uniform distributed probability function.

The next step is to calculate the electric field associated with each citizen alone. The electric field estimation is done using a subroutine different from the GA main program. It is dependent on the problem which GA is interested in. This subroutine is considered, from GA main program's point of as just an objective function that supplies GA with the fitness values regardless of its complexity. The purpose is to minimize the electric field and the biased roulette wheel method explained in chapter three is used for reproduction.

Then the GA main program uses the calculated fitness values and the citizens of the population to generate the next generation of citizens using the GA operators (reproduction, crossover, mutation.....etc.). The new generation is considered as a new input population and the process is repeated for a certain number of generations or until the acceptable error is reached. If this task is repeated for a certain number of generations and the final resulting error doesn't meet the acceptable range of error, then the best citizen in the last generation is injected manually to the initial population of a new running session. Thus, if the GA program runs for insufficient number of generations, the search can be completed by running the program again using the previous GA best results without having to begin the search again from the starting point.

4. Results and discussions

Case study 1: A 400 kV homopolar transmission line with and without grounded shield wires:

1) Without grounded shield wires

The charge simulation method is applied to the 400 kV homopolar transmission line shown in Fig. 2. The radius of pole conductors R_c is 0.0383m, the clearance d between poles is 22 m and the height H is a variable parameter. The number of simulation line charges per conductor equals six. The simulation charges are arranged around a cylinder of radius equal to $0.05R_c$. The potential error at selected contour points does not exceed 0.001%.

Figure 3 shows the electric field at 1m height above the ground level for the configuration shown in Fig. 2. The maximum field strength at 400 kV applied voltage is found to be about 14.2 kV/m and corresponds to minimum ground clearance $H=10 \text{ m}$. Increasing the line height is the most effective parameter in line design, which reduces the maximum field stress at ground.

Figure 3 plots the field strength for different line heights of 10, 14, 18, 22 and 27 m. The maximum field stress values corresponding to these line heights are 14.2, 10.45, 8.54, 7.32 and 6.11 kV/m^{-1} respectively. It is clear that as the line height increases, the maximum field decreases with a significant amount within the transmission line corridor. Outside the line corridor, it is influenced by a completely different way. Table 1 lists the ROW widths for the transmission line configuration shown in Fig. 2 for different line heights and the corresponding electric field stress at the border of ROW.

2) With grounded shield wires

The charge simulation method is applied to the transmission line shown in Fig. 4. The radius of pole conductors R_c is 0.0383m, the clearance d between poles is 22 m, the height H is 27 m from conductor to ground. The radius of shield wires r_{sh} is 0.0039 m, the spacing between grounded shield wires is S and the height from shield conductor to ground H_s .

The number of simulation line charges for both pole conductors and shield wires is equal to six. The simulation charges are arranged around a cylinder of radius equal to $0.05R_c$ for pole conductors and $0.05r_{sh}$ for shield wires. The potential error at selected contour points on the line conductors and grounded shield wires did not exceed 0.001%.

Different number of grounded shield wires, different spacings S between grounded shield wires and different heights H_s from ground to grounded shield wires are studied.

Figures 5 and 6 show plots of the electric field at 1m height above the ground level for the configuration shown in Fig. 4 at $H_s=15\text{m}$ with different number n_s of grounded shield wires and spacings $S=1$ and 6 m between shield wires.

From Figs.5 and 6, it is clear that the maximum electric field decreases with the increase of the number n_s of shield wires increase and the spacing S in between. Table 2 lists the ROW widths for the transmission line shown in Fig. 4 for spacing of one and five meters and its percentage reduction due to the presence of shield wires.

Case Study 2: A 400 kV bipolar transmission line with and without grounded shield wires

The grounded shield wires are centered underneath each pole as shown in Fig. 7. The configuration of this transmission line is the same as that in Fig. 4.

Figures 8 and 9 show the electric field at 1m height above the ground level for the configuration shown in Fig. 7 at $H_s=15\text{m}$ with different spacings S between shield wires and different numbers n_s of grounded shield wires.

In Fig. 8, the maximum electric field stress is 3.3 kV m^{-1} without shield wires. It decreases with the presence of shield wires and becomes 1.86, 1.7 and 1.6 kV m^{-1} for 1, 2 and 3 wires respectively. With the increase of n_s above three, there is no noticeable reduction change in maximum electric field. With the increase of the number of grounded shield wires over three, there is no noticed change in maximum electric stress.

In addition, Fig. 9 shows the electric field distribution at 1m above the ground level with 3m spacing between shield wires.

Table 3 lists the ROW for the transmission line shown in Fig. 7 for $S=1, 3\text{m}$ and its percentage reduction due to presence of shield wires. It is noted from the table that the saving of ROW in case of bipolar transmission line with three shield wires equal three and spacing S of three meters reaches up to 44%.

Case Study 3: The use of GA on 400 kV monopolar Transmission Line with shield wires

The genetic algorithm is applied to a 400 kV high voltage direct current transmission line shown in Fig. 4. The radius of pole conductors $R_c=0.0383\text{ m}$, the clearance between poles is $d=22\text{ m}$, the height $H=27\text{ m}$ from conductor to ground level, the radius of grounded shield wires $r_{sh}=0.0039\text{ m}$, the spacing between grounded shield wires is S , the height from grounded shield wires to ground level H_s , and the number of grounded shield wires are n .

The previously explained genetic algorithm is used to determine the number of grounded shield wires and their best location to reduce electric field at the surface of ground level to reduce ROW. The ranges of the input variables of the proposed system are:

Number of grounded shield wires is between one and six, the spacing between grounded shield wires is between 0.1 and 6 m and the height from grounded shield wires to ground level is between 1 and 15 m.

As mentioned before, the number of bits in a binary string needed to represent the parameters is 37 bit in a binary code shown in Tables 4 and 5.

Calculating the objective function at the selected individuals and applying the genetic algorithm selection process using the roulette wheel method to select the chromosomes, which will be used in generating the new generation, this illustrated in Table 6.

After reproduction by using roulette wheel method of selection

String 2 and string 3 receiving one copy in the mating pool.

String 1 receiving two copies.

String 4 receiving no copies.

Applying the genetic operators, crossover processes with a probability of 95% and mutation process with a rate of 0.001 on the selected individuals and put them in the new generation, this process is illustrated in Tables 7, 8, 9 and 10.

Floating point GA with maximum number of generations of one thousand and population size of fifty are used. The solution converged after one hundred and twenty generations to a number of five grounded shield wires. The spacing between grounded shield wires equal six meters and the height from ground level to grounded shield wires H_s equal to fifteen meters.

5. Conclusions

The maximum electric field at the ground level (one meter above ground surface) for homopolar and bipolar transmission lines decreases with the increase of the spacing S between shield wires irrespective of the

height H_s and the number n_s of wires.

The maximum electric field at the ground level (one meter above ground level) for homopolar and bipolar transmission lines decreases with the increase of the number n_s of shield wires whatever the spacing S or the height H_s of the grounded wires.

The ROW of homopolar and bipolar transmission lines decreases with the increase of the number n_s of shield wires whatever the spacing S or the height H_s of the wires.

The ROW of homopolar and bipolar transmission lines decreases with the increase of the spacing S between shield wires irrespective of the height H_s and number n_s of grounded wires.

GA approach has showed that its results are more accurate than the previous experience based results. It also shows that the best location of grounded shield wires is at height of 15 m above ground level for five grounded shield wires at spacings of 6 m.

References

- E.W. Kimbark (1971), *Direct Current Transmission, Volume 1*. New York: John Wiley & Sons.
- Mazen Abdel-Salam and Hassan Mohamed Abdallah (1995), "Transmission line Electric field induction in humans using charge simulation method" *IEEE Transaction on biomedical engineering* Vol. 42, No.11.
- Gunatilake A, Wang Z, Cotton I (2004), "Use of wooden structures to reduce electric field under EHV transmission lines" *Proceeding of the 39th International Universities Power Engineering Conference (UPEC)*, Vol. 1, 6-8 September, pp.223 – 227.
- Deno, D.W (1977) "UHV Transmission line electric field reduction with a set of horizontal wires" *IEEE Trans. PAS* Vol. 96, No.5, pp. 1507– 1516.
- Yuji Amano, Yoshitaka Sunaga (1989), "Study on reduction in electric field, charged voltage, ion current and ion density under HVDC transmission lines by parallel shield wires" *IEEE Trans. on power delivery* Vol. 4, No. 2.
- Hanafy M.Ismail (1999) "Shielding design methods for Kuwait high voltage double circuits electrical networks" *International conference on electric power engineering, Budapest*.
- Hanafy M.Ismail, A.R. Abu-Gammaz (1999), "Electric field and right of way of Kuwait high voltage transmission system" *Electric power systems research*, pp. 213 – 218.
- Deno, D W Sr, Zaffanella, L E, Silva, J M (1987), "Transmission line electric field shielding by objects" *IEEE Transactions on Power Delivery*. Vol. 2, No. 1, pp.269 – 280.
- Tadasu Takuma, Tadashi Kanwamoto, Mitsuru Yasui, Mitsuharu Murooka and Jun Katoh (1985) "Analysis of effect of shield wires on electrostatic induction by ac transmission line" *IEEE Trans. PAS*, vol.104, no. 9.
- H. Singer, H. Steinbigler and P. Wiss (1974), "A charge simulation method for calculating high voltage fields", *IEEE Transactions on PAS*, Vol.93, pp. 1660–1668.
- N. H. Malik, "A review of the charge simulation method and its applications (1989) " *IEEE Transactions, on Electrical Insulation*, vol. 24, no. 1, pp 3–20.
- Cruz, P., Izquierdo, C. and Burgos, M. (2003), "Optimum Passive Shields for Mitigation of Power Lines Magnetic Field", *IEEE Transaction on Power Delivery*, vol. 18, no. 4, pp. 1357 – 1362.
- Radwan, R. M., Abdel-Salam, M., Mahdy, A.M. and Samy, M.M. (2010) "Mitigation of Electric Fields Underneath EHV Transmission Lines Using Active and Passive Shield Wires," *Proceedings of the 8th Regional Conference for National Committee of CIGRE in the Arab Countries*, October 18-20, Doha, Qatar.
- M. M. Samy, M. Abdel-Salam, and Abd-elatif M. El-Zein (2008), "Electric Field Profiles and Right-of-Way Widths as Influenced by Grounded Shield Wires Underneath EHV Direct Current Transmission Lines" *Proceedings of the 6th International Conference on Electrical Engineering (ICEENG)*, pp. 1 – 12, 27–29 May, Military Technical College, Cairo, Egypt.
- R. M. Radwan, M. Abdel-Salam, A. M. Mahdy and M. M. Samy (2011), "Laboratory Validation of Calculations of Magnetic Field Mitigation Underneath Transmission Lines Using Passive and Active Shield Wires," *Innovative Systems Design and Engineering Journal*, ISSN 2222-1727 (Paper) ISSN 2222–2871 (Online), vol. 2, no. 4, pp. 218–232.
- R. M. Radwan, M. Abdel-Salam, A. M. Mahdy and M. M. Samy (2013) "Electric Field Mitigation Underneath Extra High Voltage Power Lines," *IEEE Transaction on Dielectric and Electrical Insulation*, vol. 20, no.1, pp. 54 – 62.



M. M. Samy was born in Egypt in 1972. He received the B.S. degree in electrical engineering from Faculty of Engineering, Benha University, Benha Egypt, M.S. degree in electrical power and machines from Zagazig University, Zagazig, Egypt, and Ph.D. degree in electrical power and machines from Cairo University, Giza, Egypt, in 1995, 2007 and 2011, respectively. Currently he is an assistant Prof. in electrical engineering department at the faculty of Industrial Education, Beni Suief University, Beni Suief, Egypt. His research activities include digital calculation of electric and magnetic fields, mitigation of electromagnetic fields underneath high voltage transmission lines, Grounding, digital protection of power system.

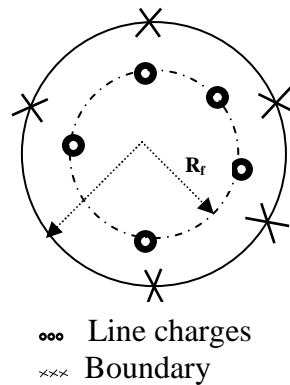

Fig. 1: Charge representation for the line conductor and shield wires.

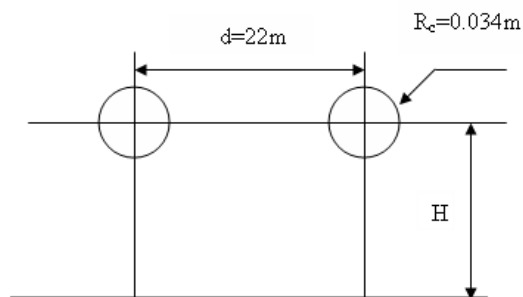

Fig. 2: A 400kV, homopolar HVDC Transmission Line

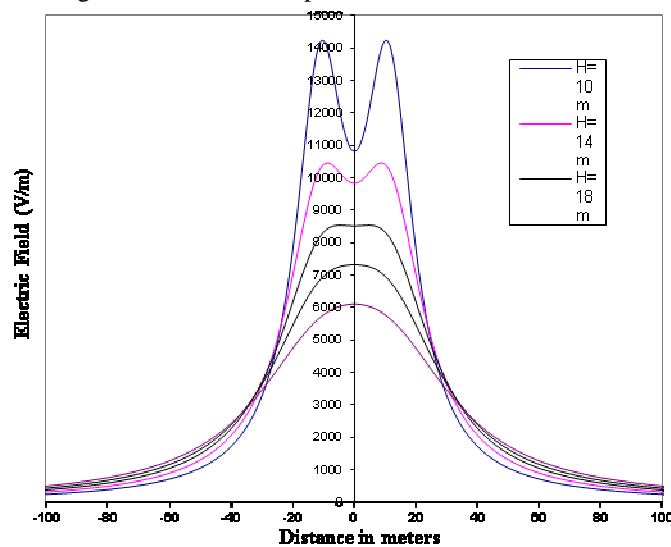

Fig.3: Electric field distribution at 1m height above ground surface for 400 kV TL of Fig.2 with the line height H as a parameter

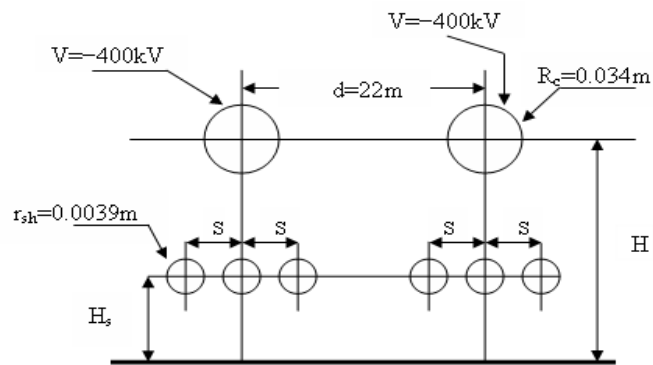

Fig. 4: A 400kV- Homopolar HVDC Transmission Line with grounded shield wires

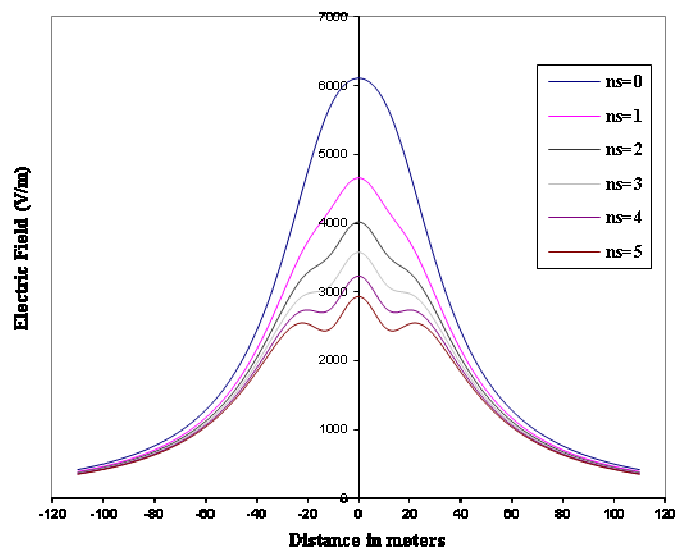

Fig. 5: Electric field distribution at 1m height above ground surface of the homopolar line with $S=1$ and $H_s=15m$

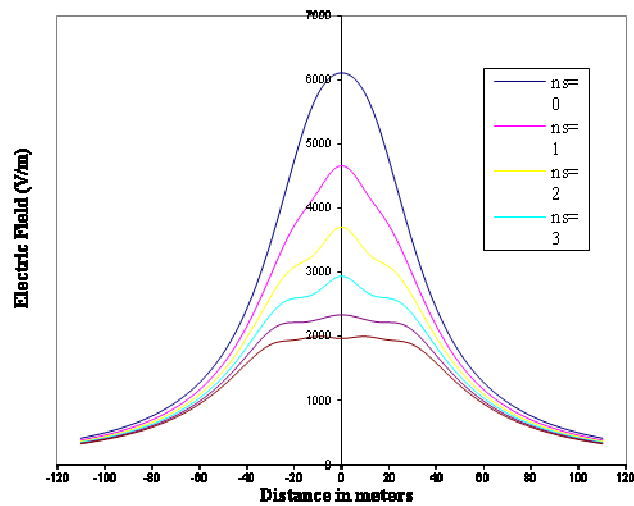

Fig. 6: Electric field distribution at 1m height above ground surface of the homopolar line with $S=6m$ and $H_s=15m$

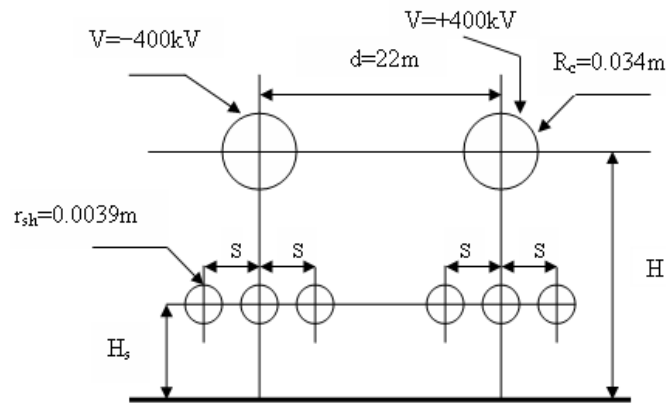

Fig. 7: A \pm 400kV- bipolar HVDC Transmission Line with grounded shield wires

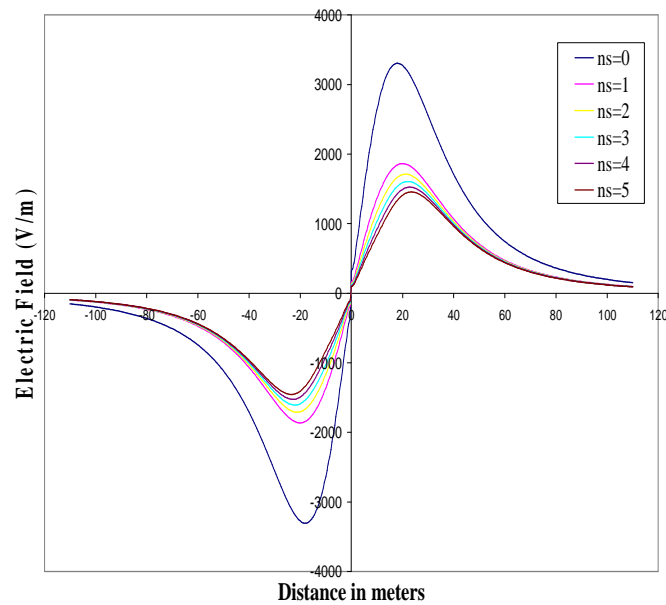

Fig. 8: Electric field distribution at 1m height above ground surface of the bipolar line with $S=1$ m

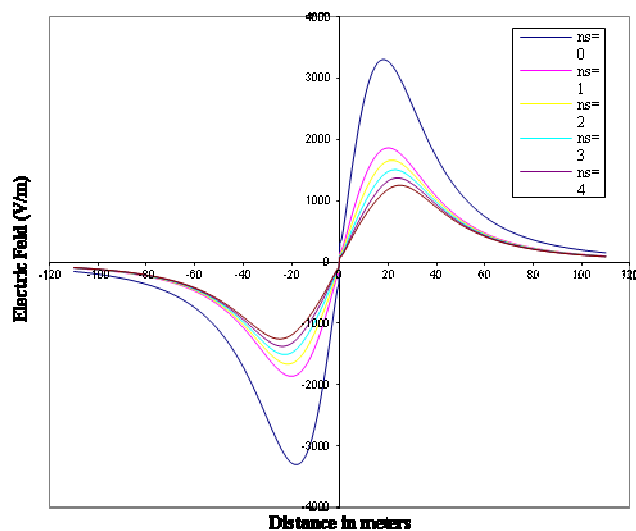

Fig.9: Electric field distribution at 1m height above ground surface of the bipolar line with $S=3$ m

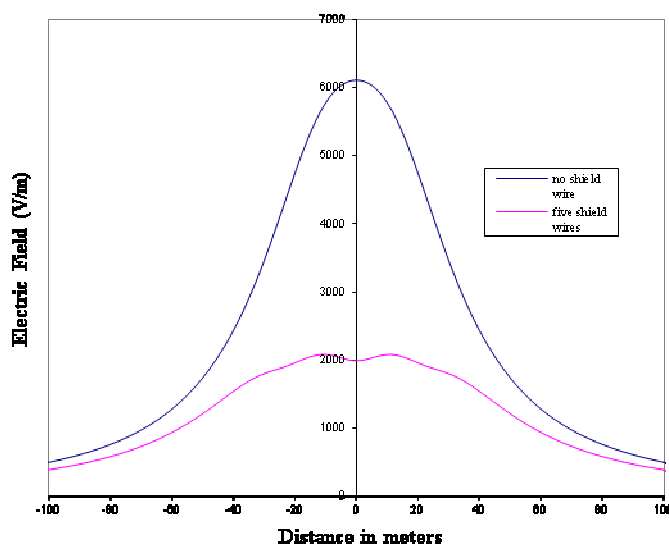

Fig. 10 Electric field distribution at 1m height above ground surface for Fig. 5.3 with S=6m

Table 1: ROW widths for the homopolar transmission line.

Line height H (m)	Electric field (kV/m)	Required ROW (m)
10	0.5	71
	1	51
	1.5	42.5
14	0.5	80
	1	57
	1.5	46.5
18	0.5	87
	1	61.5
	1.5	50
22	0.5	93
	1	65
	1.5	52.25
27	0.5	99.5
	1	69
	1.5	54.5

Table 2: ROW widths for the homopolar transmission line with S of 1, and 5m and Hs=15m

Number of shield wires	Electric field (kV/m)	Required ROW (m)		Percentage reduction of ROW	
		S=1m	S=6m	S=1m	S=6m
no	0.5	99.5	99.5		
	1	69	69		
	1.5	54.5	54.5		
1	0.5	99	99	0.5%	0.5%
	1	68.5	68.5	0.72%	0.72%
	1.5	54.25	54.25	0.45%	0.45%
2	0.5	93.5	93	5.5%	6.5%
	1	63.5	63.5	7.2%	8%
	1.5	49.5	49	8.25%	10.1%
3	0.5	91.5	91	7%	8%
	1	62	61.5	8.7%	10.8%
	1.5	47.5	49	10.55%	10.1%
4	0.5	90	89	8%	10.55%
	1	60.5	59.5	10.14%	13.76%
	1.5	46	44.75	12.38%	17.9%
5	0.5	88.5	87.5	9%	12%
	1	59	58	11.23%	15.9%
	1.5	44.75	42.25	13.76%	22.47%

Table 3: ROW widths for the bipolar transmission line with S of 1 and 3 m and Hs=15m

Number of shield wires	Electric field (kV/m)	Required ROW (m)		Percentage reduction of ROW	
		S=1m	S=3m	S=1m	S=3m
no	0.5	70.5	70.5		
	1	52.4	52.4		
	1.5	43	43		
1	0.5	58.5	58.5	17%	17%
	1	41.5	41.5	20.8%	20.8%
	1.5	31	31	24.8%	24.8%
2	0.5	58	57.5	17.7%	18.4%
	1	40.75	40.5	22.2%	22.7%
	1.5	29.5	28.75	31.39%	33.1%
3	0.5	57.5	57	18.4%	19.1%
	1	40	39.4	23.6%	24.8%
	1.5	27.75	24	35.4%	44.18%

Table .4 Coding of variables of the proposed problem for the first generation

Ind. No.	# of grounded shield wires		Spacing between grounded shield wires		Height from ground to grounded shield wires	
	Parameter value	Decimal value	Parameter value	Decimal value	Parameter value	Decimal value
1	1	0	0.1	0	1	0
2	3	1365	2.9815629	2000	7.83677210	4000
3	5	2730	5.1427350	3500	10.4005620	5500
4	7	4095	6	4095	15	8191

Table 5 Coding of individuals for the first generation

Individual No.1	0000000000000000000000000000000000
Individual No.2	010101010101111110100000111110100000
Individual No.3	1010101010101101101011001010101111100
Individual No.4	11

Table 6 Selection process using roulette wheel

Individual No.	Objective function	Ratio to total	Expected count	Actual count
1	4660.236	0.3636875	0.3636875x4=1.4547	2
2	4148.204	0.3237282	0.3237282x4=1.294	1
3	2289.388	0.1786651	0.1786651x4=0.7146	1
4	1716.018	0.133919	0.133919x4=0.5357	0

Table 7 Crossover processes

Ind. No.	Mating pool after reproduction	Mate	Crossover site
1	0000000000000000000000000000000000	1	29
2	010101010101111110100000111110100000	2	29
3	0000000000000000000000000000000000	1	30
4	10101010101101101011001010101111100	3	30

Table 8 Mutation process

Ind. No.	After crossover	Mutation site
1	0000000000000000000000000000000010100000	18
2	010101010101011111010000011110000000	30
3	000000000000000000000000000000001111100	36
4	101010101010110110101100101010000000	13

Table 9 New populations

Ind. No.	New populations
1	000000000000000010000000000010100000
2	010101010101011111010000011111000000
3	000000000000000000000000000000001111110
4	1010101010010110101100101010000000

Table 10 Decoded values of new populations

Ind. No.	# of grounded shield wires	Spacing grounded between shield wires	Height from ground to grounded shield wires
1	1	0.1461050	1.54694180
2	3	2.9815629	7.78207790
3	1	0.1000000	10.4005620
4	5	2.1920147	10.1886220

The IISTE is a pioneer in the Open-Access hosting service and academic event management. The aim of the firm is Accelerating Global Knowledge Sharing.

More information about the firm can be found on the homepage:
<http://www.iiste.org>

CALL FOR JOURNAL PAPERS

There are more than 30 peer-reviewed academic journals hosted under the hosting platform.

Prospective authors of journals can find the submission instruction on the following page: <http://www.iiste.org/journals/> All the journals articles are available online to the readers all over the world without financial, legal, or technical barriers other than those inseparable from gaining access to the internet itself. Paper version of the journals is also available upon request of readers and authors.

MORE RESOURCES

Book publication information: <http://www.iiste.org/book/>

IISTE Knowledge Sharing Partners

EBSCO, Index Copernicus, Ulrich's Periodicals Directory, JournalTOCS, PKP Open Archives Harvester, Bielefeld Academic Search Engine, Elektronische Zeitschriftenbibliothek EZB, Open J-Gate, OCLC WorldCat, Universe Digital Library, NewJour, Google Scholar

