

Development of a Microcontroller Based Car Speed Controller

Jonathan A. Enokela David O. Agbo

Department of Electrical and Electronics Engineering, Federal University of Agriculture,
P.M.B. 2373, Makurdi, Benue State, Nigeria

E-mail of the corresponding author: jonajapeno@gmail.com

Abstract

Nigeria and many countries of the world have been experiencing an increase in road traffic accidents much of which can be attributed to human errors such as over speeding. The car speed controller discussed in this work is designed to automatically control the speed of a car so that the car's speed will not exceed the speed limit that has been set for a particular zone by a regulating body such as the Federal Road Safety Commission (FRSC) in Nigeria. The car speed controller operates by taking inputs from a set of three switches that can set speed limits in kilometers per hour of 40, 80, and 120 respectively. Each setting of the switch is compared with the actual speed of the car that is derived from the car's speedometer. If the speed of the car exceeds the setting, an actuator is called into operation such that the car's speed is not allowed to exceed the set limit for the zone. A microcontroller was programmed to take inputs from the switches and the speedometer; depending on the settings the microcontroller turns on light emitting diodes (LEDs) and displays appropriate messages on the screen of a liquid crystal display (LCD). In the simulation model a stepper motor was controlled by the microcontroller through a motor driver to represent the adjustment of speed in the real environment. The program for the microcontroller was written using mikroC development environment and hardware simulation was carried out with the aid of Proteus Design Suite Version 8.0. The speed settings for a zone can be altered to suite the choice of a regulatory agency. The installation of the car speed controller in vehicles will not only give early warnings to drivers but will prevent over speeding thus leading to the reduction in cases of road traffic accidents.

Keywords: Car Speed Control, Speed Governor, Microcontroller, Road Safety

1. Introduction

Nigeria and the generality of the countries in the world lose a great number of their citizens in cases of road traffic accidents every year (Omidiji & Ibitoye 2010). The report by the Federal Road Safety Commission (FRSC) of Nigeria in 2013 shows that as much as 32% of all accidents that occurred that year were attributed to speed related issues (Federal Road Safety Corps 2013). Different types of technologies have been deployed over the past three decades with a view to controlling the speed of automobiles in order to reduce the cases of fatal accidents. Akihiko *et al.* (1990) patented an automatic car speed controller whose driving circuit is operated by the difference between the actual car speed and the memorized car speed; the difference signal is used to operate an electromagnetic clutch. A similar system is also reported in Akihiko *et al.* (1992). The systems discussed in Akihiko *et al.* (1990) and Akihiko *et al.* (1992) have been rendered obsolete by newer and improved car manufacturing technologies. More modern systems that use electro-hydraulic braking systems and electronic control of throttles are reported by Santoshi *et al.* (2015), Eswaramoorthy & Araunkumar (2014), and Saivignesh *et al.* (2015).

Bianco *et al.* (2013) used the notation of the Unified Modeling Language (UML) to theoretically model a car speed regulator. An electronic system to control car speed using two variable resistors for generating speed control signals that are processed and transformed into a digital signal for controlling the driving speed of an electric car is discussed in the work by Byum (1998). A system that uses the Radio Frequency Identification (RFID) for identification of traffic signals on the road and also for infrastructure to vehicle communication is reported by Perez *et al.* (2010). This elaborate system not only controls the speed of vehicle and shows its location using the global positioning system (GPS) but is also capable of avoiding vehicle to road infrastructure collisions. This system employs many sensors and electronics and this fact will make it to be costly. Other systems that are based on RFID and RF transmitter- receiver pairs are reported in Madhu *et al.* (2014), Thomas *et al.* (2014) and Kameswari *et al.* (2011). These systems require the installations of an extensive road infrastructure in the form of roadside beacons.

The most modern autonomous system that uses the GPS for the location of vehicles and control of speed is the Intelligent Speed Adaptation (ISA) (Paine 2008; Carsten & Tate 2005, and Paine *et al.* 2008). This system uses the GPS within the vehicle to determine its location. A memorized digital map included in the system enables the speed limit of the location to be determined so that the driver can be properly advised to stay within this prescribed speed limit. This complex system will certainly require the availability of the satellite system that forms the GPS, a detailed construction of the digital maps of all the roads in a country where it is deployed as well as the availability and maintenance of good roads. These factors may not always exist in

developing countries.

The system described in this work is a purely advisory type as it does not take any active measures to operate the braking or the throttling of the car; this aspect is however successfully simulated in the work using a dc motor. The system uses visual indicators i.e. light emitting diodes (LED) and writes messages on the screen of a liquid crystal display (LCD) to alert the driver of the necessity to stay within prescribed speed limits. An audible alarm is also triggered when the driver exceeds the speed limit. The system described in this work is simple to operate and is also much cheaper than the other systems that have been earlier described in the literature review.

2. Materials and Methods

The block diagram of the system is depicted in figure 1. The inclusion of a microcontroller into the system makes it to be a stand-alone type of system that is capable of taking decisions to keep the system functioning properly. The microcontroller receives input signals from the speed limit switches and the digitized actual car speed. In this work three switches are used to set the speed limits at 40 km/hr, 80 km/hr, and 120 km/hr. These speed limits may be altered as desired. The actual car speed may be measured by using several methods one of which is the detecting of the pulses generated by the ignition system (Linscott, 2001). A more accurate method involves the use of sensors such as the Hall effect based sensor (Perez *et al.* 2010 & Vehicle Speed Sensors 2003).

The system operates by comparing the digitized car speed with the value of the speed limit set by the user. Depending on the result of the comparison a decision is taken to light up the appropriate LED and also to write a message on the screen of the LCD. An audible alarm is sounded if the set speed limit is exceeded by the driver. The flowchart of the program executed by the microcontroller is shown in figure 2. This shows that the microcontroller polls the input sensors and depending on their states an appropriate decision is taken after which the microcontroller goes back to monitoring the sensors in a continuous loop.

The circuit used for the simulation of the operations of the car speed controller was built in the environment of Proteus Design Suite Version 8.0 (Labcenter Electronics 2014) and is shown in figure 3. A variable resistor RV2 shown in figure 3 is used to represent the actual speed of the car. One of the transistor switches (Q1-Q3) is used for one of the desired speed limits. The microcontroller is programmed to turn on the green, red, or yellow LED as appropriate and to also write a message on the screen of the LCD. An audible alarm system is turned on by the microcontroller when necessary.

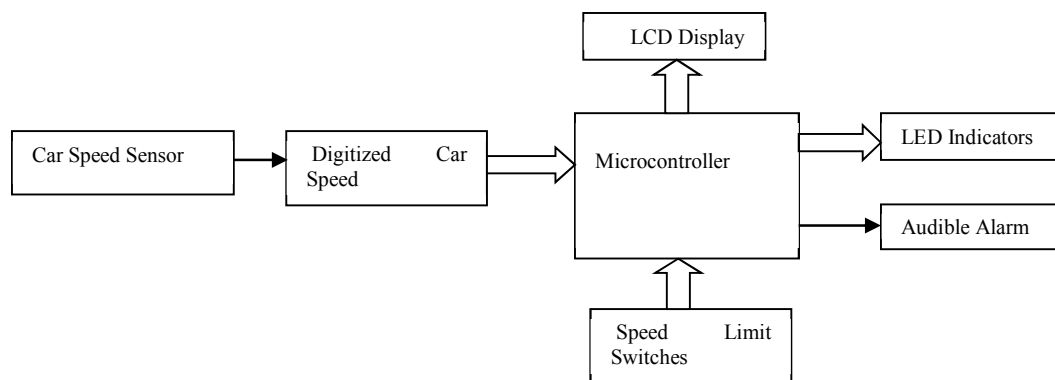

Figure 1. Block Diagram of Automatic Car Speed Controller System

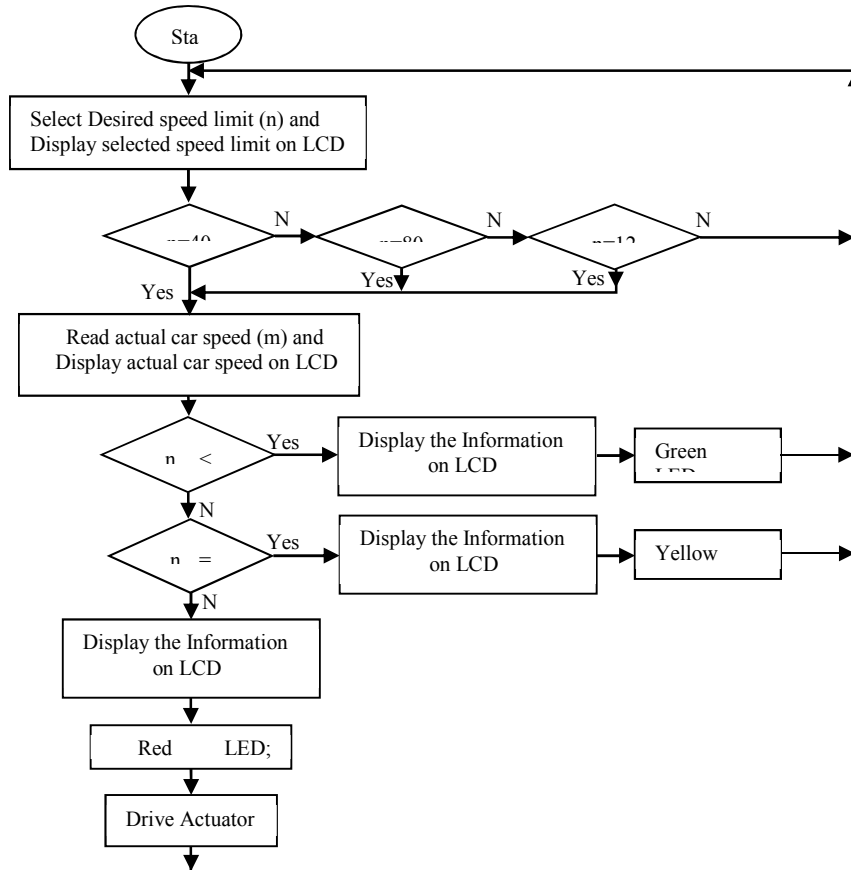

Figure 2. Flowchart of Program for the Automatic Car Speed Controller

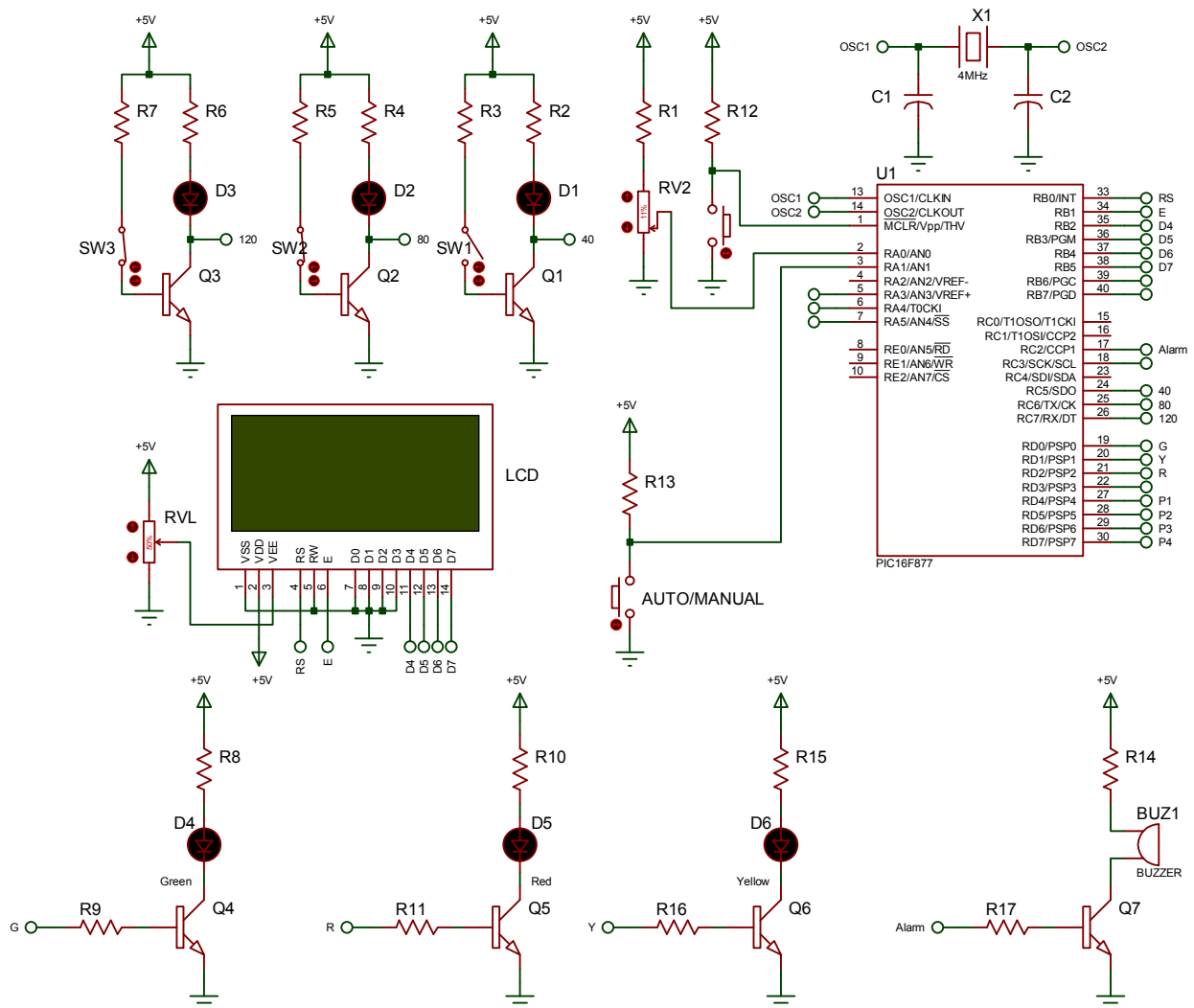

Figure 3. Schematic Diagram of the Simulation Circuit of the Speed Controller

3. Results and Discussions

The program for the microcontroller was written in C language and was then compiled into an executable file using the mikroC IDE Version 6.0 (MikroElektronika 2013). A software simulation was carried out with the simulator built into the mikroC IDE to ensure that the program variables and registers changed as desired. The executable file was next imported into the Proteus Design Suite IDE where the hardware circuit shown in figure 3 was constructed and simulated. The program development in mikroC IDE is shown in figure 4. Figures 5 and 6 show the simulation results for the case where the car speed is less than the set speed limit and another where the car speed is greater than the set speed limit, respectively. Table 1 shows the three possible conditions of the set speed switches and the outputs of the microcontroller. Upon successful completion of the software simulation, the system's hardware was constructed on a vero board and hardware simulation was further carried using MPLAB ICD 2 In-Circuit debugger (Microchip Technology Inc. 2006). The process is shown in figure 7.

```

mikroc PRO for PIC v.6.0.0 - C:\Users\Florence\Documents\simulations\PIC\simulations\c\language\carSpeedcontroller\CarSpeed.LCD.mcppi - NOT REGISTERED
File Edit View Project Build Run Tools Help
Debug layout
Start Page CarSpeed.CD.c
/*
 * Project name: Car speed controller
 * MCU: PIC16F887
 * Oscillator: HS, 04.0000 MHz
 * SW: mikroC PRO for PIC
 */

// lcd module connection
sbit LCD_RS at RB0_bit;
sbit LCD_EN at RB1_bit;
sbit LCD_D4 at RB2_bit;
sbit LCD_D5 at RB3_bit;
sbit LCD_D6 at RB4_bit;
sbit LCD_D7 at RB5_bit;

sbit LCD_RS_Direction at TRISB0_bit;
sbit LCD_EN_Direction at TRISB1_bit;
sbit LCD_D4_Direction at TRISB2_bit;
sbit LCD_D5_Direction at TRISB3_bit;
sbit LCD_D6_Direction at TRISB4_bit;
sbit LCD_D7_Direction at TRISB5_bit;
// end lcd module connections
    
```

Line	Message No.	Message Text	Unit
0	1004	COFF file successfully generated	COFF file successfully generated
0	128	Linked in 843 ms	
0	129	Project 'CarSpeed.LCD.mcppi' completed: 1201 ms	
0	103	Finished successfully: 08 Apr 2015, 13:53:40	CarSpeed.LCD.mcppi

Figure 4. Program Development using mikroC IDE

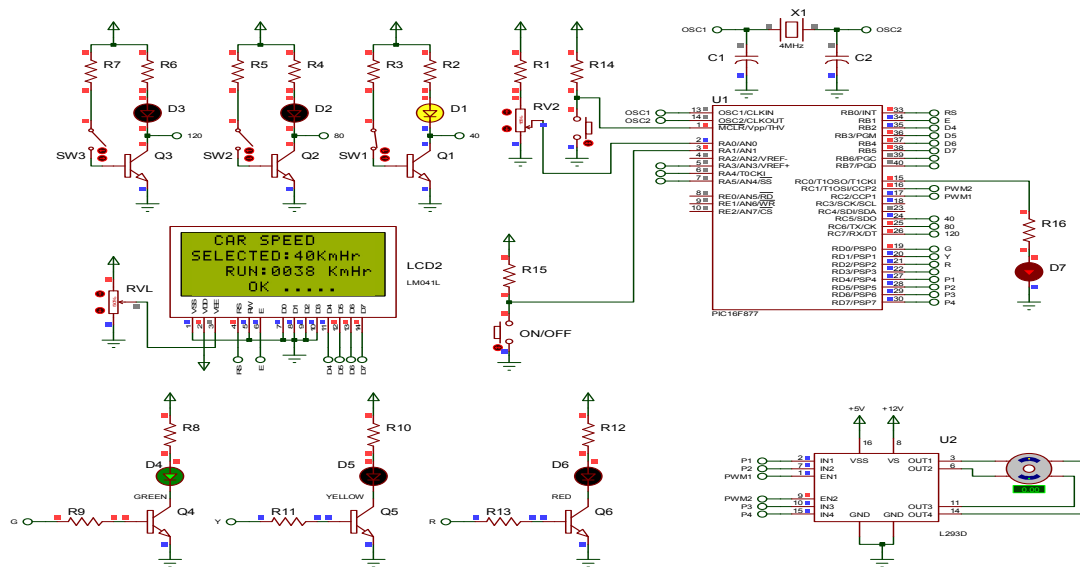

Figure 5. Simulation Result for Car speed less than the set speed limit

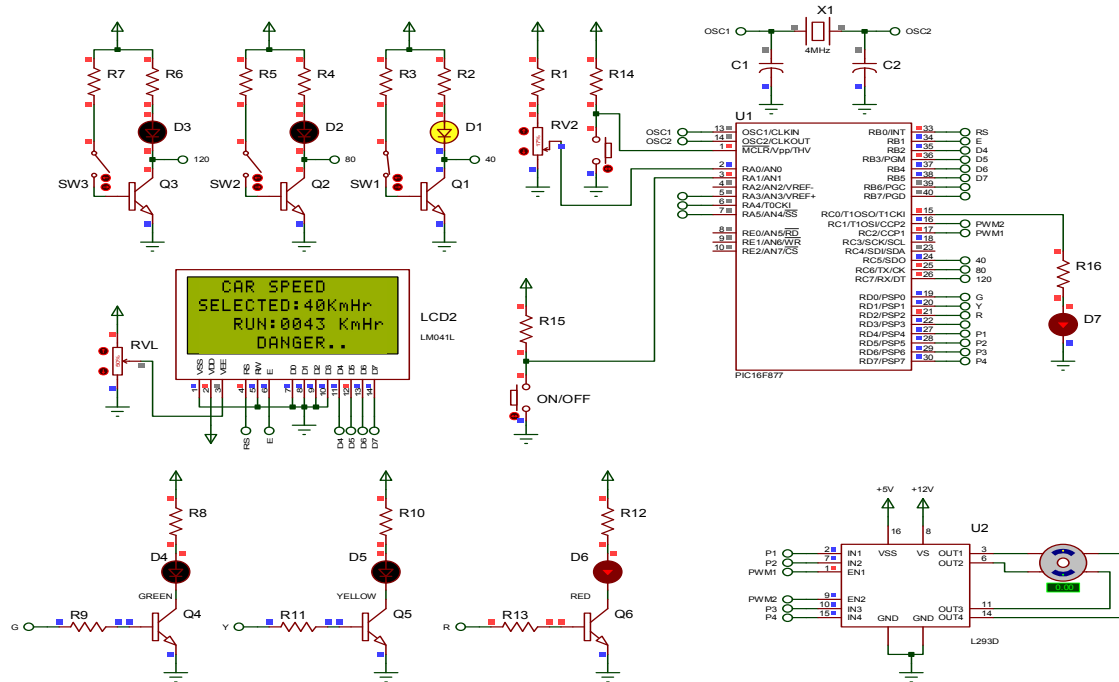

Figure 6. Simulation Result for Car speed greater than the set speed limit

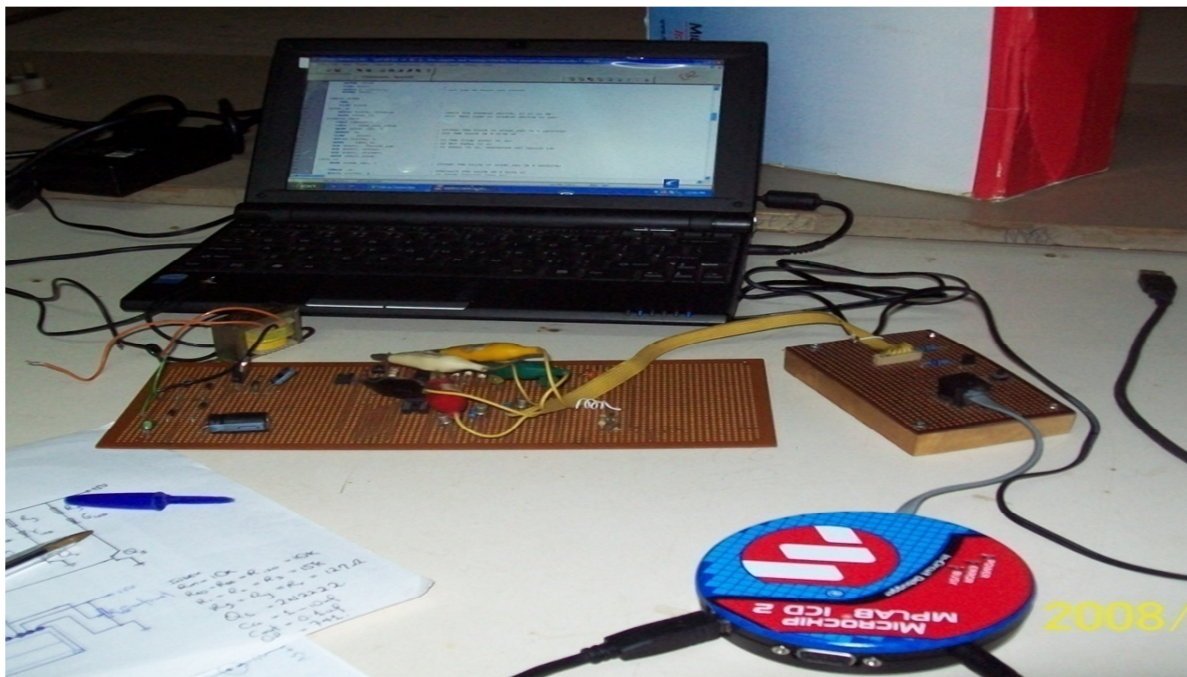

Figure 7. Programming the microcontroller and Hardware Debugging Process

Table 1. Set Speed Switches Conditions and Microcontroller Decisions

Switches Conditions			Set Car Speed Limit	Microcontroller Output
S1	S2	S3		
H	H	L	40 km/h	Any of Green, Yellow, or Red LED may be turned on depending on actual car speed; Appropriate message is displayed on LCD; Alarm is on and stepper Motor turns 90° when car speed is greater than set speed.
H	L	H	80 km/h	Any of Green, Yellow, or Red LED may be turned on depending on actual car speed; Appropriate message is displayed on LCD; Alarm is on and stepper Motor turns 180° when car speed is greater than set speed.
L	H	H	120 km/h	Any of Green, Yellow, or Red LED may be turned on depending on actual car speed; Appropriate message is displayed on LCD; Alarm is on and stepper Motor turns 270° when car speed is greater than set speed.

Note that in table 1; L = Low Logic Level Signal and H = High Logic Level Signal.

4. Conclusions

The automatic car speed controller system has been designed and implemented using a microcontroller. Due to the few number of components used the system has a high degree of reliability. This fact also makes the system to be low cost thus making it suitable for deployment in developing countries. The system has been designed to be purely advisory to the driver since the control of the throttle or the braking system has not been physically implemented. The successful simulation of this aspect using a dc motor, however, shows the feasibility of its implementation.

References

- Omidiji, A.A. & Ibitoye, S.A. (2010), "Crime and Road Crashes Prevention in Public Transportation System in Nigeria: the Case Study of Kwara, Kogi and Ekiti States", 24th ARRB Conference- Building on 50 years of Road and Transport Research, Melbourne, Australia.
- Federal Road Safety Corps, Federal Republic of Nigeria Annual Report (2013), "Road Crash Statistics", [Online] Available: <http://frsc.gov.ng/2013%FRSC%20Annual%20Report.pdf> (February 10, 2015)
- Akihiko, T., Iwaoka, T., Yamaguchi, Y. & Danzaki, T. (1990), "Automatic Car Speed Controller with Detection of Abnormality of the Electromagnetic Clutch", United States Patent Number 5014201. [Online] Available: <http://www.patents.com/us-5014201.html> (December 10, 2014).
- Akihiko, T., Iwaoka, T., Yamaguchi, Y. & Danzaki, T. (1992), "Automatic Car Speed Controller", United States Patent Number 5107947. [Online] Available: <http://www.freepatentsonline.com/5107947.pdf> (December 10, 2014).
- Santoshi, G.V.L., Hima, B.N. & Uma, R.K. (2015), "Intelligent Vehicle Control Based on Identification of Road and Traffic Signal Operated RFID Transponders", International Journal of Engineering Research and Applications, National Conference on Developments, Advances, and Trends in Engineering Sciences (NCDATES). pp. 40-45. [Online] Available: http://www.ijera.com/special_issue/NCDATES/ECE/PART-5/ECE%20120-4045.pdf (February 13, 2015).
- Eswaramoorthy, P. & Arunkumar, M. (2014), "Intelligent Vehicle Control Based on Identification of Road Signs by Solar Powered RFID Transponders", *International Journal of Research in Engineering and Technology*, 3, 85-89.
- Saivignesh, H., Mohamed, SM., Nagaraj, M., Sharmila, B. & Nagaraja, P.M. (2015), "RF Based Automatic Vehicle Speed Limiter by Controlling Throttle Valve", *International Journal of Innovative Research in Science, Engineering and Technology*, 4, 18722-18728.
- del Bianco, V., Luigi, L. & Marco, M. (2013), "An Application of the DESS Modeling Approach: the Car Speed Regulator", [Online] Available: http://www.researchgate.net/publication/2403852_An_application_of_the_DESS_modeling_approach_The_Car_Speed_Regulator (November 15, 2014).
- Byum, L.S. (1998), "Speed Control Apparatus and Method for Electric Car", United States Patent Number 5726544. [Online] Available: <http://www.patents.com/us-5726544.html> (November 24, 2014).
- Perez, J., Seco, F., Milanes, V., Antonio, J., Diaz, J.C. & de Pedro, T. (2010), "An RFID-Based Intelligent Vehicle Speed Controller using Active Traffic Signals", *Sensors*, 10, 5872-5887. [Online] Available: www.mdpi.com/journal/sensors (January 15, 2015).
- Madhu, Adhulya, R., Singh, S., Sambhavi, & Chauhan, A. (2014), "An Advanced Robotic Car for Accidental Preventions", *International Journal of Engineering Research and Management Technology*, 1, 263-267.

- Thomas, L., James, S.A., Joseph, S., Arya, K.B., Narah, T. & Pangu, O. (2014), “Automatic Speed Control of Vehicles using RFID”, *International Journal of Engineering and Innovative Technology*, 3, 118-120.
- Kameswari, U.J., Satwik, M., Lokesh, A. & Reddy, G.V. (2011), “A Design Model for Automatic Vehicle Speed Controller”, *International Journal of Computer Applications*, 35, 19-24.
- Paine M. (2008), “Comments on Draft Protocol for Speed-Limitation Devices”, [Online] Available: <http://www.mpainesydney.com/idisk/Public/ANCAP%20speed%20limiter%20comments%20mar08.pdf> (February 25, 2015).
- Carsten, O. & Tate, F. (2005), “Intelligent Speed Adaptation: The Best Collision Avoidance System?”, *Proceedings of the 17th Conference on the Enhanced Safety of Vehicles, Netherlands*. [Online] Available: <http://tinyurl.com/26cfod> (February 25, 2015).
- Paine, M., Paine, D., Griffiths, M. & Germanos, G. (2008), “In-Vehicle Intelligent Speed Advisory Systems”, [Online] Available: <http://www-nrd.nhsta.dot.gov/pdf/nrd-01/esv/esv20/07-0247-w-pdf> (January 25, 2015).
- Linscott, R. (2001), “Automotive Speed Indicator”, [Online] Available: <http://www.circuitdb.com/?p=398> (January 25, 2015).
- Vehicle Speed Sensors (2003), [Online] Available: www.jagsthatrun.com/v8-chapters/v8-tpi-speed-sensors.pdf (August 21, 2014).
- Labcenter Electronics (2014), Proteus Design Suite Version 8.0. [Online] Available: <http://www.labcenter.com/> (October 21, 2014).
- Mikroelektronika (2013), mikroC. [Online] Available: www.mikroe.com (October 21, 2014).
- Microchip Technology Inc. (2006), MPLAB ICD 2 In-Circuit Debugger. [Online] Available: <http://www.microchip.com/DevelopmentTools/ProductDetails.aspx?PartNO=dv164005> (July 19, 2010).

The IISTE is a pioneer in the Open-Access hosting service and academic event management. The aim of the firm is Accelerating Global Knowledge Sharing.

More information about the firm can be found on the homepage:

<http://www.iiste.org>

CALL FOR JOURNAL PAPERS

There are more than 30 peer-reviewed academic journals hosted under the hosting platform.

Prospective authors of journals can find the submission instruction on the following page: <http://www.iiste.org/journals/> All the journals articles are available online to the readers all over the world without financial, legal, or technical barriers other than those inseparable from gaining access to the internet itself. Paper version of the journals is also available upon request of readers and authors.

MORE RESOURCES

Book publication information: <http://www.iiste.org/book/>

Academic conference: <http://www.iiste.org/conference/upcoming-conferences-call-for-paper/>

IISTE Knowledge Sharing Partners

EBSCO, Index Copernicus, Ulrich's Periodicals Directory, JournalTOCS, PKP Open Archives Harvester, Bielefeld Academic Search Engine, Elektronische Zeitschriftenbibliothek EZB, Open J-Gate, OCLC WorldCat, Universe Digital Library, NewJour, Google Scholar

