

Constructing Solar Air-Conditioning System for Automobiles

Waleed Momani

Mechanical Engineering Department, Faculty of Engineering Technology, Al-Balqa Applied University, Jordan

Abstract

This paper presents a description and analysis for solar air-conditioning system for automobiles which at the end reduces fuel consumption when it is operated to get comfort in automobiles cabins. Coefficient of performance is used as a measure to compare the traditional air conditioning systems and solar system. It is found that COP of solar AC automobiles is better than other traditional AC systems, no fuel consumption by using solar AC systems in automobiles, also it is found that just one panel of photovoltaic cells is required to offer the required power needed to derive AC for the studied automobile.

Keywords: Air-conditioning, Solar Energy, Photovoltaic, Automobiles, COP.

1. Introduction

Automotive air-conditioning system has played an important role in human comfort and to some extent safety during vehicle driving in varied atmospheric conditions. ASHRAE defining the air conditioning as the science of controlling the temperature, humidity, motion and cleanliness of the air within an enclosure. In a passenger/driver cabin of a vehicle, air conditioning means controlled and comfortable environment in the passenger cabin during summer and winter, i.e., control of temperature (for cooling or heating), control of humidity (decrease or increase), control of air circulation and ventilation (amount of air flow and fresh intake vs. partial or full recirculation), and cleaning of the air from odor, pollutants, dust, pollen, etc. before entering the cabin.[1-4]

While the A/C system provides comfort to the passengers in a vehicle, its operation in a vehicle has twofold impact on fuel consumption: Burning extra fuel to power compressor for A/C operation, and carrying extra A/C component load in the vehicle all the time.

In addition, the A/C running depends on the climatic condition of the concerned geographical region and the time of the year. The most important impact on the fuel economy is when the A/C is running. Clodic et al. (2011) report the additional fuel consumption due to MAC operation as 2.5 to 7.5% (in USA/Europe) considering the climatic conditions, engine type (diesel or gasoline) and user profile. Corresponding CO₂ emission due to MAC operation is between 54.7 and 221.5 kg CO₂ per year per vehicle. Of course, the impact on the fuel consumption is more significant when the A/C is installed in compact and sub-compact vehicles.[2,5,10]

Fig.1 shows the COP for the alternative systems discussed here. The liquid nitrogen system is not included because the air-conditioning is a by-product, obtained without additional energy input.

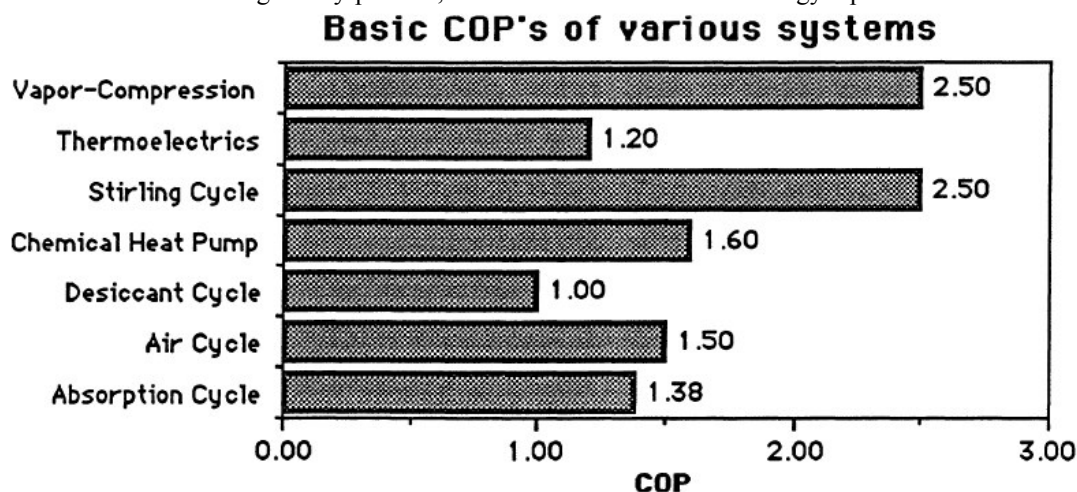

Figure 1: COP of mechanically-driven and waste heat-driven mobile AC systems.

Comparing air-conditioning systems by their basic COP is valid when looking at systems with similar power sources. If the power sources are different, however, some systems will have an unfair advantage over the others. For example, the vapor-compression cycle takes work directly from <shaft power while the absorption cycle uses waste heat. For a fair comparison, the COP for each system is adjusted back to the fuel tank. That is, the COP's are normalized, resulting in:

$$\text{overall COP} = \frac{\text{Heat removed from passenger compartment}}{\text{Heating value of required fuel from tank}}$$

Solar Air-Conditioning System Description and Calculations

Air conditioning's main principles are Evaporation and Condensation, then Compression and Expansion. The refrigeration cycle then runs continuously, and is regulated by the setting of the expansion valve. The whole process is reasonably simple when explained like that. All air conditioning systems work on the same principle, even if the exact components used may vary slightly between car manufacturers. Fig.2 shows the construction of automobile air-conditioning system.[4-8]

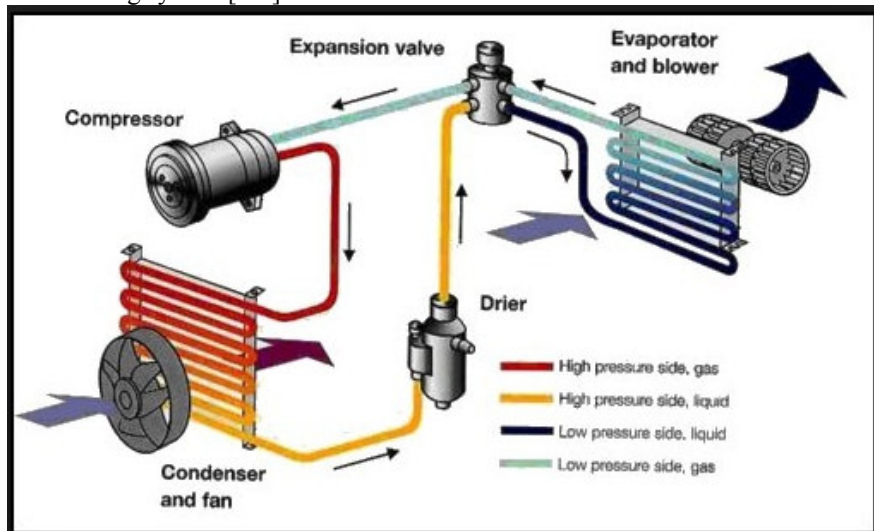

Figure 2: Automobile air-conditioning system construction

Fuel consumption when using AC in cars

Fig.3 shows the fuel mileage (mpg) when using AC system by small, medium, and large car as a function of COP.

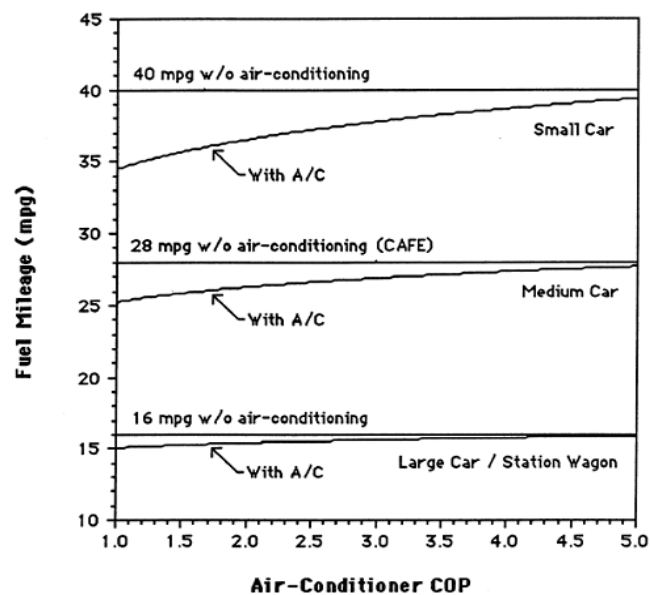

Figure 3: Effect of AC-COP on a fuel mileage.

Solar air-conditioning system of automobiles

The suggested solar air-conditioning system for vehicles are shown in figure 4 and 5.

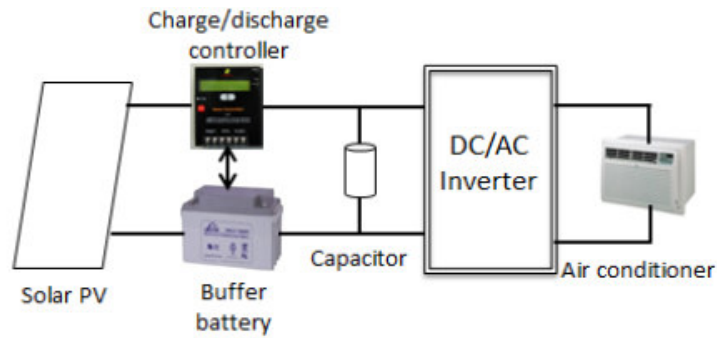

Figure 4: solar air-conditioning system of vehicles

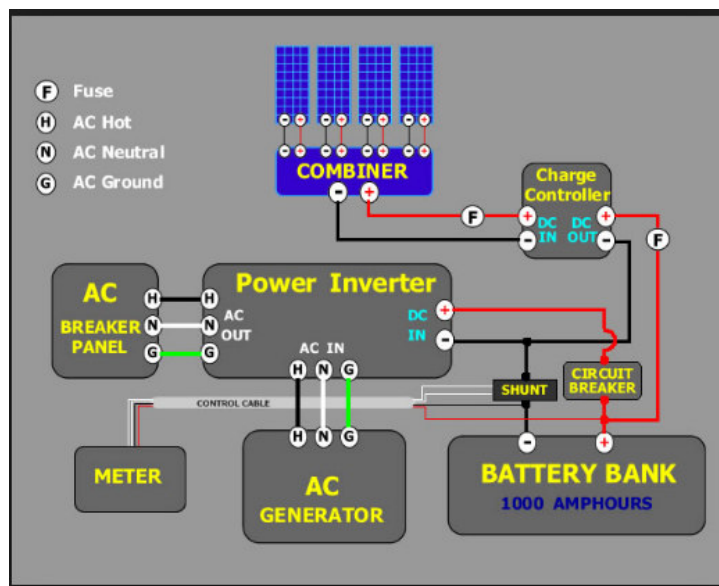

Figure 5: Solar air-conditioning system details

Design of solar air-conditioning system for automobiles

Compared with other air conditioning (A/C) systems, automotive A/C systems have some significant characteristics. Automotive A/C systems present challenges not normally encountered in stationary A/C systems, such as those used in building A/C systems. [8,9]

Case study: Calculation for cooling load required for some given automobile

Fig. 6 shows the Heat transfer processes in automobiles which will be taken into consideration during the calculation of the AC load.

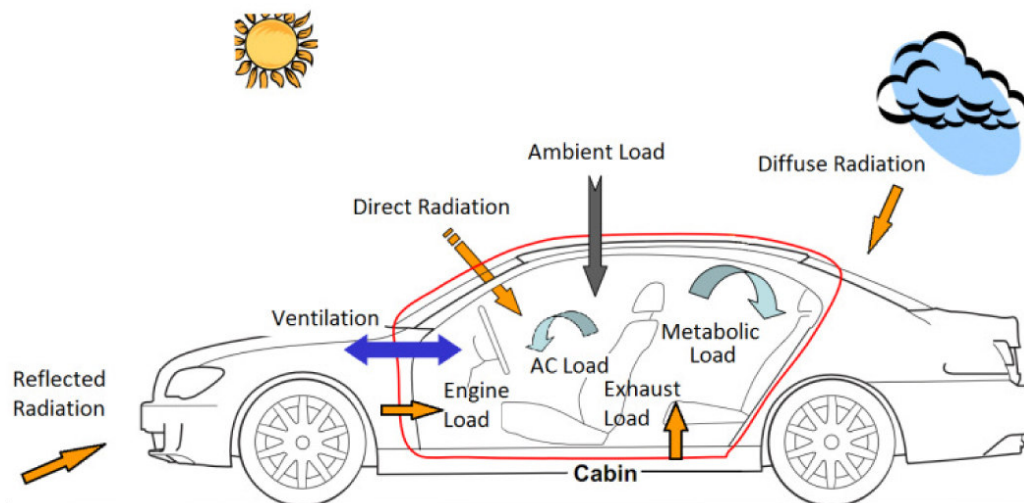

Figure 6: Heat transfer processes in automobiles

Calculating Data

The studied case is an automobile with 5 passengers, the time is 13 pm in July 2016, in Amman-Jordan, the ambient temperature is about 34 C, the comfort temperature needed is 23 C.

The following figure (Fig.7) is used to calculate the AC load depending on the transmissivity in Amman (which is very low about 0.2)

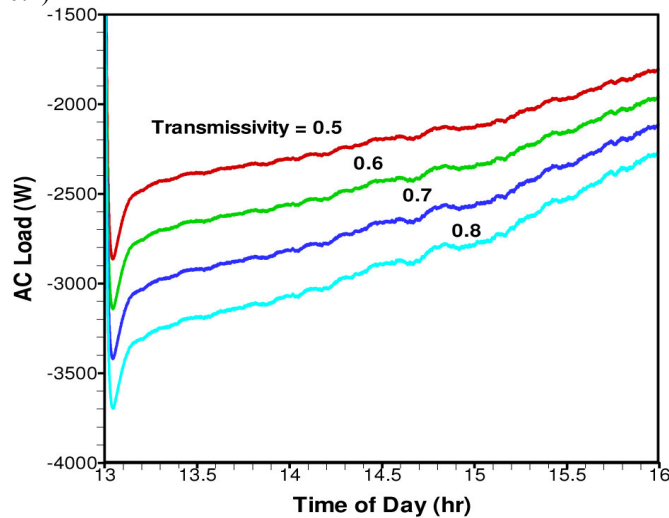

Figure 7: AC Load (W) versus time of the day and transmissivity.

AC load calculation

AC load is used to maintain the comfort in driving condition. Various thermal loads estimations in vehicle cabins can be an assessment of the dynamic changes to the AC loads that occur in the severe condition. **The total cooling load on any automobile is given as:**

$$Q_{AC} = -(Q_{Met} + Q_{Dir} + Q_{Dif} + Q_{Ref} + Q_{Amb} + Q_{Exh} + Q_{Eng} + Q_{Ven}) - \frac{(m_a c_a + DTM)(T_i - T_{comf})}{t_c} \quad (1)$$

Here cooling load is calculated just for three main heat sources:

1. Transmission of heat through the car body structure. The main source is the exhaust heat which translated to the passenger cabin of the car. The high temperature of the exhaust gas can contribute to the thermal gain of the cabin through the cabin floor. In this condition, assumed the overall heat transfer coefficient of the surface element was 0 W/m²k.

$$Q_{Exh} = S_{Exh} U (T_{Exh} - T_i) \quad (2)$$

Where U is the overall heat coefficient of the surface element in contact with the exhaust pipe and it should be calculated by Eq. (3) assuming no external convection since the exhaust temperature is measured at the outer side of the bottom surface. S_{Exh} is the surface area exposed to the exhaust pipe temperature and T_{Exh} is the exhaust gas temperature. So Q_T :

$$Q_T = 0.19 \text{ kW}$$

2. Solar heat gain through the wind-screen and side windows . The increasing in the heat indicates that the weather data effect is very important as the change in the ambient temperature affecting the calculation of the external and internal cooling loads. According to these results, the maximum cooling load is above the cooling capacity of the system occurred in high ambient temperature.

$$Q_{Amb} = \sum_{surface} S U (T_s - T_i) \quad (3)$$

Where U is the overall heat transfer coefficient of the surface element. T_s and T_i are the average temperature and average cabin temperature, respectively. U has different components consisting of the inside convection, conduction through the surface, and outside convection, so

$$Q_R = 0.44 \text{ kW}$$

3. Internal heat gains given as: (The assumption in this study was considered taking into account 1 driver and 3 passengers to calculate the heat in the cabin due to human metabolism. To process the GUI program for metabolic load, the weight and height of the driver and passenger were included to obtain the heat result.)

$$Q_{Met} = \sum_{Passenger\ s} M A_{Du} \quad (4)$$

Where M: is the metabolic heat production by the passengers.

QI = 0.50 kW

Total QTOT = 1.13 kW

Using the last figure (23) we can use Total QTOT=1.2 kW.

The COP is used here to compare the solar AC system for the studied automobile with the traditional AC systems.

$$COP = \frac{Desired\ output}{Input\ power} \quad (5)$$

If we assume that the acceptable solar COP is 2.52 then the input power is $P_{in}=0.6kW$, If we assume 3 hours of working a day and 6 hours sun light /day then Work hours /day = $600 \times 3=1800$ W.hr/day Total load capacity=300 W If the available panels of photovoltaic cells are of 300 W, then the number of panels needed= 1 panel.

2. Results, Discussion and Conclusions

The following table (Table 1) shows a summary of the results of calculation in chapter three

Table 1 summary of calculations

Quantity	Value
Output power	1200 watts
Input power	600 watts
Number of solar panels needed	1 panel
COP	2.52

Figure 8 shows a comparison between the traditional AC automobiles systems and solar one depending on their COP. Referring to fig. 16 and table 1.

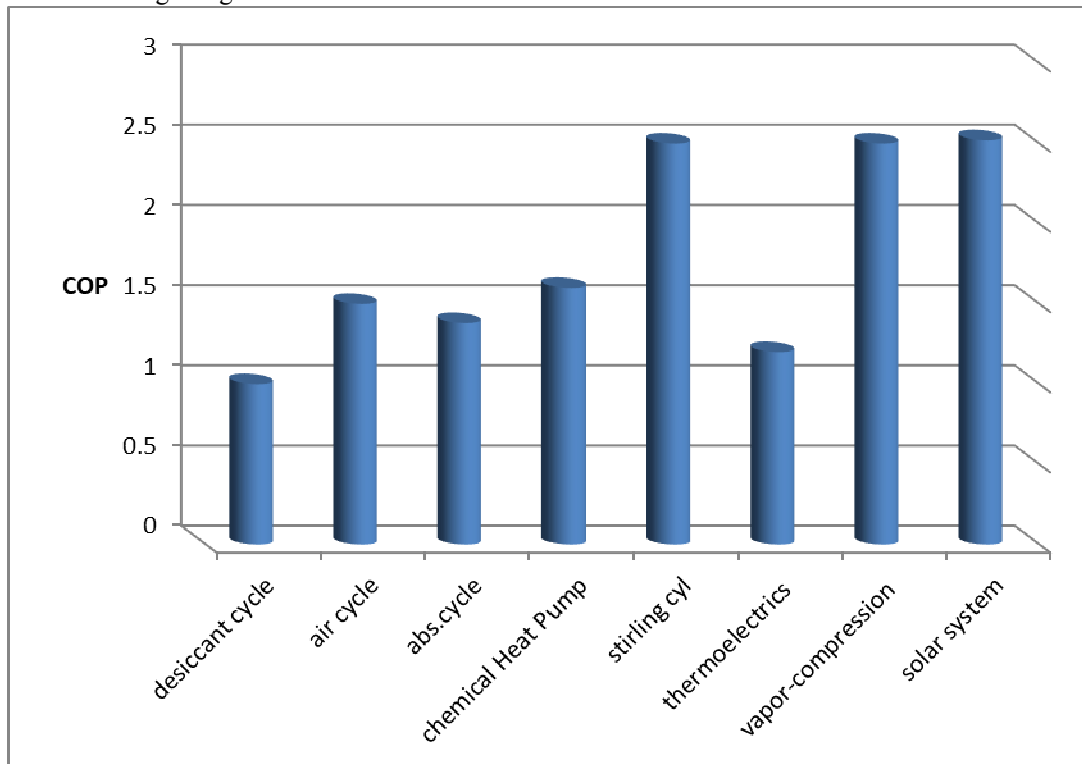

Figure 8: COP for different automobiles AC systems.

The figure shows that the solar system performance is good comparing with the other automobiles AC systems, one can say that COP of solar AC system is equal or close to some other AC technologies used in cars. The other parameter should be taken into consideration is the fuel consumption. Solar fuel consumption for solar systems can be considered as zero, so compared by other systems which have considerable amounts of fuel consumption as shown in fig. 4. Then the solar AC automobiles system performance and efficiency is better than other AC systems.

3. Conclusions

Many technologies are used in AC automobiles systems; such AC systems increase fuel consumptions during operation. The objective of this paper is to construct an AC system completely depending on solar energy. It is found that COP of solar AC automobiles is better than other traditional AC systems. No fuel consumption by using solar AC systems in automobiles. It is found that one panel of photovoltaic cells is required to offer the required power needed to make AC for the studied automobile.

References

- [1] Huang, B.J., Lin, T.H., Chen, Y.T., Hsu, P.C., Lim K. Solar PV-driven air conditioner. EuroSun 2014, International Conference on Solar Energy and Buildings. September 16-19, 2014 . Aix-les-Bains, France.
- [2] Huang, B.J., Hsu, P.C., Wu, M.S., Ho, P.Y.. System dynamic model and charging control of lead-acid battery for stand-alone solar PV system. Solar Energy 84, 822–830, 2010.
- [3] Huang, B.J., Sun, F.S. and Ho, R.W., Near-Maximum-Power-Point- Operation Design of Photovoltaic Power Generation System. Solar Energy 80(8),1003-1020, 2006.
- [4] R.K. Shah, 2006, Automotive Air-Conditioning Systems – Historical Developments, the State Of Technology and Future Trends, “Proceedings of the 3rd BSME-ASME International Conference on Thermal Engineering, 20-22 December 2006, Dhaka, Bangladesh”.
- [5] Md Shahid Imam, Dr.M.Shameer Basha, Dr.Md.Azizuddin, Dr. K.Vijaya Kumar Reddy, 2013, DESIGN OF AIR CONDITIONING SYSTEM IN AUTOMOBILE, International Journal of Innovative Research in Science, Engineering and Technology.
- [6] B. Multerer and R. L. Burton, 1991, Alternative Technologies for Automobile Air Conditioning, Air Conditioning and Refrigeration Center University of Illinois Mechanical & Industrial Engineering Dept. 1206 West Green Street Urbana, IL 61801.
- [7] Mohammad Ali Fayazbakhsh and Majid Bahrami, 2013, Comprehensive Modeling of Vehicle Air Conditioning Loads Using Heat Balance Method, 2013 SAE International.
- [8] Bin-Juine Huang¹, J.K. Guan², D.F. Hou³, Y.H. Chuang⁴, Y.Y. Hsieh⁵, K.Li⁶, K.Y. Lee, 2015, Design of a Novel Solar Air Conditioning System for Electric Vehicles, The 14th IFToMM World Congress, Taipei, Taiwan, October 25-30, 2015.
- [9] Khaled S. Al Qdah, 2015, Performance of Solar-Powered Air Conditioning System under AlMadinah AlMunawwarah Climatic Conditions, Smart Grid and Renewable Energy, 2015, 6, 209-219.
- [10] D. Clodic, S. Barrault, 1990 to 2010 Refrigerants Inventories in EU, 2011.