

# Wind and Solar Cell-Based Distribution System for Different Load Variations Using Fuzzy Logic Controller

P Trimurtulu<sup>1\*</sup> K Bhaskara Rao<sup>2</sup>

1.M Tech, Swamy Vivekananda engineering college, bobbili, vijayanagaram

2.Assistant Professor, Peking Swamy Vivekananda engineering college, bobbili, vijayanagaram

## Abstract

The proposed system presents power-control strategies of a grid-connected hybrid generation system with versatile power transfer. This hybrid system allows maximum utilization of freely available renewable energy sources like wind and photovoltaic energies. For this, an adaptive MPPT algorithm along with standard perturb and observe method will be used for the system. Also, this configuration allows the two sources to supply the load separately or simultaneously depending on the availability of the energy sources. The turbine rotor speed is the main determinant of mechanical output from wind energy and Solar cell operating voltage in the case of output power from solar energy. Permanent Magnet Synchronous Generator is coupled with wind turbine for attaining wind energy conversion system. The inverter converts the DC output from non-conventional energy into useful AC power for the connected load. This hybrid system operates under normal conditions which include normal room temperature in the case of solar energy and normal wind speed at plain area in the case of wind energy. A fuzzy based PWM system will be designed to reduce the harmonic ripples. The simulation results are presented to illustrate the operating principle, feasibility and reliability of this proposed system.

**Keywords:** smart grid, solar cell, fuzzy logic controller

## 1. Introduction

Solar energy is present throughout the day but the solar irradiation levels vary due to sun intensity and unpredictable shadows cast by clouds, birds, trees, etc. The common inherent drawback of wind and photovoltaic systems are their intermittent natures that make them unreliable. However, by combining these two intermittent sources and by incorporating maximum power point tracking (MPPT) algorithms, the system's power transfer efficiency and reliability can be improved significantly. The integration of renewable energy sources and energy-storage systems has been one of the new trends in power-electronic technology. The increasing number of renewable energy sources and distributed generators requires new strategies for their operations in order to maintain or improve the power-supply stability and quality. Combining multiple renewable resources via a common dc bus of a power converter has been prevalent because of convenience in integrated monitoring and control and consistency in the structure of controllers as compared with a common ac type. Dynamic performance of a wind and solar system is analyzed. A wind turbine system model was developed and compared with a real system. Several methodologies for optimal design or unit sizing.

Most applications are for stand-alone operation, where the main control target is to balance local loads. A few grid-connected systems consider the grid as just a back-up means to use when there is insufficient supply from renewable sources. They are originally designed to meet local load demands with a loss of power-supply probability of a specific period. Such hybrid systems, focusing on providing sustainable power to their loads, do not care much about the quality or flexibility of power delivered to the grid. From the perspective of utility, however, a hybrid system with less fluctuating power injection or with the capability of flexibly regulating its power is more desirable. In addition, users will prefer a system that can provide multiple options for power transfer since it will be favorable in system operation and management. Control strategies of such a hybrid system should be quite different from those of conventional systems.

This project addresses dynamic modeling and control of a grid-connected wind-PV-battery hybrid system with versatile power transfer. The hybrid system, unlike conventional systems, considers the stability and dispatch-ability of its power injection into the grid. The hybrid system can operate in three different modes, which include normal operation without use of battery, dispatch operation, and averaging operation.

In order to effectively achieve such modes of operation, two modified techniques are applied; a modified hysteresis control strategy for a battery charger/discharger and a power averaging technique using a low-pass filter. The concept and principle of the hybrid system and its supervisory control are described. Classical techniques of maximum power tracking are applied in PV array and wind-turbine control. Dynamic modeling and simulations were based on Power System Computer Aided Design/Electromagnetic Transients Program for DC (PSCAD/EMTDC), power-system transient-analysis software. The program was based on Dommel's algorithm, specifically developed for the simulation of high-voltage direct current systems and efficient for the transient simulation of power system under power-electronic control.

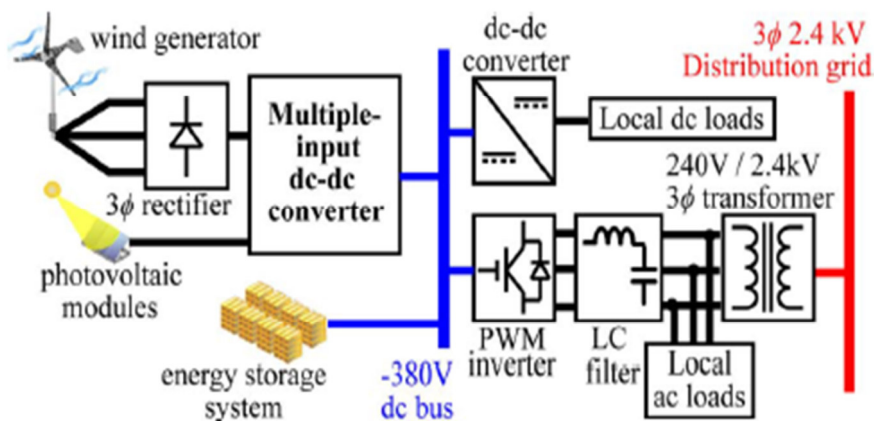

Figure 1. smart grid circuit

## 2. SOLAR CELL

A solar cell is a solid state device that converts the energy of sunlight directly into electricity by the photovoltaic effect. Assemblies of cells are used to make solar modules, also known as solar panels. The energy generated from these solar modules, referred to as solar power, is an example of solar energy.

The origin of the PV potential is the difference in the chemical potential, called the Fermi level, of the electrons in the two isolated materials. When they are joined, the junction approaches a new thermodynamic equilibrium. Such equilibrium can be achieved only when the Fermi level is equal in the two materials. This occurs by the flow of electrons from one material to the other until a voltage difference is established between them, which have a potential just equal to the initial difference of the Fermi level. This potential drives the photocurrent in the PV circuit.

Photovoltaics is the field of technology and research related to the practical application of photovoltaic cells in producing electricity from light, though it is often used specifically to refer to the generation of electricity from sunlight. Cells are described as photovoltaic cells when the light source is not necessarily sunlight. These are used for detecting light or other electromagnetic radiation near the visible range, for example infrared detectors), or measurement of light intensity.

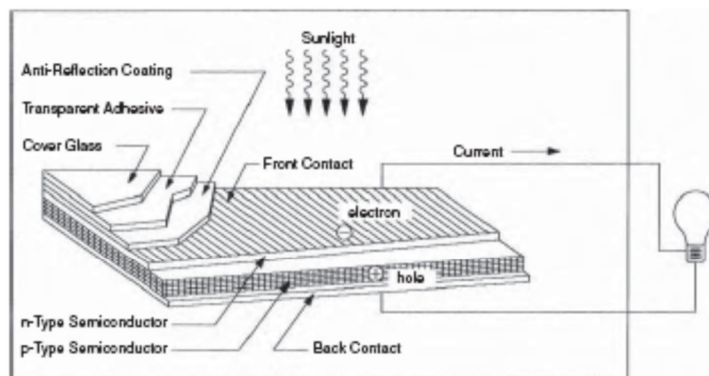

Figure 2: Basic construction of PV cell

The diagram above illustrates the operation of a basic photovoltaic cell, also called a solar cell. Solar cells are made of the same kinds of semiconductor materials used in microelectronics, such as silicon (melted sand) or cadmium telluride. For solar cells, a thin semiconductor wafer is specially treated to form an electric field, positive on one side and negative on the other. When light energy strikes the solar cell, electrons are knocked loose from the atoms in the semiconductor material. If electrical conductors are attached to the positive and negative sides, forming an electrical circuit, the electrons can be captured in the form of an electric current. This electricity can then be used to power a load, such as a light or a tool. Each PV cell converts about 5 to 15 percent of the sunlight that hits it into electrical current. Photovoltaic cells are modular. That is, one can be used to make a very small amount of electricity, or many can be used together to make a large amount of electricity.

## 3. Power from the Wind:

Kinetic energy from the wind is used to turn the generator inside the wind turbine to produce electricity. There are several factors that contribute to the efficiency of the wind turbine in extracting the power from the wind.

Firstly, the wind speed is one of the important factors in determining how much power can be extracted from the wind. This is because the power produced from the wind turbine is a function of the cubed of the wind speed. Thus, the wind speed if doubled, the power produced will be increased by eight times the original power. Then, location of the wind farm plays an important role in order for the wind turbine to extract the most available power from the wind.

The next important factor of the wind turbine is the rotor blade. The rotor blades length of the wind turbine is one of the important aspects of the wind turbine since the power produced from the wind is also proportional to the swept area of the rotor blades i.e. the square of the diameter of the swept area.

Hence, by doubling the diameter of the swept area, the power produced will be four fold increased. It is required for the rotor blades to be strong and light and durable. As the blade length increases, these qualities of the rotor blades become more elusive. But with the recent advances in fiberglass and carbon-fiber technology, the production of lightweight and strong rotor blades between 20 to 30 meters long is possible. Wind turbines with the size of these rotor blades are capable to produce up to 1 megawatt of power.

The relationship between the power produced by the wind source and the velocity of the wind and the rotor blades swept diameter is shown below.

$$P_{\text{wind}} = \frac{\pi}{8} d D^2 v_{\text{wind}}^3 \quad (1)$$

The derivation to this formula can be looked up in [2]. It should be noted that some books derived the formula in terms of the swept area of the rotor blades ( $A$ ) and the air density is denoted as  $\delta$ .

Thus, in selecting wind turbine available in the market, the best and efficient wind turbine is the one that can make the best use of the available kinetic energy of the wind.

#### 4. Energy Storage:

Electricity is more versatile in use than other types of power, because it is a highly ordered form of energy that can be converted efficiently into other forms. For example, it can be converted into mechanical form with efficiency near 100% or into heat with 100% efficiency. Heat energy, on the other hand, cannot be converted into electricity with such high efficiency, because it is a disordered form of energy in atoms. For this reason, the overall thermal-to-electrical conversion efficiency of a typical fossil thermal power plant is less than 50%.

Disadvantage of electricity is that it cannot be easily stored on a large scale. Almost all electric energy used today is consumed as it is generated. This poses no hardship in conventional power plants, in which fuel consumption is continuously varied with the load requirement. Wind and photovoltaic's (PVs), both being intermittent sources of power, cannot meet the load demand at all times, 24 h a day, 365 d a year.

The present and future energy storage technologies that may be considered for stand-alone wind or PV power systems fall into the following broad categories:

- Electrochemical battery
- Flywheel
- Compressed air
- Superconducting coil

The battery stores energy in an electrochemical form and is the most widely used device for energy storage in a variety of applications. There are two basic types of electrochemical batteries:

The *primary battery*, which converts chemical energy into electric energy. The electrochemical reaction in a primary battery is nonreversible, and the battery is discarded after a full discharge. For this reason, it finds applications where a high energy density for one-time use is required.

The *secondary battery*, which is also known as the *rechargeable battery*. The electrochemical reaction in the secondary battery is reversible. After a discharge, it can be recharged by injecting a direct current from an external source. This type of battery converts chemical energy into electric energy. The internal construction of a typical electrochemical cell is shown in Figure. It has positive and negative electrode plates with insulating separators and a chemical electrolyte in between. The two groups of electrode plates are connected to two external terminals mounted on the casing. The cell stores electrochemical energy at a low electrical potential, typically a few volts. The cell capacity, denoted by  $C$ , is measured in ampere-hours (Ah), meaning it can deliver  $C$  A for one hour or  $C/n$  A for  $n$  hours.

The battery is made of numerous electrochemical cells connected in a series-parallel combination to obtain the desired battery voltage and current. The higher the battery voltage, the higher the number of cells required in series. The battery rating is stated in terms of the average voltage during discharge and the ampere-hour capacity it can deliver before the voltage drops below the specified limit. The product of the voltage and ampere-hour forms the watt-hour (Wh) energy rating the battery can deliver to a load from the fully charged condition. The battery charge and discharge rates are stated in units of its capacity in Ah. For example, charging a 100-Ah

battery at  $C/10$  rate means charging at  $100/10 = 10$  A. Discharging that battery at  $C/2$  rate means drawing  $100/2 = 50$  A, at which rate the battery will be fully discharged in 2 h. The state of charge (SOC) of the battery at any time is defined as the following:

$$SOC = \frac{\text{Ah Capacity remaining in the battery}}{\text{Rapid Ah capacity}}$$

**TABLE.1 Average Cell Voltage during Discharge in Various Rechargeable Batteries**

Electrochemistry	Cell Volts	Remark
Lead-acid	2.0	Least-cost technology
Nickel-cadmium	1.2	Exhibits memory effect
Nickel-metal hydride	1.2	Temperature sensitive
Lithium-ion	3.6	Safe, contains no metallic lithium
Lithium-polymer	3.0	Contains metallic lithium
Zinc-air	1.2	Requires good air management to limit self-discharge rate

### 5. SIMULATION DESIGN

We can visualize the system by viewing signals with the displays and scopes provided in Simulink software. Alternatively, we can build our own custom displays using MATLAB® visualization and GUI development tools. We can also log signals for post-processing.

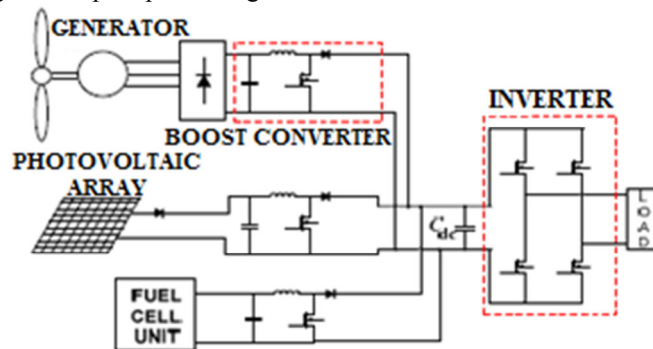

Fig 3 Model Of Proposed Hybrid Circuit

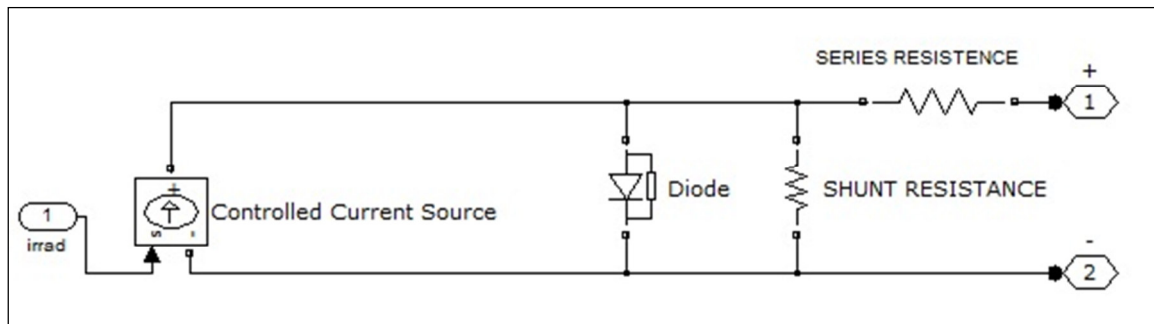

Fig 4 Basic Structure Of PV-Cell

The basic PV cell is built with the current supplied from the solar energy and then it is fed forward with the use of diode. There are two resistances both in shunt and series connection to enhance the working of the PV cell.

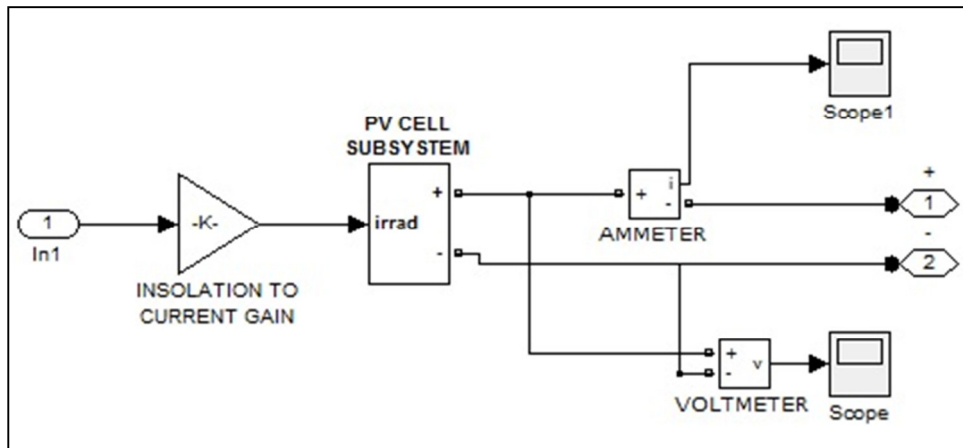

Fig 5 Transition Of Insolation Into Current Gain

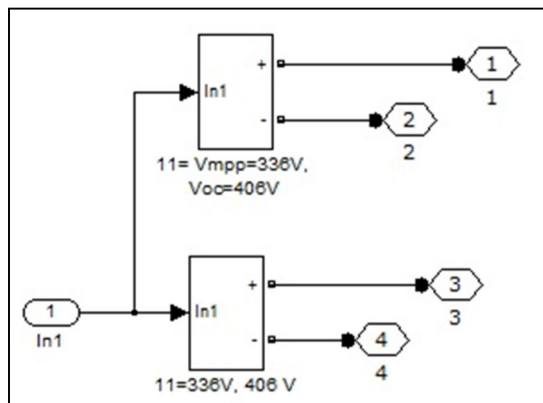

Fig 6 Parallel Connection Of Solar Cell

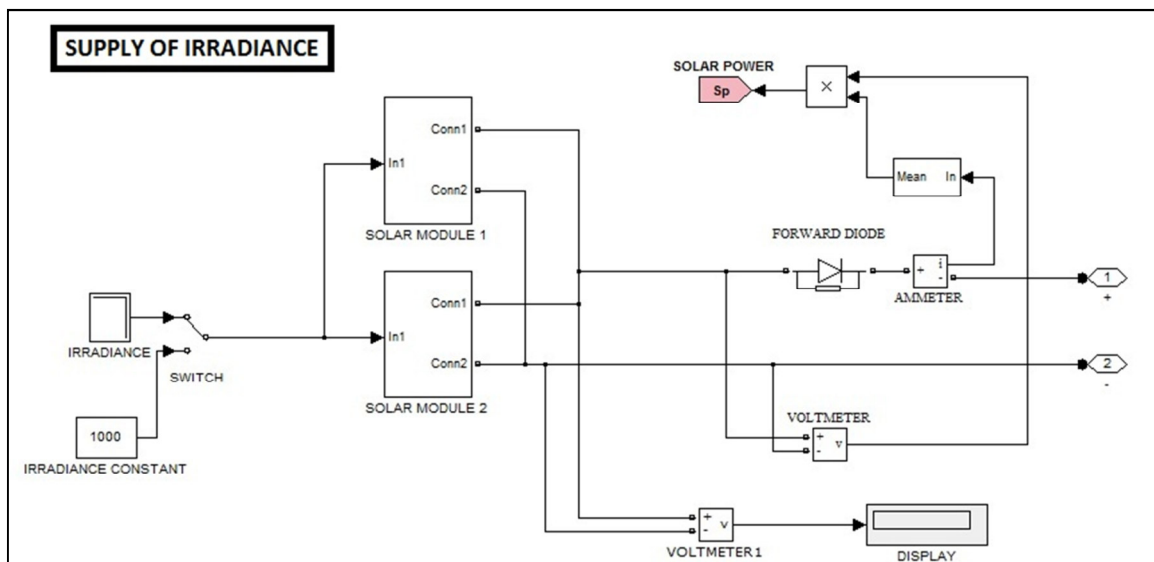

Fig 7 Simulation Model Showing The Utilization Of Irradiance And Solar Modules

There are two modules of PV cells in the designed PV Array. There are two rows of 11 cells in each PV module. The voltage developed at the parallel connection between the parallel connection of the PV modules is measured here with the inclusion of the Display block of simulink.

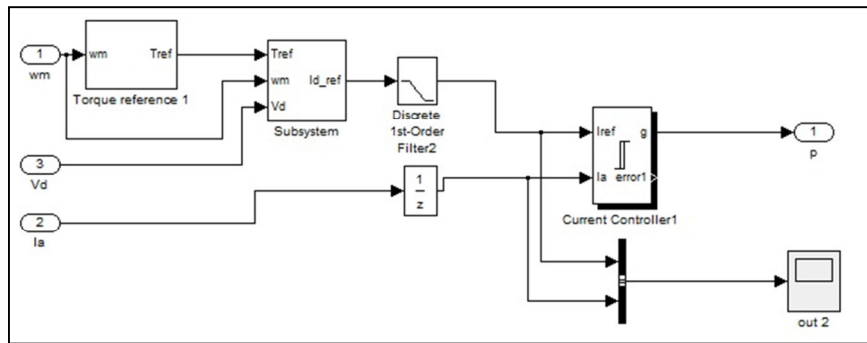

Fig 8 MPPT Attainment for Wind Energy System

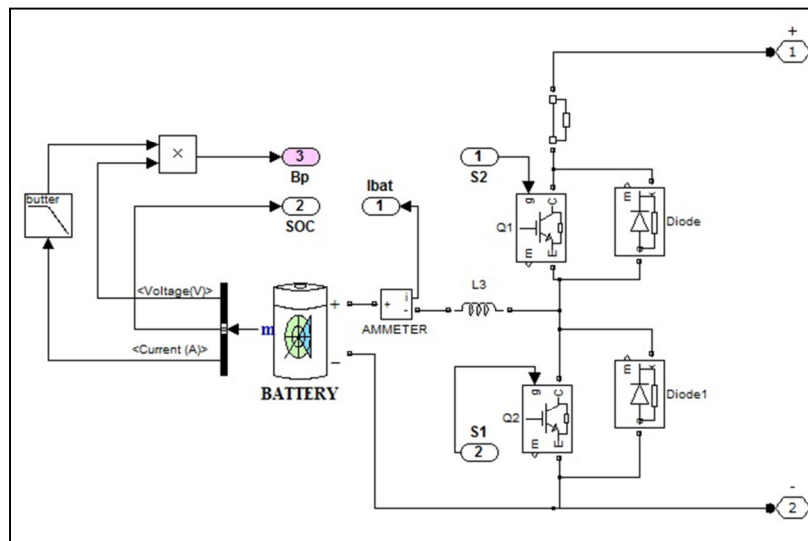

Fig 9 Battery Operation features sufficient supply to load

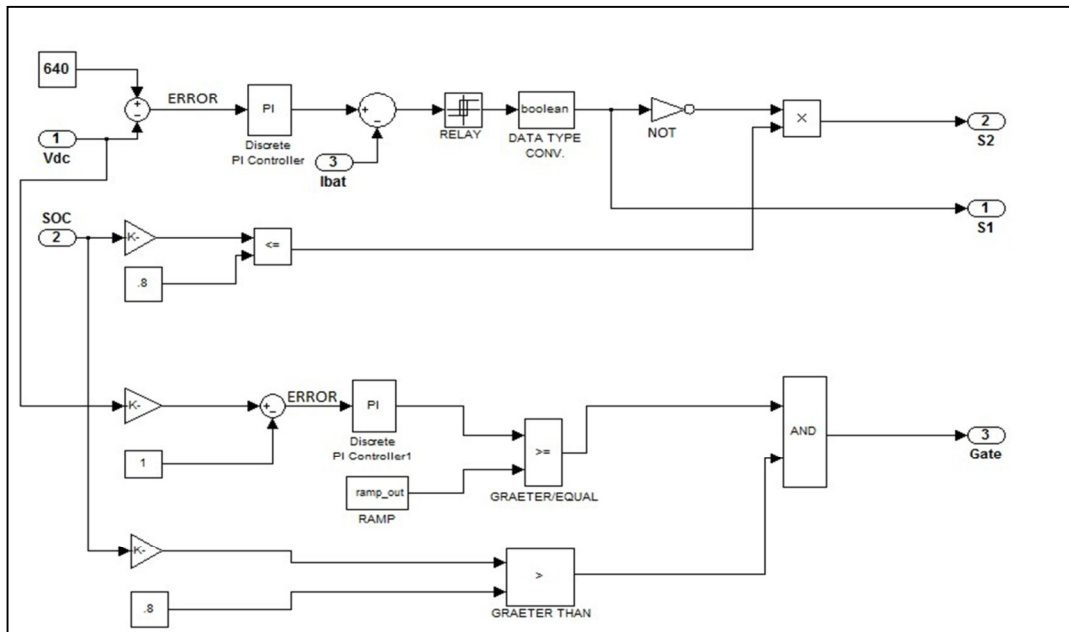

Fig 10 Working Logic of Battery Operation

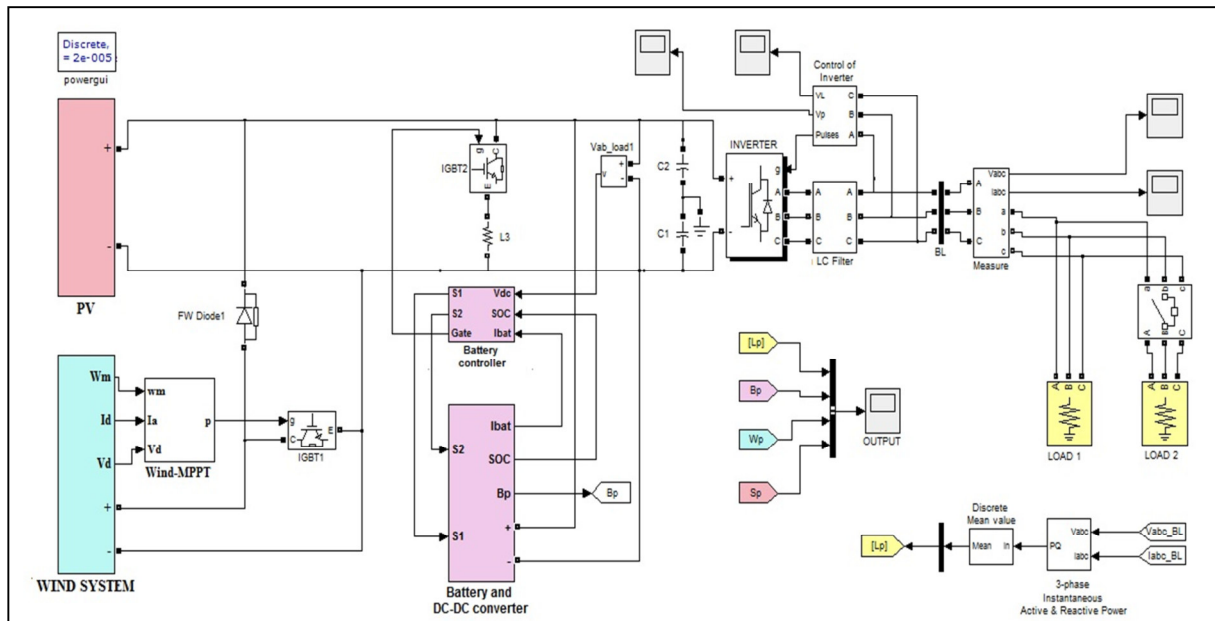

Fig 11 Composite Simulation Model of Proposed Hybrid System

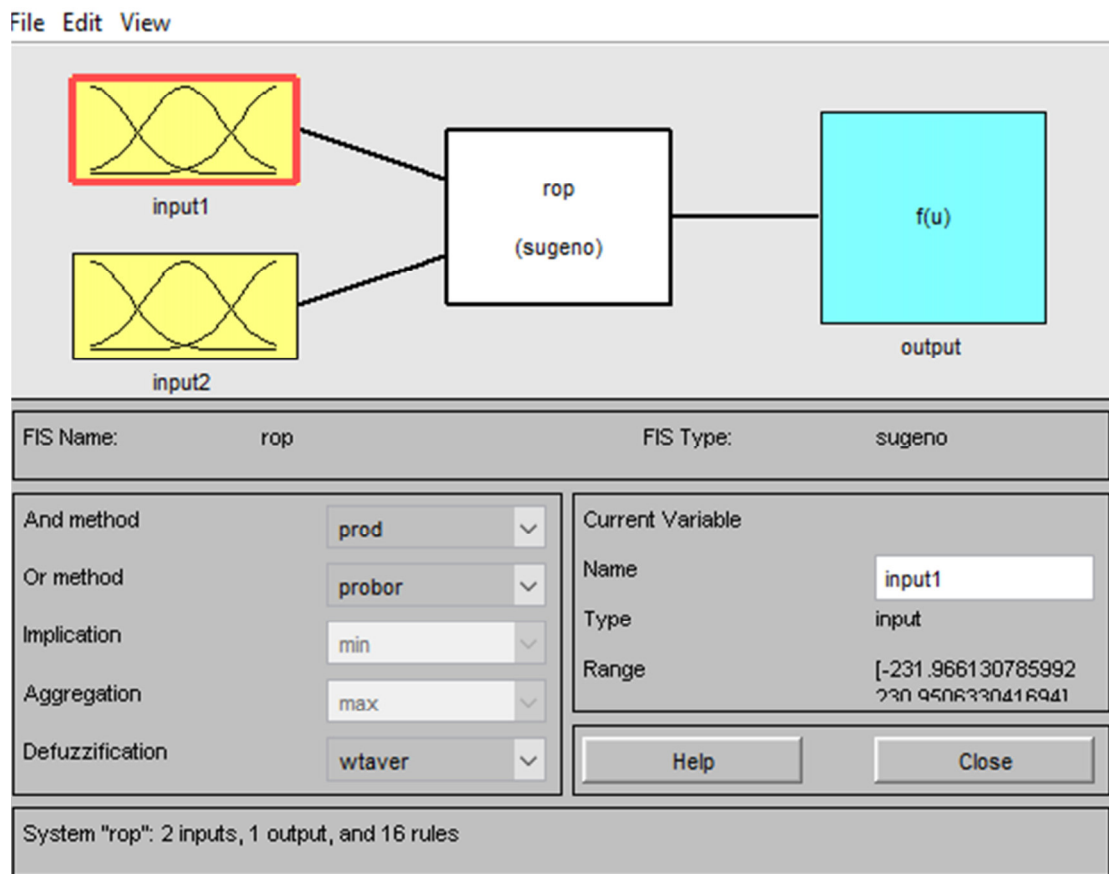

Fig 12 Fuzzy logic controller

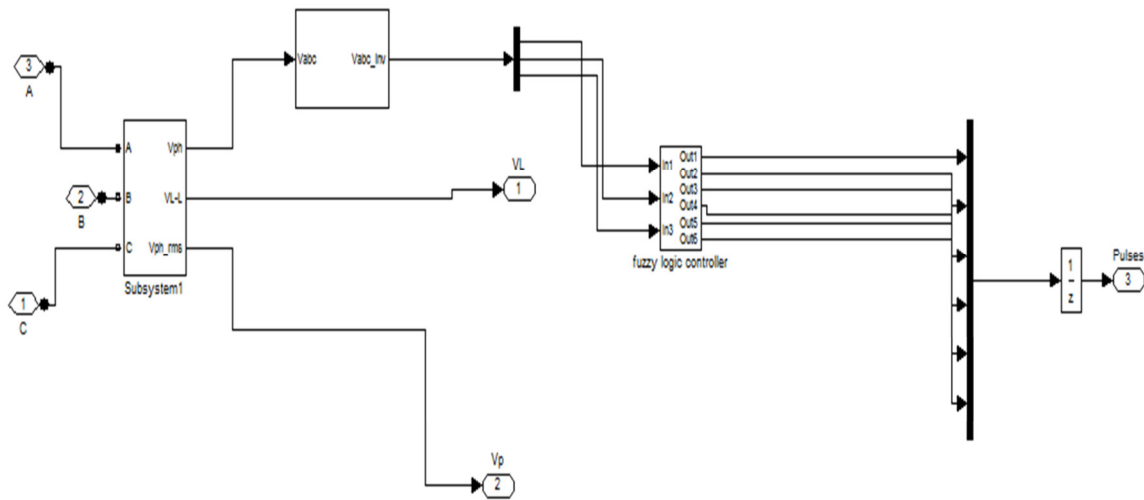

fig 13 Fuzzy logic controller based pwm controller

**6 Simulation results:**

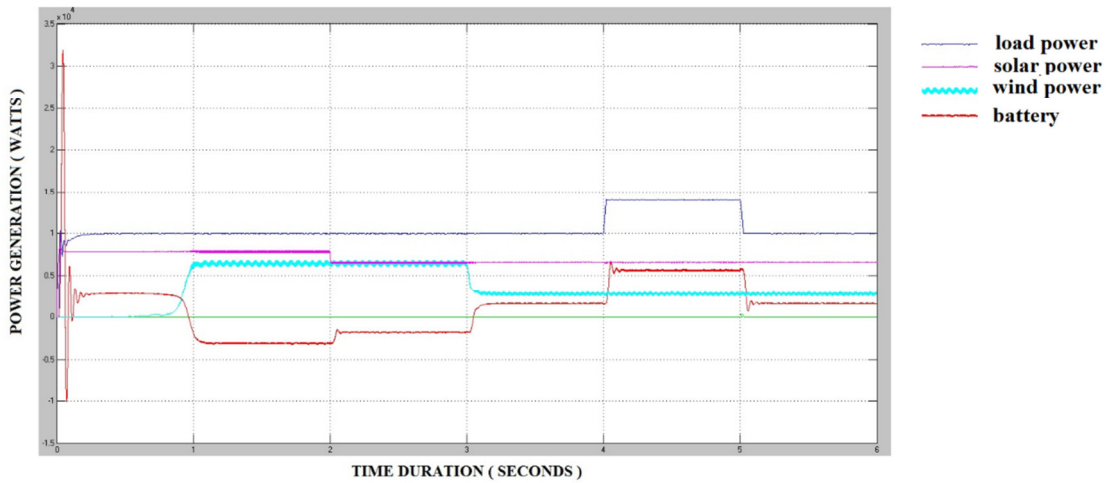

Fig 14 Load Sharing Action Performed by the the Hybrid Energy Energy in BIPV Double Glass Solar Panel

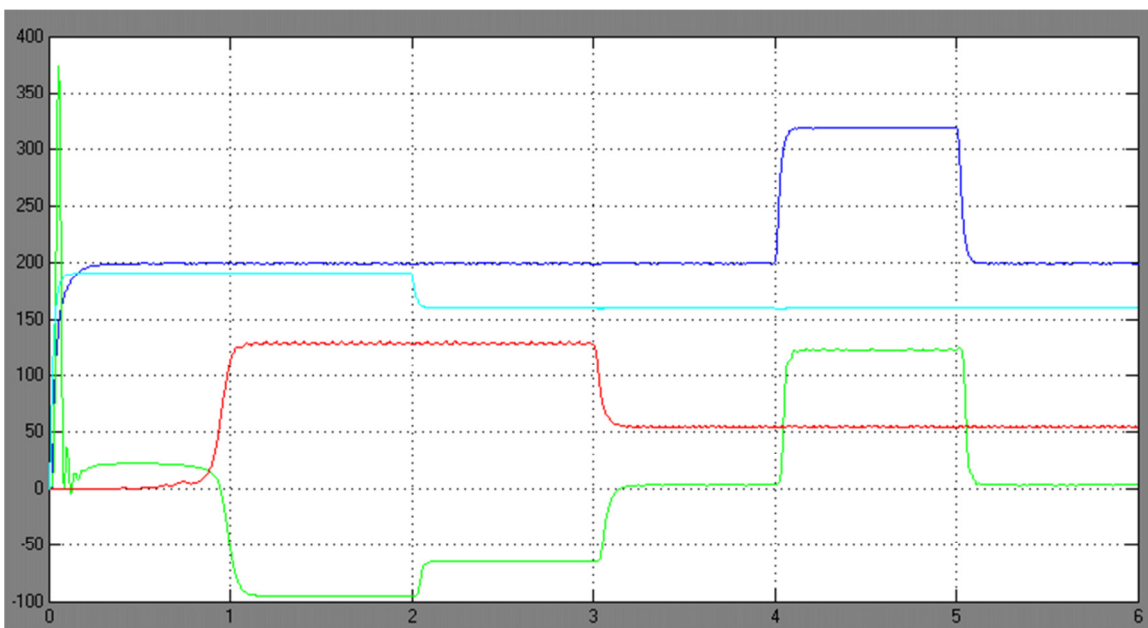

Fig 15 Load Sharing Action Performed by the Hybrid Energy Energy in Polycrystalline Solar Panel TSP 215 with FUZZY controller



## 7. Conclusion

In this paper load demand is met from the combination of PV array, wind turbine and the battery. An inverter is used to convert output from solar & wind systems into AC power output. Circuit Breaker is used to connect an additional load of 5 KW in the given time. This hybrid system is controlled to give maximum output power under all operating conditions to meet the load. Either wind or solar system is supported by the battery to meet the load. Also, simultaneous operation of wind and solar system is supported by battery for the same load. While comparing with PWM controller fuzzy control gives better performance for inverter control. Disturbance due to load change can be reduced by using fuzzy logic controller.

## References

- [1] Joanne Hui\*, Alireza Bakhshai, and Praveen K. Jain, "A Hybrid Wind-Solar Energy System: A New Rectifier Stage Topology", in Applied Power Electronics Conference and Exposition (APEC), 2010 Twenty-Fifth Annual IEEE, pp 156-161, 21-25 Feb. 2010
- [2] S.K. Kim, J.H. Jeon, C.H. Cho, J.B. Ahn, and S.H. Kwon, "Dynamic Modeling and Control of a Grid-Connected Hybrid Generation System with Versatile Power Transfer," IEEE Transactions on Industrial Electronics, vol. 55, pp. 1677-1688, April 2008.
- [3] N. A. Ahmed, M. Miyatake, and A. K. Al-Othman, "Power fluctuations suppression of stand-alone hybrid generation combining solar photovoltaic/wind turbine and fuel cell systems," in Proc. Of Energy Conversion and Management, Vol. 49, pp. 2711-2719, October 2008.
- [4] Y.M. Chen, Y.C. Liu, S.C. Hung, and C.S. Cheng, "Multi-Input Inverter for Grid-Connected Hybrid PV/Wind Power System," IEEE Transactions on Power Electronics, vol. 22, May 2007.
- [5] S. Jain, and V. Agarwal, "An Integrated Hybrid Power Supply for Distributed Generation Applications Fed by Nonconventional Energy Sources," IEEE Transactions on Energy Conversion, vol. 23, June 2008.
- [6] D. Das, R. Esmaili, L. Xu, D. Nichols, "An Optimal Design of a Grid Connected Hybrid Wind/Photovoltaic/Fuel Cell System for Distributed Energy Production," in Proc. IEEE Industrial Electronics Conference, pp. 2499-2504, Nov. 2005.
- [7] dos Reis, F.S., Tan, K. and Islam, S., "Using PFC for harmonic mitigation in wind turbine energy conversion systems" in Proc. of the IECON 2004 Conference, pp. 3100- 3105, Nov. 2004
- [8] R. W. Erickson, "Some Topologies of High Quality Rectifiers" in the Proc. of the First International Conference on Energy, Power, and Motion Control, May 1997.
- [9] D. S. L. Simonetti, J. Sebasti'an, and J. Uceda, "The Discontinuous Conduction Mode Sepic and ' Cuk Power Factor Preregulators: Analysis and Design" IEEE Trans. On Industrial Electronics, vol. 44, no. 5, 1997
- [10] N. Mohan, T. Undeland, and W Robbins, "Power Electronics: Converters, Applications, and Design," John Wiley & Sons, Inc., 2003.
- [11] J. Marques, H. Pinheiro, H. Grundling, J. Pinheiro, and H. Hey, "A Survey on Variable-Speed Wind Turbine System," Proceedings of Brazilian Conference of Electronics of Power, vol. 1, pp. 732-738, 2003.
- [11] F. Lassier and T. G. Ang, "Photovoltaic Engineering Handbook" 1990
- [12] Global Wind Energy Council (GWEC), "Global wind 2008 report," June 2009.