

Matlab /Simulink Based-analysis of Photovoltaic Array Fed Multilevel Boost Converter

Praveen bansal¹

Department of Electrical Engineering, Maulana Azad National Institute of Technology, Bhopal (M.P)
¹Email-pbansal44@rediffmail.com

Abstract

The increasing private sectors are focusing employment of eco friendly renewable/green power technologies like PV Cells, Fuel Cells, Wind turbine to meet the growing power demand. This paper presents the analysis and operation of PV system using Multilevel DC to DC Boost Converter Topology .The DC to DC Multilevel Boost converter is based on one inductor, one switch, 2N-1 diodes and 2N-1 capacitors, for an N_x converters, it is a boost converter able to control and maintain the same voltage in all the N output levels and able to control the input current. The proposed model and their performance are evaluated for varying loads in MATLAB/Simulink environment.

Keywords – PV array , Multilevel boost converter ,Matlab, simulink

1. Introduction

Increased energy utilization and global pollution awareness have made green/renewable power more and more important for stand alone as well as distributed generation. Wind turbines, Photovoltaic and Fuel Cells are different types of green power technologies. Photovoltaic systems have been extensively employed for large power generation around the whole world in recent decades. The conversion of solar energy into electric energy is performed by means of photovoltaic cells.

In order to adapt the output Voltage of the energy supplies/storage systems the medium voltage level, boosting of the DC voltage is required. For large voltage step-up ratios this task is advantageously performed by DC- DC converters[1]. Since the PV array delivers Dc power, it must be inverted to AC and stepped-up to be able to use for household applications as well as for distributed generation and output voltage is regulated desired level. Therefore a suitable Power electronic interface is required between PV array and load, with the capabilities of balance output voltage.

Above task can be achieved by connecting a DC-DC converter with voltage gain to the PV array.The proposed model of renewable energy fed Multilevel Boost converter using Matlab/simulink is given Figure(1).

PROPOSED MATLAB /SIMULINK MODEL OF PV ARRAY FED MULTILEVEL BOOST CONVERTER

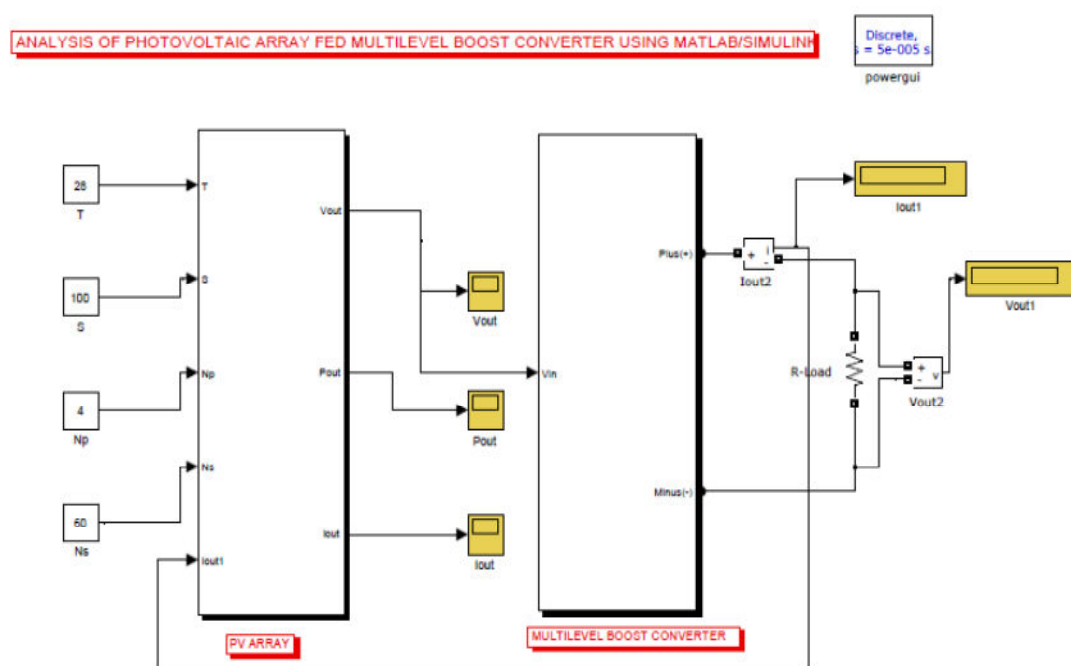

Figure1 .Proposed Multilevel Boost Converter for PV array Application.

Several topologies of switched mode DC-DC converter followed by dc source are proposed and compared based on their performance. A switch mode DC-DC converter is preferred to limit the size and cost of the system. A current fed DC-DC converter is preferred over the voltage fed DC-DC converter as the former requires reduced input filtering. A push pull DC-DC converter is selected with voltage gain to reduce the switches conduction losses. However, its use is restricted to own ad medium power applications. Full bridge topology is preferred for high power applications as push-pull topologies have a serious problem of centre tap termination, which tends to cause saturation of the transformer at high power levels, though a full bridge requires more switches of half rating, which is more economical & efficient.

All these topologies discussed above, uses multiple stage conversion to deal with the above mentioned challenges, which results in large component count, therefore poor reliability, additional cost, and low efficiency. In addition to this, energy storage devices such as battery and ultra capacitors are also needed at various stages either to supply auxiliaries or to improve the slow transient's response of the PV array.

2. MODELLING OF PV ARRAY

The building blocks of PV array are the solar cell, which is basically a p-n junction that directly converts light energy into electricity, it has a equivalent circuit as shown below in figure....

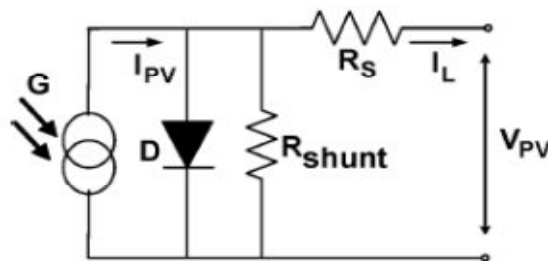

Figure.2 Electrical Circuit of PV Module

The current source I_{pv} represents the cell photo current, R_{shunt} and R_s are used to represent the intrinsic series and shunt resistance of the cell respectively. Usually the value of R_{shunt} is very large and that of R_s is very small, hence they may be neglected to simplify the analysis. PV cells are grouped in larger units called PV modules which are further interconnected in series-parallel configuration to form PV arrays [2]. The PV mathematical model used to simplify our PV array is represented by the equation .

$$I = n_p * I_{ph} - n_p I_{rs} [\exp((qV)/(KTAn_s)) - 1] \dots\dots\dots(1)$$

Where I is the PV array output current, V is the PV array output Voltage, n_s is the number of cells in series and n_p is the number of cells in parallel, q is the charge of an electron, k is the Boltzmann constant, A is the p-n junction ideality factor, T is the cell temperature (K), I_{rs} is the cell reverse saturation current. The factor A in equation determines the cell deviation from the ideal p-n junction characteristics it ranges between 1-5 but for our case $A=2.46$ [3].

The cell reverse saturation current I_{rs} varies with temperature according to the following equation:

$$I_{rs} = I_{rr} \left\{ \frac{T}{T_r} \right\}^3 \exp \left[\left\{ \frac{qE_g}{KA} \right\} \left\{ \frac{1}{T_r} - \frac{1}{T} \right\} \right] \dots\dots\dots(2)$$

The temperature dependence of the energy gap of the semi conductor is given by

$$E_g = E_g(0) - \left\{ \frac{\alpha T^2}{T + \beta} \right\} \dots\dots\dots(3)$$

The photo current I_{ph} depends upon on the solar radiation and cell temperature as follows:

$$I_{ph} = [I_{scr} + K_i(T - T_r)] * (S/100) \dots\dots\dots(4)$$

The Power can be calculated as

$$P = VI = n_p I_{ph} V \left[\left\{ \frac{qV}{KTAn_s} \right\} - 1 \right] \dots\dots\dots(5)$$

2.1 Voltage-Current characteristics of PV Array under a fixed irradiance but varying temp.

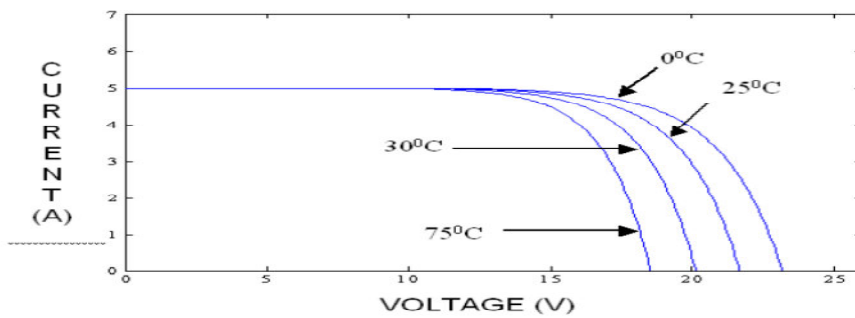

Figure3. VI characteristics of PV Array

2.2 P-V characteristics of a solar array for a fixed temperature but varying irradiance

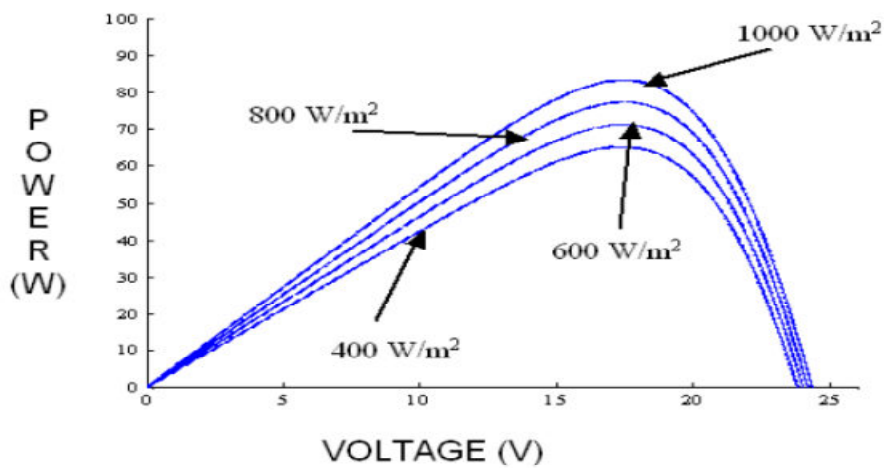

Figure4. PV characteristics of PV Array

2.3 P-V Characteristics of a PV array under a fixed irradiance but varying temperatures

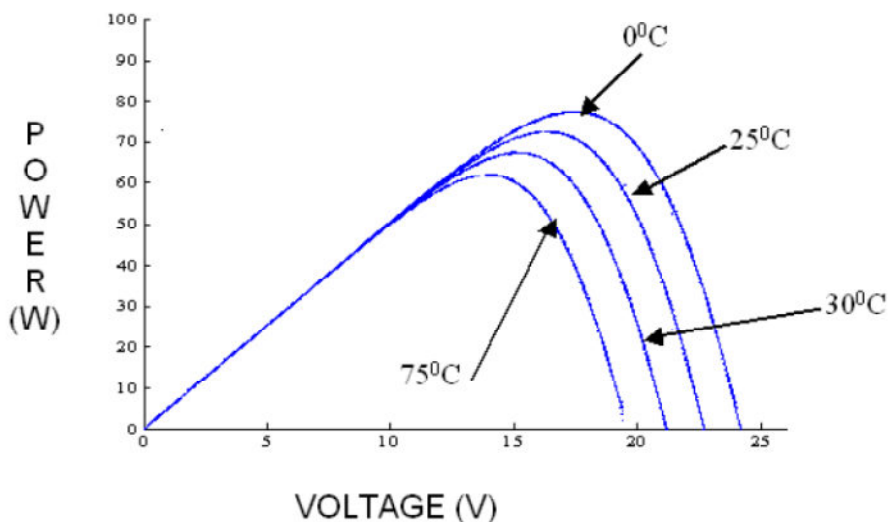

Figure5. PV Characteristics of PV Array

2.4 Simulink model of Photovoltaic array

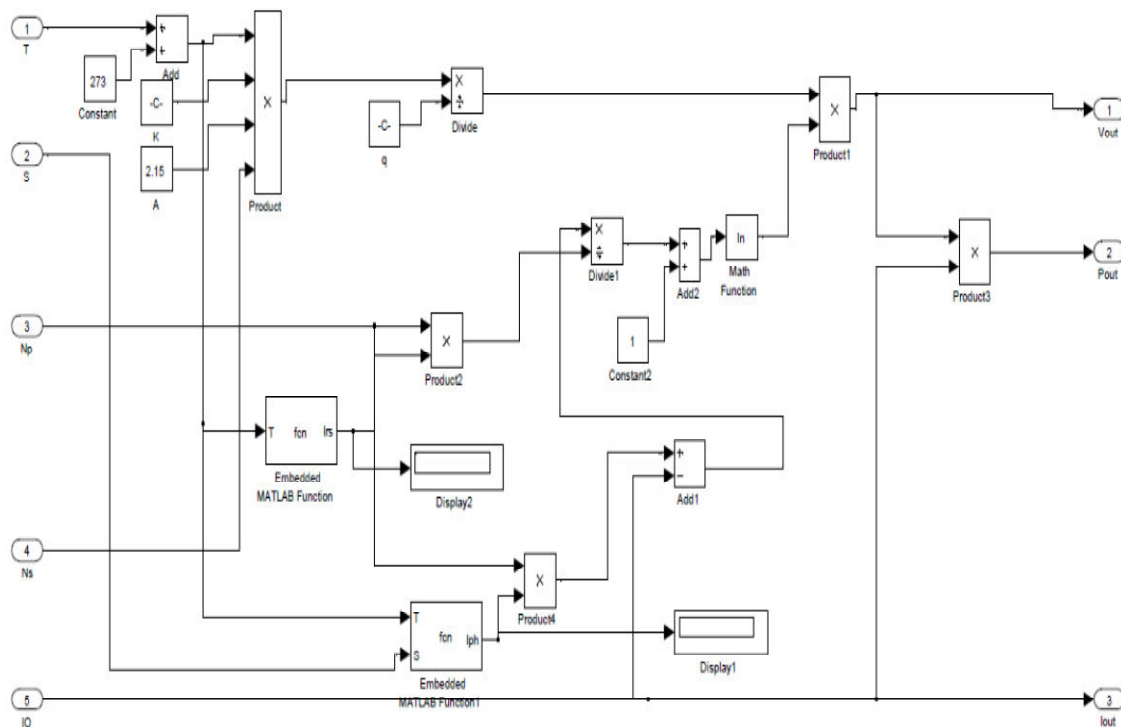

Figure 6. Simulink Model of Photo Voltaic Array

2.5 Parameters Value used in PV Array

Parameters	Values
Np	4
Ns	60
Iscr	3.75 A
Tr1	40 C
Ki	0.00023 A/K
Irr	0.00021 A
K	$1.38065 \cdot 10^{-23}$ J/K
q	$1.6002 \cdot 10^{-19}$ C
A	2.15
Eg(0)	1.66 eV
α	$4.73 \cdot 10^{-4}$ eV/K
β	636 K

3. MODELLING OF DC-DC MULTILEVEL BOOST CONVERTER

Figure.7. shows the multilevel boost converter “MBC”. An Nx MBC is based on one driven switch 2N-1 diodes and 2N-1 capacitors , the number of levels can be extended by adding capacitors and diodes and the main circuit does not need to be modified[4].

The lower part of the converter is the conventional Boost Converter, then the voltage gain also holds for the well know boost converter equations. The difference between the multilevel boost converter and the conventional one is that in the multilevel boost converter the output is V_c ,times N, where N+1 is the converter’s number of levels take into account the zero level. This behavior is achieved thanks to the voltage multiplier in the output of the boost converter which is driven by the switch in the converter.

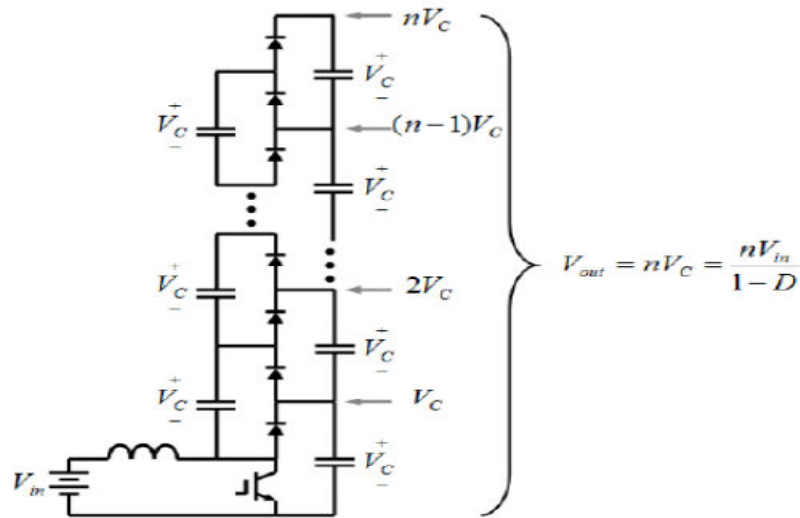

Figure 7. Multilevel DC-DC boost converter for Nx and Nx+1 levels

3.1 TURN ON AND TURN OFF STATES

The multilevel principle of this converter will be explained through a 4x(5 levels) DC-DC boost converter .To explain the multilevel principle explain ,assume that the switch (s) is switching with a duty ratio(d) of 0.5. During the switch-on state , the inductor is connected to Vin voltage. Figure 8a. If C6 voltage is smaller than C7 voltage then C7 clamps C6 voltage through D6 and the switch S. Figure 8b. At the same time if the voltage across C4 +C6 is smaller than the voltage across C5 + C7 , then C5 and C7 clamps the voltage across C4 and C6 through D4 and S. Figure 8c . In a similar C3 , C5 and C7 clamps the voltage across C2 ,C4 and C6 in Figure 8d.

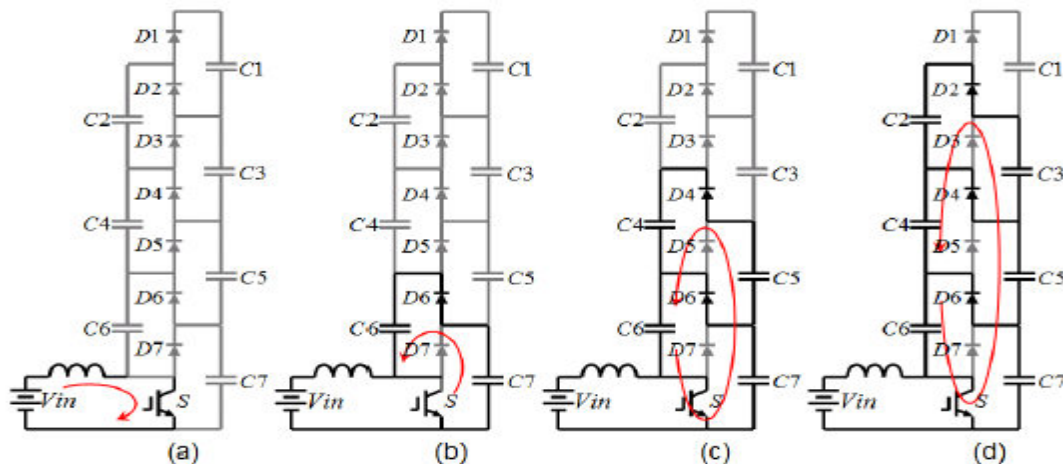

Figure 8. Turn On state of Multilevel Boost Converter

When the switch turns off, the inductor current closes D7 , and switches all diodes , During the switch Off state , the inductor current closes D7 charging C7. Figure 9a. When D7 closes , C6 and the voltage in Vin plus the inductor's voltage clamp the voltage across C5 and C7 through D5 Figure 9b, Similarly the voltage across C3 , C5 and C7 through D3. Finally the voltage across C1 ,C5, C3 and C7. Is clamped by C2 ,C4 , C6, Vin and the inductor voltage in Figure 9c. It is noteworthy that D1, D3 ,D5 and D7 switch in a synchronously way , complemented with D2 , D4, D6 and S.

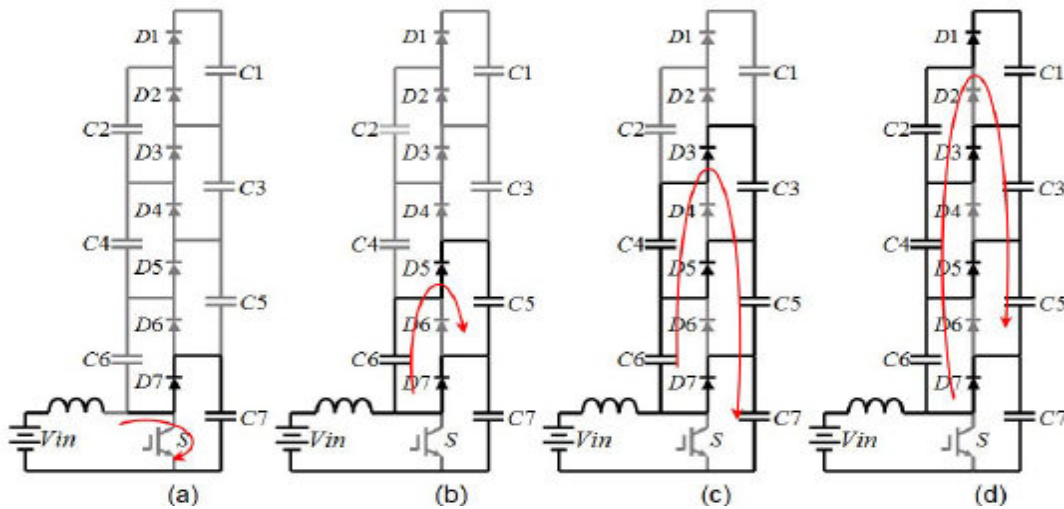

Figure 9. Turn Off state of Multilevel Boost Converter

3.2 DESIGN SPECIFICATION OF MULTILEVEL BOOST CONVERTER

Specification	Values
Input Voltage	20-30 V
Output Voltage	250-320(DC)
Switching Frequency(f)	10 KHz
Duty Cycle (D)	$0.4 < D < 0.8$
Inductance (L1)	20mH
Capacitance	110 μ F
Switch Type	Mosfet

The transfer function of Conventional Boost converter is .

$$V_{out} = V_g \frac{1}{1-D}$$

But in the Multilevel Converter the transfer function is

$$V_{out} = V_g * N \frac{1}{1-D}$$

It is shown from last two equations that the Multilevel Boost converter has a big conversion ratio without extreme duty cycle depending on the level of it[5].

4. SIMULATION RESULTS

The simulink model of the Photovoltaic array fed Multilevel Boost Converter is modeled in Figure.1 using Matlab/simulink environment. The simulation work is carried out for a triangular waveform of 10Khz switching frequency for the Multilevel Boost converter its switching pattern model is shown in figure9.

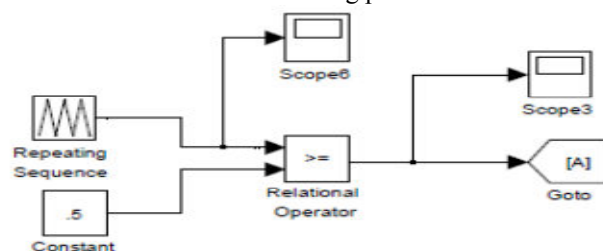

The waveform of switching pulse generation for Mosfet is shown in figure.10 and Figure.11

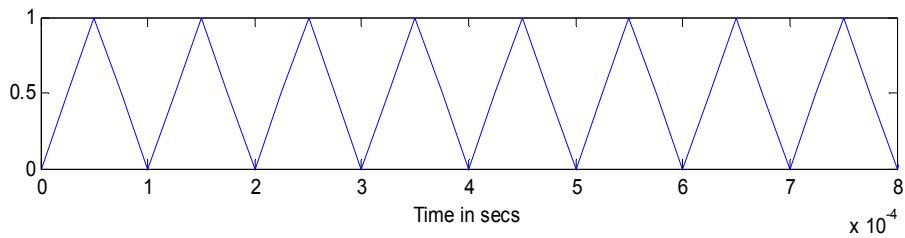

Figure10. Triangular waveform for Switching pulse generation

The Waveform of switching pulse generation is shown in Figure.11

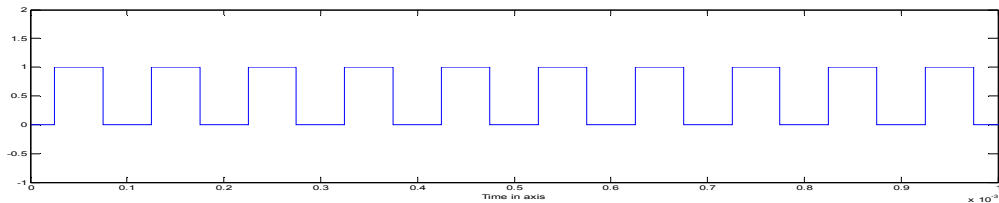

Figure.11 Switching pulse generation

Waveform of Input voltage of Photovoltaic array is shown in Figure.12

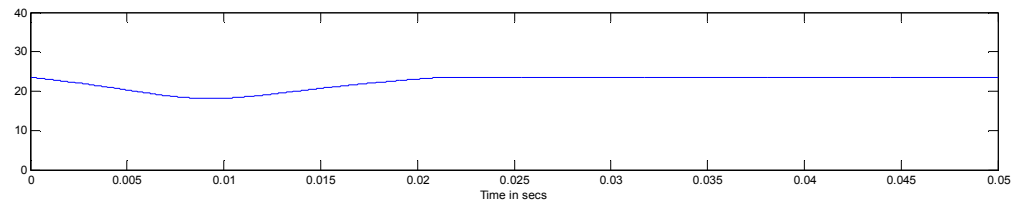

Figure.12 Input voltage

Waveform of Input current of Photovoltaic array is shown in Figure.13

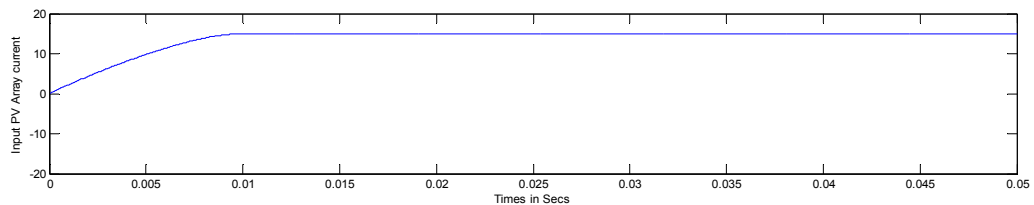

Figure.13 Input current

Waveform of Output Voltage is shown in Figure.14

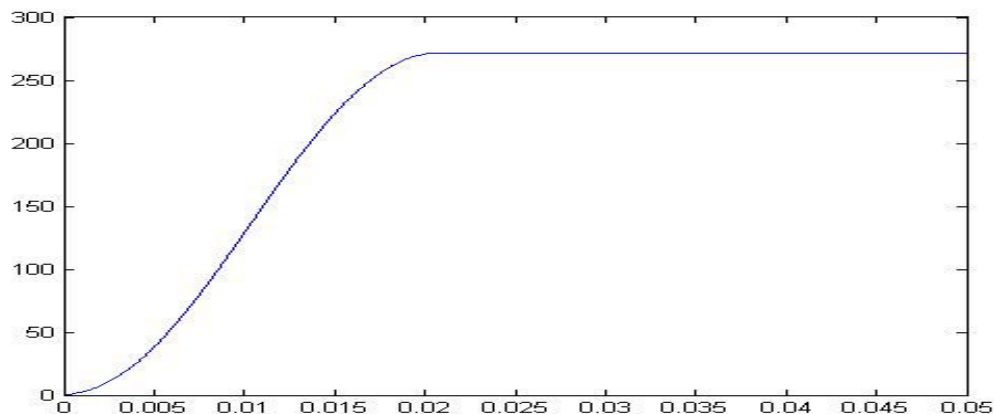

Figure.14 Output voltage

5. CONCLUSION

The open circuit P-V, P-I and I-V curves we obtained from the simulation of the PV array designed in MATLAB environment explains in detail its dependence on the irradiation levels and temperatures. The entire energy conversion system has been designed in MATLAB-SIMULINK environment. The various values of the voltage

and current obtained have been plotted in the open circuit I-V curves of the Photovoltaic array at insolation levels of 100mW/cm² and 80mW/cm². The Voltage and current values lie on the curve showing that the coupling of the PV array with the Multilevel Boost Converter is proper[6]. However the performance of the photovoltaic device depends on the spectral distribution of the solar radiation.

6. REFERENCE

- MAKSIMOVIC D, CUK S:,' Switching Converters with wide Dc conversion range', IEEE Trans. Power Electronics , 2001,6.(1) , pg. No. 151-157.
- I.H Atlas , A.M sharaf ,," A photovoltaic Array Simulation Model for Matlab-simulink GUI Environment ," Proc. of IEEE International Conference on clean Electrical Power ,ICCEP 2007 , Capri, Italy.
- Quan Li and Peter Wolfs ,," A Review of the Single Phase Photovoltaic Module Integrated Converter Topologies With three Different DC link Configurations" IEEE Transactions on Power Electronic , Vol.23,No.3 , May 2008, pg. No. 1320-1331.
- Geoffrey R. Walker , and Paul C.Sernia, " Cascaded DC-DC converter connection of photovoltaic Modules,"IEEE Transaction on Power Electronics,Vol.19 ,July 2004 , pg. No. 1130-1139.
- Julio C. Rosas-Caro, Juan M. Ramirez, Pedro Martin Garcia-Vite , " Novel DC-DC Multilevel Boost Converter ." Proc. IEEE Power Electronics specialists Conference, 2008.
- AXELROD B., BERKOVICH Y., IOINOVICI A.: ' A cascaded boost- switched –capacitor-converter – two level inverter with an optimized multilevel output waveform," IEEE Transaction circuits sys. I, 2005 , 52 , (12), pg. No. 2763-2770.
- FAN Z.,PENG F.Z. , ZHAOMING Q: ' Study of the multilevel converters in DC-DC applications', IEEE 35th Annual Power Electronics Specialists Conf, PESC 04 , 2004 , Vol. 2, pg. No. 1702-1706.
- MIDDLEBROOK R.D:,'Transformerless DC-DC Converters with large conversion ratios,' IEEE Trans. Power electronics, 1988, 3 (4), pg. No. 484-488.