

Manager's Perception of the Importance of Environmental Accounting and its Effect on the Quality of Corporate Environmental Accounting Disclosures: Case from Indonesia

Lindrianasari
R. Weddie Adriyanto
Accounting Department Faculty of Economics
Lampung University - Indonesia

Abstract

The purpose of this study is to compare perceptions of managers in Indonesia concerning environmental accounting disclosure with actual environmental accounting disclosure. The value of this research is making an original contribution to develop instrument in exploring managerial perception of environmental accounting disclosure. Samples for this study are corporate managerial from listing companies in the Jakarta Stock Exchange and also annual report companies. This research has developed strategies to measure managerial perceptions of environmental accounting disclosure. Mail surveys design used on this study. Analysis used for testing relationship between managerial perception and environmental accounting disclosure is simple regression test. The dependent sample variable data is the latest data published in Jakarta Stock Exchange. This study finds a positive correlation between managerial perception of environmental accounting disclosure and actual environmental accounting disclosure. This result shows that disclosure quality and several legal sanctions in environmental aspects could be empowerment of regulator pasties to force managers to maintain their pollution and reported their activity also in their annual report. In hence, legitimacy theory is used as an explanation for corporate reactions to threats to its legitimacy vis-à-vis the social contract, while legitimacy theory infers motivation to incorporate environmental accounting disclosure

Keywords: *Managerial Perceptions, Environmental Accounting Disclosure, Legitimacy Theory*

Lindrianasari is currently a teaching staff at Accounting Program Faculty of Economics, University of Lampung, Indonesia, sari_170870@yahoo.com. R. Weddie Adriyanto is currently a teaching staff at the same institution, email: r_weddie@yahoo.com. This paper has been discussed in several seminars; National Seminar on Higher Education in February 2007, at the International Seminar on Writing the Ministry of National Education Republic of Indonesia, and at the International Industrial Relations Association (IIRA) at Sanur Beach, Bali – Indonesia 2010. Special thanks to A / Prof Greg Shailer from the Australian National University as a supervisor during the preparation of proposal of this study.

I. Introduction

Currently, almost countries are faced environmental problems. This condition requires the existence of a legitimacy that ensure the implementation of the arrangement a good social environment, especially with regard to the impact of corporate activity. In a previous study showed that most of the managers concerned and stated that the protection of environmental quality is important to be sufficient, but on the other hand, evaluating the quality of environmental disclosures in annual financial statements (annual report) show that the relationship was not significant. There are differences between the perceptions of managers with real environmental disclosures (Jaggi and Zhao, 1996). Increased demand for environmental information is not matched by the enthusiasm of the presenters report (in this case a company) to provide environmental information in their financial reports public. This asymmetry may be triggered by the fear of the managers of firms that environmental information will increase the company's obligation to control pollution as a consequence of company activity, and that this action eventually will trigger cost increasing (Jaggi and Zhao, 1996).

In a number of reasons, voluntary disclosure (voluntary disclosure) to the accounting environment is required as additional information (compulsory reporting) to provide accounting information to a wider audience and depth. This policy is expected to control the adverse effects on the environment arising from corporate activities. the issues raised in this study is whether there is a relationship between the perception of managers

in environmental accounting express accounting disclosure quality environment in which they express the company's financial statements. As well as this study will test the power of legitimacy theory in relation to perceptions of managers in addressing environmental problems. Sementar objectives of this study was to confirm whether the perception of managers on the importance of environmental accounting impact on the quality of the actual environmental accounting disclosures in the financial statements of companies in Indonesia. Another goal to find in this study was to obtain empirical evidence whether the conservation of living has become part of the company's management strategy. We assume that when managers perceive that environmental accounting is something that is important to be considered, then the company's regulation and also actions to be taken will lead to green action.

Compelling reason that can explain why this research must be done is because to note how far the perceptions and desires of managers, acting as the motor of the company, to control the environment. Furthermore, this research will also see, if the perception is reflected in the performance of environmental accounting disclosures in annual financial statements. The benefit to achieve from this study is to provide empirical evidence to the regulators in addressing the factors that encourage companies to make disclosures of environmental information. If it is necessary to form an environment in accounting regulation, the regulators in the fields of accounting can immediately prepare a new draft standard so that it can synergize with the law and the laws that already exist.

II. Theoretical Framework and Building Hypothesis

Legitimacy Theory is “A condition or a status which exists when an entity’s value system is congruent with the value system of the large social system of which the entity is a part. When a disparity, actual or potential, exists between the two value systems, there is a threat to the entity’s legitimacy (Lindblom, 1994, p.2)

“Legitimacy is a generalized perception or assumption that the actions of an entity are desirable, proper, or appropriate within some socially constructed system of norms, values, beliefs, and definitions”. (Suchman, 1995, p.574).

Several studies using legitimacy theory can explain the quality of corporate environmental accounting disclosures. Among of them are Hogner (1982), Guthrie and Parker (1989), Patten (1991, 1992, 1995), Gray, Kouhy and Lavers (1995), Deegan and Rankin (1996), Deegan and Gordon (1996), Walden and Schwartz (1997), Brown and Deegan (1998), Neu, Warsame and Pedwell (1998), Burn (1998), Cormier and Gordon (2001), Wilmshurst and Frost (2000), Deegan, Rankin and Tobin (2002), O'Donovan (1999, 2002), O'Dwyer (2002) and most recently the research by Mobus (2005). Most of these studies reported that the quality of environmental accounting disclosure and social disclosure have a strong correlation to legitimacy. These empirical studies shows that most environmental accounting disclosures and social disclosures are related to the attention of social accounting in the context of legitimacy.

2.1.1. Relation between Perception and Quality of Disclosure

The increasing needs and public awareness of environmental control, several studies analyzing the results using the theory of legitimacy (Mobus, 2005; Campbell, et al., 2003; Deegan, 2002; O'Donovan, 2002; Suchman, 1995; O'Dwyer, 2002; Jaggi and Zhao, 1996; Milne, 2002) generates results that through the legitimacy, compliance with accounting firms to provide environmental information in annual financial reports has increased. Mobus (2005) found that there is a negative correlation between legal sanctions concerning mandatory environmental disclosure rules with the deviations made by the company. That is, the stronger the applicable legal sanctions in a country, the less deviation with regulations stipulated by the regulators. This clearly shows that the actual legitimacy is needed to minimize damage in a general context. Studies conducted by O'Dwyer (2002) expand and clarify the use of legitimacy theory as motivation in the social accounting disclosures by presenting a narrative concept of legitimacy. Several studies have also shown that the real legitimacy comes from the pressure of societal (public), in this case is non-managerial stakeholders, and thus the company subsequently tried to convergence with public perception as a response to public pressure (O'Donovan, 1999; Bansal and Roth, 2000).

Furthermore, legitimacy theory is also used to describe the reaction of the pressure facing firms in dealing with the legitimacy of the social contract, while it also emerged the concept of legitimacy as a motivational theory of social disclosure (Deegan, 2002; O'Dwyer, 2003).

Thus be seen that social disclosures will be issued by the management company will actually highly colored by the social contract, which is none other than the basic foundation of legitimacy. As described by Gray et al. (1988), Patten, (1992, 1991), Woodward et al. (1996) and Deegan (2002), legitimacy theory is based on the concept of social contract between society and in society at large. How the company will continue to stand if the public believes that the company is consistent with the existing social contract.

Lindblom (1994) offers a theoretical structure in a theoretical view toward accounting studies that uses the framework to think of legitimacy theory, to explain voluntary social disclosures issued by the company manager. Lindblom explained that legitimacy theory can be thought appropriate framework in explaining why managers make voluntary disclosures. Although this disclosure rules should not be done, but to meet the legitimacy of the public, then the manager is doing a voluntary disclosure. To view the pattern of rule that forced (mandatory), Suchman (1995) strongly supports the explanation that the disclosure of environmental Lindblom mandatory environmental disclosure in corporate legitimacy, the legitimacy of an integrated and expanded itself. The explanation is more or less because of the legitimacy, of the needs arising in society, enabling the regulator to draw up a legal instrument that ultimately become something that should be done by the company. Conclusions can be drawn from the entire explanation above that the theory of legitimacy requires companies to show their responsibility not only to owners of capital, but also and more important is to fulfillment of the right of

the public. If the company does not show the pattern of cooperation and in public view it is contrary to the agreement, even detrimental to the public, then people can just pull the right company to continue its business. Although most studies show that strong environmental accounting disclosures relating to the theory of legitimacy, but there are also several studies that successfully rejected the results. The study states that the managers refuse to report their environmental accounting area because, despite the heightened environmental problems but they sure would gradually subside. Meanwhile, if in their annual financial statements disclose environmental problems so that stakeholders attach a negative perception of their company forever, and it will affect their positions as managers (O'Dwyer, 2002).

The result of study has suggestion that in fact what the manager is reported in the annual report will be strongly influenced by the perception managers. If managers have a perception that environmental factors are important information to be reported, then the quality of corporate environmental accounting disclosures would be good too. Conversely, if managers do not have the perception that environmental information is important information, the disclosure of corporate environmental accounting will also be a disclosure that is less quality. This statement was reinforced by the results of research Halkos et.al. (2002) who found, there are four of the most influential factor in the implementation of environmental management systems, namely firm size, legislations, environmental liabilities, and the perception. And legitimacy is a factor taken into account factors in influencing these perceptions. From these arguments we construct the

hypothesis that there is a positive and significant relationship between the perceptions of managers in Indonesia about the importance of environmental accounting disclosures by the quality of accounting disclosure of the actual environment in the financial statements of companies in Indonesia.

2.2. Relationship of Economic Performance with Quality of Disclosure

Previous researchs in the field of environmental accounting disclosures are trying to examine the relationship between environmental disclosures by economic performance. However, these findings still produce diverse conclusions in explaining the relationship between environmental disclosures by encouraging the economic performance of increasingly widespread research in this field. Testing the relationship between environmental disclosures by six accounting ratios to measure economic performance has been done Freedman and Jaggi (1982). They found statistical result is not strong enough to reject the null-hypothesis, which means they do not see any significant relationship between economic performances with environmental disclosure. Research conducted Lindrianasari (2008) also in line with research Freedman and Jaggi (1982) who failed to accept the alternative hypothesis on the relationship between the quality of disclosures with economic performances.

Richardson et al. (2001) observing corporate social disclosure and focus only on environmental disclosure. Richardson reported that there was a positive significant effect on the level of environmental disclosure in an overall cost of capital. Richardson further argues that the actual disclosures that the company will do

better at getting better profitability. This study fully supports Pava and Krausz (1996), who explained that the information disclosed by the company will not make the company lose the stakeholders. There should also be understood that the company that shows its social responsibility, proved to have better environmental performance than companies that do not show social responsibility. Al-Tuwaijri et al. (2003) claimed that good environmental performance must be supported by good economic performance. In other words, good economic performance would be associated with good environmental performance as well. The finding of Al-Tuwaijri *et al.* is in line with the findings of previous researchers (Porter and Linde's (1995), which supports the view that most investors are seeing that good environmental performance as an intangible asset related companies.

III. Research Method

3.1. Data and Collection Procedures

To obtain the primary data manager form of perception, we do spread the questionnaire by post and email. The questionnaire contains 17 items that consisted of 13 derived from previous research conducted by Jaggi and Zhao (1996) and added a fourth question about the legitimacy of the use Deegan (2002). Of the 17 items of questions indeed lead to the theory of legitimacy, especially items Deegan questions arising from the particular to the test of legitimacy theory. All the companies listed on the Jakarta Stock Exchange is our sample of this research. Secondary data, such as the quality of corporate environmental accounting disclosures, we get by doing literature study on the

company's annual report on the Capital Market Reference Center at the Indonesian Stock Exchange. Annual reports of companies used in this study is the year 2005 (because this study we did in 2006) and reporting to funders conducted in 2007.

3.2. Measurement Variables

3.2.1. Independent Variables

5 Likert scale attached to the whole question to test the perception of managers on the importance of environmental accounting information. Score one for the perception strongly disagree to the value of five (5) for the perception could not agree more. Answers to the questionnaire were obtained from the first level of validity and reliability. Reliability test results of the questionnaire obtained Cronbach's Alpha value of 83.8% which indicates that this questionnaire contains questions that can be believed clarity. 83.8% very good value which means that each respondent understood the question posed, therefore has a tendency not contradictory answers. While the value derived from product moment bivariate correlations to measure the validity questionnaires used an average of 0.05 at the level and some even reach the 0.01 level. This is evidence that there are questions of the questionnaire of this study have high value of validity.

Furthermore, for additional analysis as well as control variables, this research will also use the economic information relating to the quality of disclosure of environmental accounting. Control variables used in the study is the variable that has been used in previous studies. Kaiser and Schulze (2003) are using age, export, and legal ownership of their studies and found positive and signifi-

cant relationship between age and export of environmental performance. Richardson et al. (2001) reported that there was a positive significant effect on the level of environmental disclosure in an overall cost of capital. While Al-Tuwaijri et al. (2003) using the margin by doing approach, which compares with net income of net sales in research. Cormier et al. (2005) using five variables that represent the information used by investors as much respect for corporate environmental management, i.e. risk, capital markets, volumes, concentrate ownership and foreign ownership. This study will include four variables of economic performance control variables, namely age, export, margins, and the cost of the capital.

Age. Of a lawsuit against the social contract to the company at the time of standing in the middle of a community, in turn stimulate the legitimacy, making a strong reason to suspect that the old company, then the corresponding is the company's activities with their social environment. Because, if the company does not have a contribution to the environment (in the broad sense), then the company can't operate properly and lasting. Information age we get from the company prospectus and grouped into three.

- a) The value of one to represent companies that have listings \leq 10 years
- b) The value 2 to represent a company that has been listing 10 to 20 years
- c) The value of 3 to represent a company that has listings of more than 20 years

Export. The existence of the export ban for products from companies that do not perform the conservation of the environment, makes a compelling reason why

the export of variables included in the company's economic performance variables. The bigger the company expected to export an environment of accounting disclosure quality is also better because of environmental conservation activities are carried out is also good.

Margin. This research was conducted using margin approach al-Tuwaijri et al. (2003), which compares with net income of net sales, we assume that the greater the ratio the better the margin of corporate environmental accounting disclosures, or in other words there is a positive relationship between margin with environmental disclosure.

Company size. Several previous studies have consistently shown that there is a positive relationship between environmental disclosures by firm size (Scott, 1994; Neu et al., 1998; Cormier and Magnan, 1999). In this study, companies that used for the same size as that used Cormier (2005), ie ln-assets (natural logarithm). The objective of this study is to get the natural logarithm of the relative data to normal, because we know the asset value of each company is very large variance, so that surely will create abnormalities.

Risk. Cormier et al (2005) explains that volatility is measured by using the beta of the company. Attention to environmental accounting management which is currently increasingly becomes an important key to environmental information disclosure by companies to help investors and creditors understand the risks of their investments. High risk that the company will reduce information costs of investors if companies provide additional disclosure of the environment

(Lang and Lundholm 1993). Thus, there is allegedly a positive relationship between environmental risk disclosure.

3.2.2. Dependent variables .

Quality of disclosures were classified into five level (equivalent to 5 Likert' scale).

5th scale = good quality (to environmental disclosure + including value of money and/or to acquire ISO 14001 and its equivalent added by future planning

4th scale = good quality (to environmental disclosure + including value of money and/or to acquire ISO 14001 and its equivalent)

3rd scale = good enough quality (to sufficient environmental disclosure)

2nd scale = disclosure available is not very sufficient enough

1st scale = the environmental accounting disclosure do not have quality (in order to limited and even no environmental disclosure)

3.3. Analysis Tools

The analysis used to assess the relationship between manager perceptions of the importance of disclosure of environmental accounting with the accounting disclosure quality environment in Indonesia is a multiple regression.

$$Y_{(\text{QualDis})} = \alpha + \beta_1 X_{1(\text{Perceive})} + \beta_2 X_{2(\text{Age})} + \beta_3 X_{3(\text{Export})} + \beta_4 X_{4(\text{Margin})} + \beta_5 X_{5(\text{Assets})} + \beta_6 X_{6(\text{Risk})} + \varepsilon_i$$

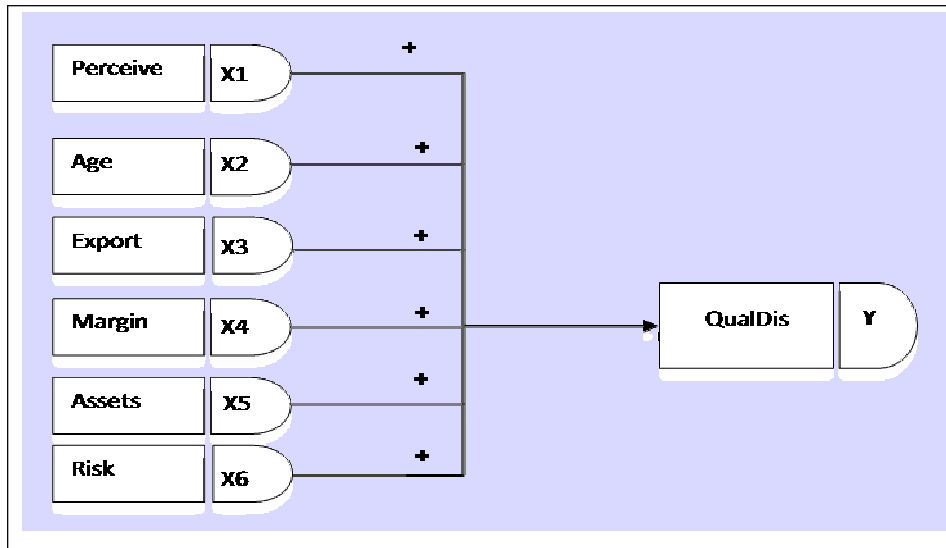

Figure 1. Research Model

IV. RESULTS AND DISCUSSION

From the total questionnaires sent, there were 283, a total of 52 questionnaires received back, or as much as 15%. After passing the assessment, only 39 questionnaires are eligible to as samples. This is because four of returned questionnaires did not answer the questionnaire thoroughly, six questionnaires came from similar companies and three questionnaires lateness (passed the period of analysis). This indeed is a common condition that occurs in research that uses mail surveys because of the weakness of researchers in the control of respondents. However, in using the mail survey, we have been attempting to interfere to make contact by telephone to several companies, to conduct a confirmation directly to the manager or director of finance of the questionnaires that we send. Randomly, 15 company finance directors successfully contacted by telephone, generally we do resend directly addressed to the name of the director who wanted to go. And this business is enough yield positive results,

which return the questionnaire to be more secure. Because we have to harmonize between the perception of corporate managers with the quality of disclosures made in corporate environments, the questionnaire which was sent we give the code a part that is not visible. This is just an attempt to become the basis of making conclusions that do not deviate from these research issues.

4.1. Assumptions of the Classical Test

Normality. Jarque Berra test results obtained probability value 0.89. This value is greater than the value of α (0.05), which means there is no problem of normality in the data used in this study. Residual data is normal, so that the data used in normal distribution.

- 1) Linearity. In the Ramsey RESET test tests obtained probability value 0.44. This value indicates that the linearity assumption is fulfilled, because the probability of linearity > 0.05 .
- 2) Auto-correlation. Autocorrelation test is used on Breusch-Godfrey

test the LM Serial Correlation Test, the result of probability of 0.91. This result is larger than α (0.05), and showed that there were no problems of autocorrelation in the model.

- 3) Homoscedasticity. On the test is a test used homoscedasticity White Heteroscedasticity, obtained probability value 0.01 which is smaller than the value of α (0.05), so that we can conclude that there are problems heteroscedasticity. Inconsistent data.
- 4) Multicollinearity. Multicollinearity test R2 value shows the value of -0.91 which is smaller than the model R2 value of 0.22. This value indicates that there is no problem in the data and also multicollinearity between variables.

From the whole classical assumption, we can conclude that our secondary data is a good and can do further testing, although there are problems homoscedasticity.

4.2. Hypothesis Testing.

The hypothesis of this study says there is a positive and significant relationship between the perception of managers in Indonesia about the importance of disclosure of environmental accounting with the quality of the actual environmental accounting disclosures in the financial statements of companies in Indonesia. From the statistical results obtained positive significant value to the relationship between the perceptions of managers of companies in Indonesia with the quality of their company's dissemination of environmental accounting items. With the level of 38% positive correlation shows that the quality of dis-

closure of environmental accounting in Indonesia affected by the perception of the manager of the company. Statistical significance value of 0.033 level (<0.5) can be concluded that there was indeed a significant relationship between the perception of managers in Indonesia about the importance of disclosure of environmental accounting on the quality of the actual environmental accounting disclosures in the financial statements of companies in Indonesia. With these results mean we can accept the hypothesis proposed in this study.

The results of this study do not support previous research conducted in China which found no positive relationship between perceptions of the actual report, manager of environmental accounting items in the annual report of company (Jaggi and Zhao, 1996). However, this research managed to support many of the previous studies which state that the theory of legitimacy is very dominant in explaining corporate environmental disclosures. These are studies performed by Hogner (1982), Guthrie and Parker (1989), Patten (1991, 1992, 1995), Gray, Kouhy and Lavers (1995), Deegan and Rankin (1996), Deegan and Gordon (1996), Walden and Schwartz (1997), Brown and Deegan (1998), Neu, Warsame and Pedwell (1998), Burn (1998), Cormier and Gordon (2001), Savage, Rowlands and Cataldo (1999), Wilmshurst and Frost (2000), Deegan, Rankin and Tobin (2002), O'Donovan (1999, 2002), O'Dwyer (2002) and Mobus (2005). This result is also support previous study conducted by Lindrianasari (2007) who found that companies with good environmental performance (showed by ISO 14001) will present good environmental information in corporate annual reports. It shows that

companies tend to give information which will have a positive impact on the company.

Tests for control variables (economic performances) of the company with

quality accounting disclosures showed that the overall economic performance variables do not have a significant relationship to the quality of environmental accounting disclosures.

Table 1 . Statistical Test Result of Control Variables

Variables	Age	Export	Margin	Assets	Risk
Sign.	0.387	0.784	0.665	0.801	0.545

Overall results of testing indicate that the perception variables proved to have a significant relationship to the quality of environmental accounting disclosures. And more interestingly, that the legitimacy appear to play an important role on the pattern of Indonesia's top managers view the importance of disclosure of environmental accounting. The results of this study both confirm the results of previous studies conducted Lindrianasari (2008) that shows the economic performance variables have no significance on the quality of disclosure of environmental accounting. This is also in line with previous research conducted Freedman and Jaggi (1982), but does not support research Richardson et al. (2001).

V. Conclusion and Recommendation

5.1. Conclusions

From the results and discussion in the previous chapter can be concluded that the study is successfully received the main of hypothesis proposed. The content of the annual report prepared by corporate managers is deeply influenced by perceptions of the manager. Positive and significant relationships are shown in the statistical tests in this study. Legitimacy theory which states that the activities of an entity corresponds to

building social systems, values and norms, and beliefs that exist in society, has encouraged the companies to disclose environmental information. This statement is strengthened by the results of testing the economic performance variables that do not have a significant relationship to the quality of environmental accounting disclosures.

5.2. Research Implications

1. If the facts prove the decreasing deviations with regulations stipulated by the regulators, this clearly shows that the actual legitimacy is needed to minimize damage in the overall context. Not be separated in the context of environmental accounting that ultimately affect the quality of the environment. If the rules had been imposed on all large companies in Indonesia to provide a reserve fund for environmental conservation, then at the end of the environment surrounding the company will be better. And it will be reflected in company disclosures.
2. It is time for regulators to consider the items that should be reported as related to environmental conservation. The consistence of monitoring and enforcement of the rules of the government, it will give full support to

achieve the environmental quality of life better. Furthermore, it is not only a slogan and opinions about "save environmental", but further more It can become a necessity that can be enjoyed by all in the society.

5.3. Research Limitations

There is no perfect study. Likewise with this study, there are some weaknesses and is expected to be corrected in future studies. In determining the quality of disclosure, we feel very thick and sometimes justification subjectivity factor is affected by corporate activity, which significantly has been done in the life of society. However, we have tried to keep promoting objectivity in assessing the quality of accounting disclosure in a relatively narrow time period, to be the consistency of assessment. Control variables used in this study is still very limited. There are still other variables that can be used as the control variable as it has been shown from the results of previous research. Subsequent research may consider the use of other economic performance variables such as cost of capital, leverage, and the legal ownership, are the results of some previous research showing a significant relationship on the disclosure of environmental accounting.

References

- Adams, C. A. (2002) "Internal Organizational factors Influencing Corporate Social and Ethical Reporting", *Accounting, Auditing & Accountability Journal*, Vol. 15, No. 2, pp. 223-250.
- _____, A., A Coutts, and Harte (1995a) "Corporate Equal Opportunities (non) Disclosure", *British Accounting Review*, Vol. 27, No. 2 pp. 87-108.
- _____, W.Y. Hill & C.B. Roberts (1995b) "Environmental, Employee and Ethical Reporting in Europe", *ACCA Research Report*, Vol. 41.
- Barthelot, S., Denis Cormier, Michel Magnan (2003) "Environmental Disclosure Research: Review and Synthesis", *Journal of Accounting Literature*, Vol. 22, pp. 1-44.
- Buhr, N. (1998) "Environmental performance. Legislation and annual report disclosure: the case of acid rain and Falcolnbridge", *Accounting, Auditing & Accountability Journal*, Vol. 11, No. 2, pp. 163-190.
- Campbell, D., Barrie Craven and Philip Shrives (2003) "Voluntary Social Reporting in Three FTSE Sectors: A Comment on Perception and Legitimacy", *Accounting, Auditing & Accountability Journal*, Vol. 16, No. 4, pp. 558-581.
- Cormier, D. & Gordon, I. (2001) "An examination of social and environmental reporting strategies." *Accounting, Auditing & Accountability Journal*, Vol. 14, No. 5, pp. 587-616.
- _____, Michel Magnan, Barbara Van Velthoven (2005) "Environmental Disclosure Quality in Large German Companies: Economic Incentives, Public Pressure or Institutional Conditions?" *European Accounting Review*, Vol. 14, No. 1, pp. 3.
- Deegan, C. (2002) "The Legitimising Effect of Social and Environmental Disclosure - A Theoretical Foundation" *Accounting, Auditing & Accountability Journal*, Vol. 15, No. 3, pp. 282-311.

- Deegan, C. A., M. Rankin (1996) "Do Australian Companies Report Environmental News Objectively? An Analysis of Environmental Disclosure by Firms Prosecuted Successfully the Environmental Protection Authority", *Accounting, Auditing & Accountability Journal*, Vol. 9, No. 2, pp. 50-67.
- _____, _____ (1997) "The Materiality of Environmental Information to Users of Annual Reports", *Accounting, Auditing & Accountability Journal*, Vol. 10, No. 4, pp. 562-583.
- Deegan, C. & B. Gordon. (1996) "A Study of Environmental Disclosure Practices of Australian Corporations" *Accounting and Business Research*, Vol. 26, No. 3, pp. 187-199.
- _____, Rankin, M., & Tobin, J. (2003) "An examination of the corporate social and environmental disclosure of BHP from 1983-1997: a test of legitimacy theory", *Accounting, Auditing & Accountability Journal*, Vol. 15, No. 3, pp. 312-343.
- Guthrie, J.E. & Parker, L.D. (1989). "Corporate social reporting: a rebuttal of legitimacy theory", *Accounting and Business Research*, Vol. 9, No. 76, pp. 343-352.
- Hogner, R.H. (1982) "Corporate social reporting; eight decades of development at US Steel." *Research In Corporate Performance and Policy*, Vol. 4, pp. 243-250.
- Jaggi R & Zhao, B. (1996) "Environmental Performance and Reporting: Perceptions of Managers and Accounting Professionals in Hong Kong", *The International Journal of Accounting*, Vol. 31, No. 3, pp. 333-346.
- Lindblom, C. K. (1994). *The Implications of Organizational Legitimacy for Corporate Social Performance and Disclosure*. Critical Perspectives on Accounting Conference, New York.
- Lindrianasari, 2007. Hubungan antara Kinerja Lingkungan dan Kualitas Pengungkapan Lingkungan dengan Kinerja Ekonomi Perusahaan di Indonesia, *Jurnal Akuntansi & Auditing Indonesia* Vol. 11, No. 2, pp. 159-172.
- _____, 2008. Hubungan Hubungan antara Kinerja Lingkungan, Pengungkapan Lingkungan dan Kinerja Ekonomi Perusahaan di Indonesia, *Jurnal Akuntansi dan Bisnis*, Vol. 8, No. 1, pp. 25-32.
- Milne, M. J. (2002) "Securing Organizational Legitimacy: An Experimental Decision Case Examining The Impact of Environmental Disclosure", *Accounting, Auditing & Accountability Journal*, Vol. 15, No. 3, pp. 372-405.
- Mobus, J. L. (2005) "Mandatory Environmental Disclosure in Legitimacy Theory Context." *Accounting, Auditing & Accountability Journal*, Vol. 18, No. 1, pp. 492-517.
- New, D., Warsame, H. & Pedwell, K. (1998) "Managing public impressions: environmental disclosures in annual reports", *Accounting, Organizations and Society*, Vol. 23, No. 3, pp. 265-288.
- O'Donovan, G. (1999) "Managing Legitimacy Though Increased Corporate Environmental Reporting: An Exploratory Study", *Interdisciplinary Environmental Review*, Vol. 1, No. 1, pp. 63-99.
- _____, _____ (2002) "Environmental

- "Disclosure in the Annual Report: Extending the Capability and Predictive Power on Legitimacy Theory", *Accounting, Auditing & Accountability Journal*, Vol. 15, No. 3, pp. 344-371.
- O'Dwyer, B. (2003) "Managerial Perception of Corporate Social Disclosure: An Irish Story", *Accounting, Auditing & Accountability Journal*, Vol. 15, No. 3, pp. 406-436.
- _____, Jeffrey Unerman, John Bradley (2005) "Perceptions on the Emergence and Future Development of Corporate Social Disclosure in Ireland." *Accounting, Auditing & Accountability Journal*, Vol. 18, No. 1, pp. 14-43.
- Patten, D. (1995) "Variability in Social Disclosure: A Legitimacy-Based Analysis." *Advances in Public Interest Accounting*, Vol. 6, pp. 273-285.
- Patten, D.M. (1991) "Exposure, Legitimacy and Social Disclosure." *Journal of Accounting and Public Policy*, Vol. 10, pp. 297-308.
- _____. (1992) "Intra-Industry Environmental Disclosure in Response to the Alaskan Oil Spill: A Note on Legitimacy Theory." *Accounting, Organizations and Society*, Vol. 17, No. 5, pp. 471-475.
- R.H. Gray, R. K., & S. Lavers (1995a). "Constructing a Research Database of Social and Environmental Reporting by UK Companies: A Methodological Note", *Accounting, Auditing & Accountability Journal*, Vol. 8, No. 2, pp. 78-101.
- Schwartz, W. D. W. a. B. N. (1997). "Environmental Disclosure and Public policy Pressure." *Journal of Accounting and Public Policy*, Vol. 16, pp. 125-154.
- Suchman, M. C. (1995) "Managing Legitimacy: Strategic and Institutional Approaches" *Academy of Management Review*, Vol. 20, No. 3, pp. 571-610.
- Walden, W.D. & Schwartz, B.N. (1997) "Environmental disclosure and public policy pressure", *Journal of Accounting and Public Policy*, Vol. 16, pp. 125-154.
- Wilmshurst, T. D., Geoffrey R. Frost (2000) "Corporate Environmental Reporting A Test of Legitimacy Theory", *Accounting, Auditing & Accountability Journal*, Vol. 13, No. 1, pp. 10.
- Woodward, D., Pam Edwards & Frank Birkin (2001) "Some Evidence on Executives' Views of Corporate Social Responsibility", *British Accounting Review*, Vol. 33, pp. 357-397.

Issues In Social and Environmental Accounting (Issues in SEA)

ISSN : 1978-0591

Hasan Fauzi, Sebelas Maret University, Indonesia

CALL FOR PAPERS (8th ISSUE)

Issues in SEA is an international journal as networking and dissemination means of practices and theory of social and environmental accounting. Since Problems of social and environmental in general and in accounting context in specific have been global issue, it is necessary for us to share and cooperate to make better the corporate financial, social and environmental performance. *Issues in SEA* publishes rigorous, original and innovative scholarly papers dealing with theoretical, empirical, applied, surveys, and case studies providing meaningful insights into the subject areas.

Subject Coverage

Topics include but are not limited to:

- Environmental accounting
- Social accounting
- Ethical issues in accounting and financial reporting
- Corporate governance and accountability
- Accounting for the Costs and Benefits of CSR-related Activities
- Accounting and Disclosure of Environmental Liabilities
- Corporate Environmental Strategy
- Corporate Social Performance
- Corporate social responsibility and management control
- Corporate social responsiveness
- Triple bottom line performance

Specific Notes for Authors

Submitted papers must not have been previously published nor be currently under consideration for publication elsewhere. All papers are refereed through a double blind process. *Issues in SEA* is published biannually in June and December, so each contributor is encouraged to submit the papers before 30 May and 30 November. See information for contributors and submission guidelines to submit your paper. The contributors are required to submit their paper electronically, using Microsoft word, to this address: hfauzi@icseard.uns.ac.id or hfauzi2003@gmail.com

Contact: +62271827003 fax +62271827003

Web Address: <http://isea.icseard.uns.ac.id> and <http://web.ebscohost.com>

Publication of Indonesian Centre for Social and Environmental Accounting Research and Development (ICSEARD) and EBSO Publishing

Faculty of Economics
Sebelas Maret University,
Jl. Ir Sutami 36 A
Solo 57126
Indonesia

Associate Editors:

Hussain, Mostaq M., University of New Brunswick, Canada
Komtyah, University of Trisakti, Indonesia

Editors Advisors:

Fuglister, Jayne, Cleveland State University, USA
Gray, Rob, St. Andrews University, Scotland UK
Na'im Alinun, Gadjah Mada University, Indonesia
Syakhroza, Akhmad, University of Indonesia, Indonesia

Members of Boards:

1. **Adams, Carol**, La Trobe University, Australia
2. **Al-Khadash, Husam Aldeen**, Hashemite University, Jordan
3. **Aras, Gulser**, Yildiz Technical University, Turkey
4. **Ball, Amanda**, University of Canterbury, New Zealand
5. **Berman, Shawn**, University of New Mexico, USA
6. **Brown, Judy**, Victoria University of Wellington, New Zealand
7. **Brown, Alistair**, Curtin University of Technology, Australia
8. **Campbell, David**, New Castle University, UK
9. **Choi, Jong-Seo**, Pusan National University, Korea
10. **Crowther, David**, De Montfort University, United Kingdom
11. **Donleavy, Gabriel D.**, University of Macau, China
12. **Freeman, Edward**, University of Virginia, USA
13. **Georgakopoulos, Georgios**, University of Amsterdam, The Netherlands
14. **Ghazali, Imam**, University of Diponegoro, Indonesia
15. **Guthrie, James**, The University of Sydney, Australia
16. **Husted, Bryan**, ITESM/Instituto de Empresa, Mexico
17. **Ibrahim, Daing N.**, University of Sains Malaysia, Malaysia
18. **Idris, Kamis**, Universiti Utara Malaysia
19. **Jasch, Christine Maria**, The Institute for Environmental Management and Economics, Austria
20. **Kent, Pamela**, Bond University, Australia
21. **Kokubu, Katsuhiko**, Kobe University, Japan
22. **Lawrence, Stewart**, University of Waikato, New Zealand
23. **Mahoney, Lois**, Eastern Michigan University, USA
24. **Murray, Alan**, Sheffield University, UK
25. **Maunders, Keith**, University of the South Pacific, Fiji
26. **Magness, Vanessa**, Ryerson University, Toronto Canada
27. **Nik Ahmad, Nik Nazli**, International Islamic University Malaysia, Malaysia
28. **O'Donovan, Garry**, University of Tasmania, Australia
29. **Orlitzky, Marc**, University of Redlands, USA
30. **Palliam, Ralph**, American University of Kuwait
31. **Parker, Lee**, University of South Australia
32. **Pondeville, Sophie Marquet**, Université University of Namur, Belgium
33. **Rahman, Azhar A.**, Universiti Utara Malaysia, Malaysia
34. **Roberts, Robin**, University of Central Florida, USA
35. **Rasheed, Abdul A.**, University of Texas at Arlington
36. **Schaltegger, Stefan**, University of Luebneg Germany
37. **Sen, Swagata**, University of Calcutta, India
38. **Savage, Deborah**, EMA Research & Information Center (EMARIC), USA
39. **Suharjanto, Djoko**, Sebelas Maret University, Indonesia
40. **Stapleton, Pamela**, University of Manchester UK
41. **Svensson, Goran**, Oslo School of Management, Norway
42. **Elijido-Ten, Evangeline**, Swinburne University of Technology, Australia
43. **Belal, Ataur**, Ashton University, UK
44. **Freedman, Martin**, Towson University, USA
45. **Chen, Jennifer C.**, Brigham Young University, Hawaii, USA
46. **Cho, Charles H.**, Concordia University, Canada
47. **Patten, Den**, Illinois State University, USA
48. **Larrinaga-González, Carlos**, Burgos University, Spain
49. **Laine, Matias**, University of Tampere, Finland
50. **Tarta, Monica**, The Academy of Economic Studies, Bucharest, Romania
51. **Tilt, Carol A.**, Flinders University, South Australia
52. **Koleva, Petia**, University of Nantes, France
53. **Yusoff, Haslinda**, UiTM, Malaysia
54. **Zein, Mustafa M.**, UiTM, Malaysia
55. **Selvam, V.**, VIT University, India
56. **Jardat, Rémi**, ISTECC, Paris, France
57. **Calyiurt, Kymet Tunca**, Trakya University, Turkey
58. **Momin, Mahmood Ahmed**, Auckland University of Technology, NZ

This academic article was published by The International Institute for Science, Technology and Education (IISTE). The IISTE is a pioneer in the Open Access Publishing service based in the U.S. and Europe. The aim of the institute is Accelerating Global Knowledge Sharing.

More information about the publisher can be found in the IISTE's homepage:

<http://www.iiste.org>

The IISTE is currently hosting more than 30 peer-reviewed academic journals and collaborating with academic institutions around the world. **Prospective authors of IISTE journals can find the submission instruction on the following page:**

<http://www.iiste.org/Journals/>

The IISTE editorial team promises to review and publish all the qualified submissions in a fast manner. All the journals articles are available online to the readers all over the world without financial, legal, or technical barriers other than those inseparable from gaining access to the internet itself. Printed version of the journals is also available upon request of readers and authors.

IISTE Knowledge Sharing Partners

EBSCO, Index Copernicus, Ulrich's Periodicals Directory, JournalTOCS, PKP Open Archives Harvester, Bielefeld Academic Search Engine, Elektronische Zeitschriftenbibliothek EZB, Open J-Gate, OCLC WorldCat, Universe Digital Library, NewJour, Google Scholar

