

# Design, Fabrication and Performance Evaluation of a Motorized Maize Shelling Machine

D.O Aremu<sup>1</sup> I.O. Adewumi<sup>2</sup> J.A. Ijadunola<sup>1</sup>

1.Department of Agricultural Engineering, Federal College of Agriculture, Ibadan, Nigeria

2.Department of Industrial and Production Engineering, Faculty of Technology, University of Ibadan, Nigeria

## Abstract

The design and fabrication of a power operated maize shelling machine was carried out in the engineering workshop of both Allamit Nigeria Limited, Ibadan and Federal College of Agriculture Moor Plantation, Ibadan, Oyo – State, Nigeria. The length, width and height of the machine are respectively 830mm, 605mm and 950mm. The machine can easily be carried with vehicle to a farm for operation. The performance evaluation was carried out using the NIS standard. This involved using three pulleys to vary the shaft shelling speed from 623rpm to 823rpm to 886rpm at moisture content of a maize cob viz: 13%, 15% and 17% respectively. Result showed that shelling efficiency, cleaning efficiency, grain recovery efficiency and output capacity were 87.08%, 95.89% and 623.99kg/hr respectively which were at highest values at 13% moisture contents of maize and at 886rpm shelling speed. Thus, shelling of maize at 13% moisture content dry basis using 886rpm shelling speed resulted into the highest efficiencies and capacity of the machine when compared with other moisture contents and shelling speeds. Result showed that shelling efficiency, cleaning efficiency grain recovery efficiency and output capacity were 87.08%, 95.89%, 95.48% and 623.99kg/hr respectively which were the highest values at 13% moisture contents of maize and at 886rpm shelling speed.

**Keywords:** Performance evaluation, maize Sheller, fabrication

## 1.0 Introduction

Maize (*Zea mays*) is an important cereals crop which belongs to a grass family (Gramineae) producing small edible seeds which was said to have originated from Mexico over years (Iwena, 2002). It is the world's best adapted crop, growing between latitudes 58°N and 40°S of the equator. It is a versatile grain crop and commonly known as corn in America. The natural endowment of high rainfall, high light intensities, and favourable temperature in the cultivation of maize make it to be one of the world's most versatile seed crops (Kay, 1987).

Maize production in Nigeria is of great importance with the increase in population and use of maize grain, the market demand for maize grain also increased. However, maize shelling in developing and under-developed nations has been and remains a serious problem to its processing as it is tedious and often require considerable labour hours (Abdullahi *et al.*, 1979).

In industrialized countries, maize is largely used as livestock feeds and as raw material for industrial products, while in low income countries; it is mainly used for human consumption (Ndirika, 1995). In Sub-Saharan Africa, maize is a staple food for an estimated 50% of the population (IITA, 1996). Maize is an important source of carbohydrate, protein, iron, vitamin B and minerals. In Africa, maize is consumed as a starchy base in wide variety of porridges and pastes. Green maize (fresh on the cob) is eaten parched, baked, roasted or boiled which play an important role in filling the huge gap after dry season (IITA, 1996). In rural communities, the dwellers use maize in production of porridge (fura) and "Tuwo". Owing to demand for maize to human diet, its shelling and cleaning has been and remains a serious problem to local dwellers in their communities (Wenham, 1995).

Maize is a vital raw material in industry. Corn starch, corn oil, corn syrup and sugar are the chief industrial products obtained from maize. Corn starch is used for starching clothes. The starch is also employed in the manufacture of asbestos, ceramics, dykes, plastics, oil cloth and linoleum. Corn syrup is used in shoe polish, glassine paper and rayon in tobacco industries. Corn sugar finds their use in the manufacture of chemicals, leather preparation, dykes and explosives. The maize when cooked under acids produces furfural, a compound used in the production of adipontrile (nylon) in the restinging of diesel and lubricating oils. The stalks and leaves are sometimes used for making paper, paper board and wall board. Pulverised maize cobs are used extensively for removing carbon from airplane motors (Kochar and Kenneth, 1988).

## Shelling of Maize

Shelling is the process of removing seed or grain from their respective cobs for both human and industrial use. Shelling is best attained when the moisture content is as low as 13% (ASHRAE, 1998). In the olden days and in rural communities, primitive method of shelling includes, beating with stick, crushing with mortar and pestle, hand shelling and therefore consume much human energy and time (Sunghal and Thierstein, 1987).

Shelling is an indispensable process which is undertaken to maximize space and promote the easy handling of grains. Maize shelling, if done manually is one of the most labour consuming processes in corn post harvest

handling. The existing maize shellers are normally large and heavy, require high power input to operate and produces low product quality in terms of percentage seed breakage and purity (Wagami, 1997). Damaged kernels are susceptible to insect and moulds thereby increasing the incidence of aflatoxin contamination. Thus, there is a need to develop a maize sheller with higher efficiency, better product quality and powered with small engine.

## 2. METHODOLOGY

### MATERIALS AND METHODS

#### 2.1 Design Considerations

Different design factors were taken into consideration. These are as follows.

##### 2.1.1 Durability

The parts of machine are chosen that they may last for longer period before any sign of damage may be noticed.

##### 2.1.2 Strength

Before any construction work could be done, the behaviour of stress action on the machine parts should depend on the load that machine is to carry and this is very essential.

##### 2.1.3 Corrosiveness

Machine parts must be prevented from moisture as to prevent corrosion of the machine. This is achieved by painting the machine parts.

##### 2.1.4 Availability

This is one of the most important factors to be considered when selecting materials. The materials must be readily available at low cost to ease the construction work and maintenance. In respect of the above fact, the materials used in the production of this machine were sourced for locally in a nearby market area in Ibadan, Oyo State.

#### 2.2 Design Analysis and Fabrication

##### 2.2.1 Design of Hopper

###### A. Angle of Inclination

Hopper design is based on a common criterion for it to function. The criterion is called the “Angle of repose”. Angle of repose is the maximum slope at which a heap of any loose or fragmented bulk material will stand without sliding. It can also be called the angle of friction of rest (Eugene and Theodore, 1986).

This type of hopper is a gravity discharge one and the recommended angle of inclination of hopper for agricultural materials is  $8^\circ$  or more, higher than the angle of repose (Micheal and Ojha, 1987). The angle of repose of maize is  $27^\circ$  (Richey, 1982). This hopper has a shape of a truncated prism.

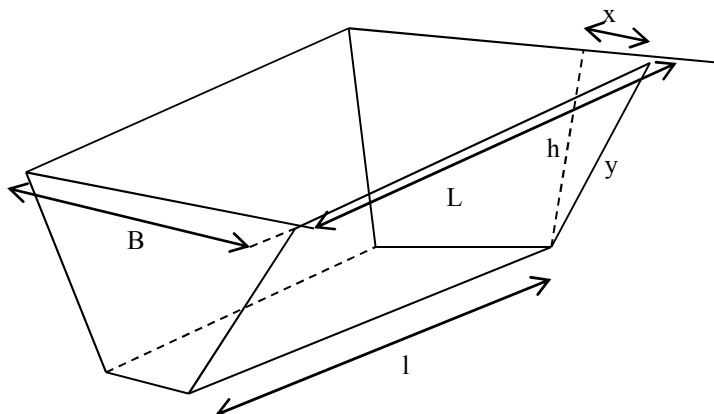

Fig 1: The Hopper (Scale 1:9)

#### Cost Analysis

The materials and specifications used for the construction work are illustrated in the table below.

**Table 1: Cost Analysis of Maize Shelling Machine**

S/N	Materials	Specifications	Quantity	Unit Cost (N)	Total Cost (N)
1	Angle Iron	45mm x 45mm x 6.25mm	3	1,000	3,000
2	Metal Sheet	Guage 16	1	5,500	5,500
3	Iron rod	14mm	2	750	1500
4	Hacksaw blade	Eclipse	2	150	300
5	Grinding disc	Druco	1	300	300
6	Cutting disc	Druco	1	300	300
7	Electrode	Guage 12	1 Packet	750	750
8	Electrode	Guage 10	1 packet	650	650
9	A- Belt	A- 56	1	300	300
10	Bolt and Nut	M – 13	12	20	240
11	Shaft	22mm	1	1,200	1,200
12	Flat bar	60mm	1	1,200	1,200
13	Bearing	P 206	4	850	3,400
14	Galvanised pipe	Q 6mm	4 feet	250	1,000
15	Lubricant		¼ litres	200	200
16	Blue paint	Dulux	½ litres	600	600
17	Maize Cobs		1 bag	3,000	3,000
18	Labour			6,000	6,000
19	Transportation			4,000	4,000
20	Miscellaneous			3,000	3,000
21	Diesel		20 litres	100	2,000
22	Bolt and Nut	M – 17	12	30	300
23	Metal Sheet	Guage 18	1	4,500	4,500
24	Pulley (Shaft)	130mm	1	1,500	1,500
25	Pulley(Blower)	79mm	1	1,500	1,500
	<b>Total Cost</b>				<b>46,750</b>

From the fig. 1

B= Width of hopper top= 280 mm (chosen)

L = Length of hopper top = 285 mm (chosen)

b = Width of hopper bottom = 130 mm (chosen)

l= Length of hopper bottom = 160 mm (chosen)

h= Vertical height of hopper = 220 mm (chosen)

y = Slant height of hopper

Ø = Angle of inclination of hopper

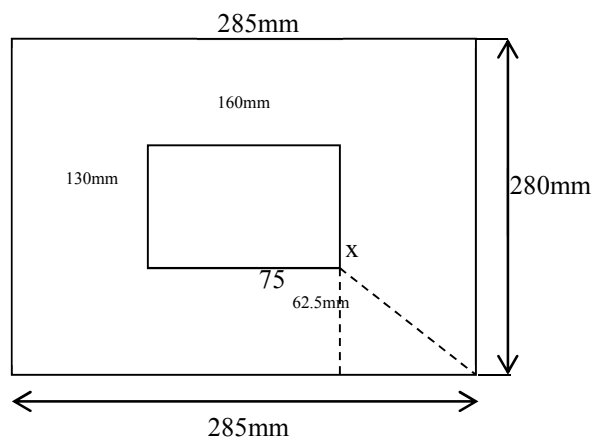

**Fig. 2: Plan View (Hopper) (Scale 1:9)**

$$x = \sqrt{75^2 - 62.5^2}$$

$$x = \underline{41.46\text{mm}}$$

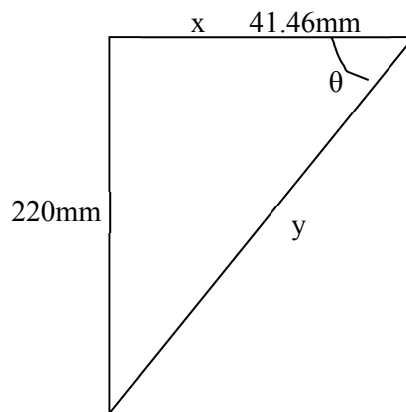

**Fig 3: Right Angle` Triangle (Hopper) (Scale 1:9)**

Therefore, from the right angled triangle (Fig. 3)

$$\text{Tan } \theta = \frac{220}{41.46}$$

$$\text{Tan } \theta = 5.306$$

$$\theta = 79.3^\circ$$

Hence, since the angle of inclination of hopper,  $\theta$  is greater than the angle of repose of maize plus  $8^\circ$ , the hopper will do the required job.

**B. The Volume of Hopper**

The volume of hopper can be calculated using equation below:

$$V_n = \frac{(V_{ct} - V_{cb})}{2} \dots\dots\dots(1)$$

Where  $V_{ct}$  = Volume of cuboid having the hopper top, has its length and breadth

$V_{cb}$  = Volume of cuboid having the hopper, bottom has its length and breadth

Note: The height of cuboid for calculating  $V_{ct}$  and  $V_{cb}$  is the vertical height of the hopper (220 mm).

$$\begin{aligned} \text{Therefore, } V_{ct} &= 285 \times 280 \times 220 \\ &= 17556000 \text{ mm}^3 \\ V_{ct} &= 0.017556 \text{ m}^3 \\ V_{cb} &= 160 \times 130 \times 220 \\ &= 4576000 \text{ mm}^3 \\ V_{cb} &= 0.004576 \text{ m}^3 \end{aligned}$$

Therefore,

Volume of hopper =

$$V_h = \frac{(0.017556 - 0.004576)}{2} - 0.004576$$

$$= \frac{0.01298 - 0.004576}{2}$$

$$= 0.004202 \text{ m}^3$$

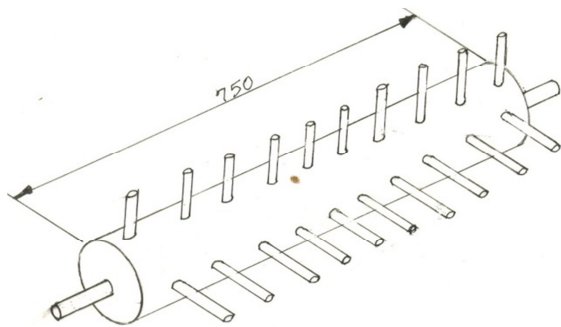

Fig. 4: The Shelling Drum with Spikes (Scale 1:9)

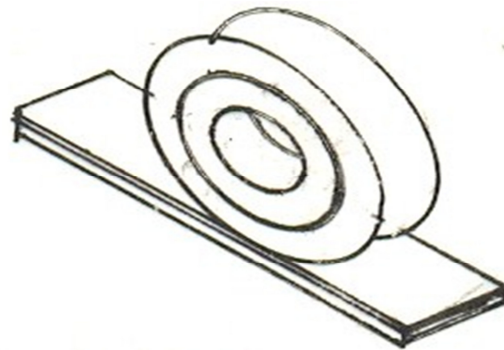

Fig 5: The Bearing Housing (Scale 1:9)

**2.2.2 Determination of number of spikes on the shelling cylinder,  $N_p$**

The number of spikes on the shelling cylinder is given by

$$N_p = \frac{L_c}{S_{sr}} \times \frac{\pi d}{S_{sc}} \dots \dots \dots (2)$$

Where,  $N_p$  = Number of spikes on shelling cylinder  
 $L_c$  = Length of shelling cylinder = 645 mm  
 $S_{sr}$  = Spike spacing on row = 50 mm  
 $S_{sc}$  = Spike spacing on circle = 80 mm  
 $d$  = Diameter of shelling cylinder = 92 mm

$$\begin{aligned} \text{Therefore } N_p &= \frac{645}{50} \times \frac{\pi \times 92}{80} \text{ mm} \\ &= (12.90) \times (3.6128) \\ &= 46.6 \\ &= 47 \end{aligned}$$

The total number of spikes on the shelling cylinder,  $N_p = 47$  (Fig. 4)



Plate 1: Constructed Maize Shelling Machine

**2.2.3 Determination of pulley diameter of cylinder shaft**

(a) The diameter,  $D_2$  is given by the formular

$$D_2 = \frac{(n_1 D_1)}{n_2} \dots \dots \dots (3)$$

Where  $n_1$  = electric motor speed = 1440 rpm  
 $D_1$  = diameter of electric pulley = 80 mm  
 $D_2$  = diameter of driven pulley = 130 mm  
 $n_2$  = shelling speed

$$n_2 = \frac{n_1 D_1}{D_2} = \frac{1440 \times 80}{130}$$

$$n_2 = 886 \text{ rpm}$$

- (b) Pulley diameter of shelling cylinder shaft for the speed of 823 rpm

$$D_2 = \frac{n_1 D_1}{n_2}$$

$$= \frac{1440 \times 80}{823}$$

Therefore  $D_2 = 140 \text{ mm}$  (Fig. 7)

- (c) Pulley diameter of shelling cylinder shaft for the speed of 623 rpm

$$D_2 = \frac{n_1 D_1}{n_2}$$

$$D_2 = \frac{1440 \times 80}{623}$$

$$D_2 = 185 \text{ mm}$$

- (d) Pulley diameter of blower shaft is kept constant to get the constant blowing speed as calculated below

$$n_2 = \frac{n_1 D_1}{D_2}$$

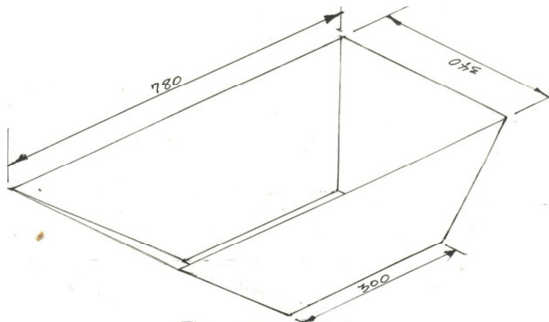

Fig. 6: Grain Collector (Scale 1:9)

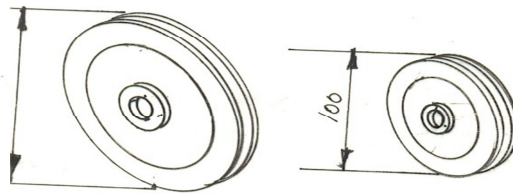

Fig 7: The Pulleys (Scale 1:9)

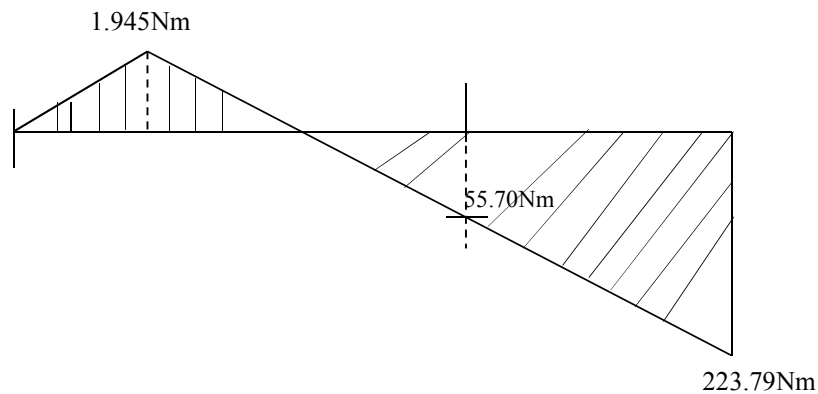
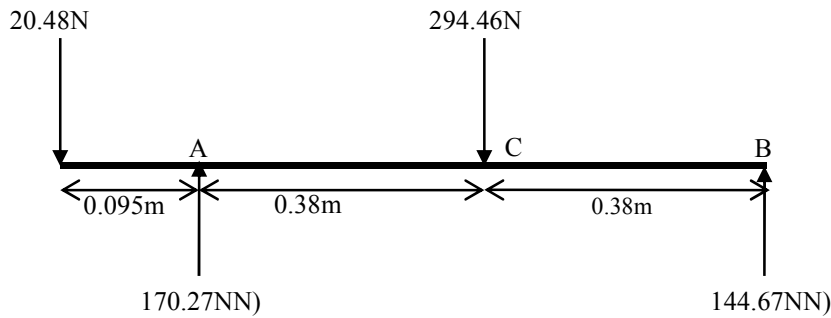
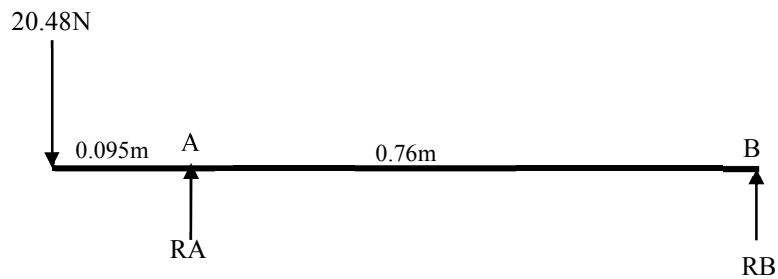

Fig 9: Vertical Bending Moment Diagram

C. Calculation of Horizontal Loading



**Fig 10: Horizontal Loading**

Taking moment about A (From Fig. 10 above)

$$0 = (20.48 \times 0.095) + R_B \times 0.76$$

$$0 = 1.9456 + 0.76 R_B$$

$$R_B = \frac{-1.9456}{0.76} = -2.56\text{N}$$

$$R_A + R_B = 20.48\text{N}$$

$$\text{Therefore } R_A = 20.48 - 2.56 = 17.92\text{N}$$

At o,  $M_{BH} = 0$

At A, when  $x = 0.095\text{m}$

$$M_{BH} = 20.48 \times 0.095 = 1.9456 = 2.0\text{Nm (Fig. 11)}$$

At B, when  $x = 0.855\text{m}$

$$M_{BH} = (20.48 \times 0.855) - (17.92 \times 0.76)$$

$$= 17.5104 - 13.6192$$

$$M_{BH} = 3.8912\text{Nm (Fig. 11)}$$

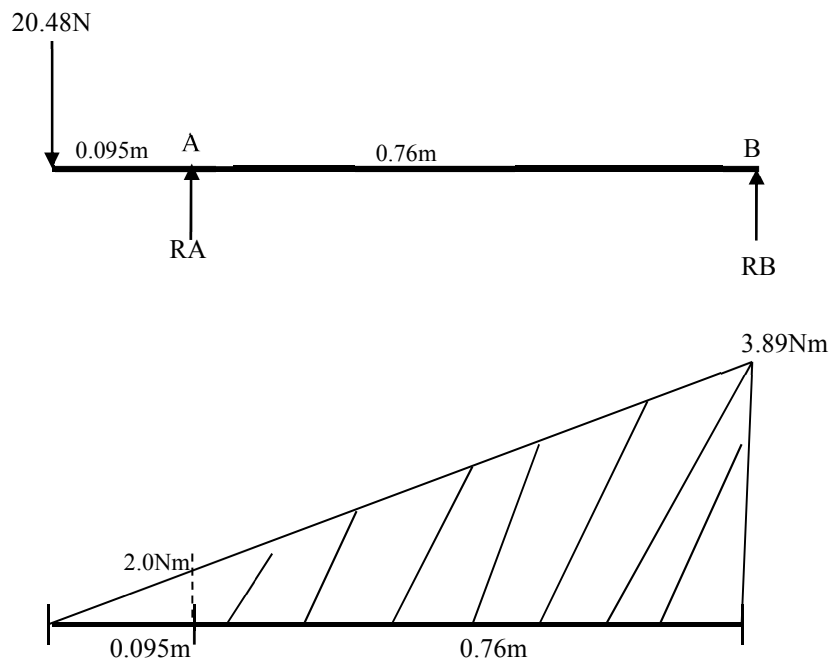

**Fig 11: Horizontal Bending Moment Diagram**

D. Calculation of Torsional Moment of Shaft

$$M_t = \frac{P}{2\pi N} \dots \dots \dots (13)$$

Where  $M_t$  = torsional moment (Nm)

Power (watts)

$N$  = Speed (rev/min)

$$M_t = \frac{4532.85}{2 \times \pi \frac{886}{60}} = \frac{4532.85}{92.7818} = 48 \text{Nm}$$

**E. Calculation of Maximum Bending Moment**

$$M_b = \sqrt{M_{BV}^2 + M_{BH}^2} \dots\dots\dots (14)$$

Where  $M_b$  = maximum bending moment (Nm)

$M_{BV}$  = Maximum vertical bending moment (Nm)

$M_{BH}$  = Maximum horizontal bending moments (Nm)

Therefore  $M_b = \sqrt{223.79^2 + 3.89^2} = 223.82 \text{Nm}$

**2.2.8 Determination of Shaft Diameter**

The required diameter for a solid shaft having combined bending and torsional loads is obtained from ASME code equation (Hall et al; 1983).

$$d^3 = \frac{16}{\pi S_s} \sqrt{(k_b M_b)^2 + (k_t M_t)^2} \dots\dots\dots (15)$$

Where  $d$  = diameter of shaft

$k_b$  = combined shock and fatigue factor applied to bending moment

$k_t$  = combined shock and fatigue factor applied on torsional moment

$S_s$  = allowable stress for shaft without key way

**Assumption**

$S_s = 47 \text{MN/m}^3$

$k_t = k_b = 1.5$

$$d^3 = \frac{16}{\pi S_s} \sqrt{(k_b M_b)^2 + (k_t M_t)^2}$$

$$d^3 = \frac{16}{\pi \times 47 \times 10^6} \sqrt{(1.5 \times 223.82)^2 + (1.5 \times 48)^2}$$

$$d^3 = \frac{16 \cdot 343.363}{\pi \times 47 \times 10^6}$$

$$d^3 = \frac{5493.80}{\pi \times 47 \times 10^6}$$

$$d^3 = 3.72 \times 10^{-5}$$

$$d = 0.0289 \text{m}$$



### 3.0 RESULTS AND DISCUSSION

**Table of mean for Interaction Effect between Moisture contents and shaft shelling speeds**

Shelling speed/ Efficiencies		623rpm	823rpm	886rpm
<b>Moisture content</b>				
13%	Shelling efficiency (%)	62.85	71.45	87.07
	Cleaning efficiency	94.56	93.38	95.48
	Grain Recovery efficiency	96.32	97.19	95.48
	Sheller Performance Index	91.08	90.76	91.55
	Total Grain Losses	2.84	2.30	2.96
	<b>Output capacity (kg/hr)</b>	<b>450.65</b>	<b>512.95</b>	<b>623.99</b>
15%	Shelling efficiency (%)	58.56	64.09	79.98
	Cleaning efficiency	93.54	93.42	95.86
	Grain Recovery efficiency	96.00	97.36	95.47
	Sheller Performance Index	89.79	90.95	91.52
	Total Grain Losses	2.53	1.91	2.99
	<b>Output capacity (kg/hr)</b>	<b>420.00</b>	<b>460.00</b>	<b>571.60</b>
17%	Shelling efficiency (%)	54.84	60.51	67.70
	Cleaning efficiency	93.29	94.24	94.27
	Grain Recovery efficiency	95.89	97.45	94.98
	Sheller Performance Index	89.45	91.84	89.54
	Total Grain Losses	2.23	1.74	5.57
	<b>Output capacity (kg/hr)</b>	<b>393.60</b>	<b>434.40</b>	<b>478.00</b>

### 3.1 Discussion

#### 3.1.1 Shelling Efficiency

From table 11, the shelling efficiency of the machine was found to increase as the speed of shelling increases (i.e. from 62.8% to 87.08%). Shelling efficiency reduces as the moisture content increase (i.e. 62.85% to 54.84%).

#### 3.1.2 Cleaning Efficiency

The cleaning efficiency was found to increase at increasing speed from 94.56% to 95.89%. The cleaning efficiency depends upon the rotation and the materials used in constructing the blower.

#### 3.1.3 Grain Recovery Efficiency

Grain Recovery Efficiency depends on the performance of the shelling drum and hopper. Table 11 shows that Grain Recovery Efficiency reduces as the moisture content of maize increases.

#### 3.1.4 Grain Loss

There is a reduction in Grain loss as the speed increases and the moisture content reduces.

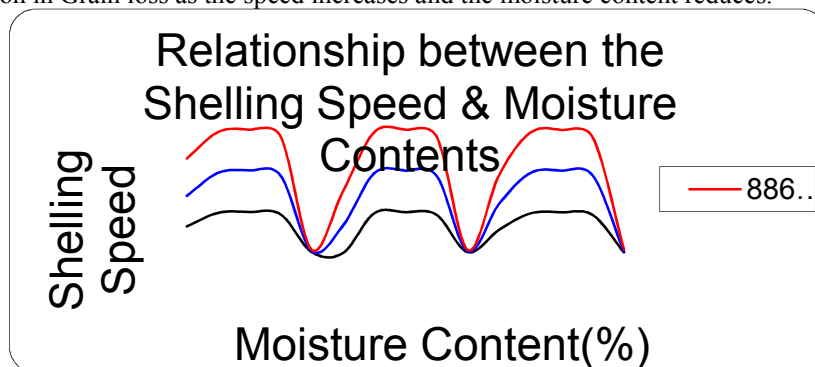

**Fig 12: The Curve of Shelling Speed against Moisture Content**

#### 3.1.5 Output Capacity

Table 11 shows that output capacity increases as the speed of shelling increases. The results obtained from the test are 450.65kg/hr, 512.95 kg/hr and 623.99 kg/hr at 623rpm, 823rpm and 886rpm respectively.

Also, the output capacity decreases as the moisture content of the maize increases (i.e. 450.65 kg/hr, 420.00 kg/hr and 393.60 kg/hr respectively at 13%, 15% and 17% moisture contents).

### 3.2 Interaction Effect between Shelling Speed and Moisture Content on Shelling Efficiency and Output Capacity

Fig. 16 (Graph) reveals that shelling efficiency increases as the shelling speed. The higher the shelling speed, the higher the efficiency.

Fig.17 (Chart) shows that output capacity of the machine increases with an increase in shelling speed.

Fig.16 (curve) reveals a decline in output capacity as the moisture content increases. The higher the moisture content of the maize used for shelling, the lower the output capacity.

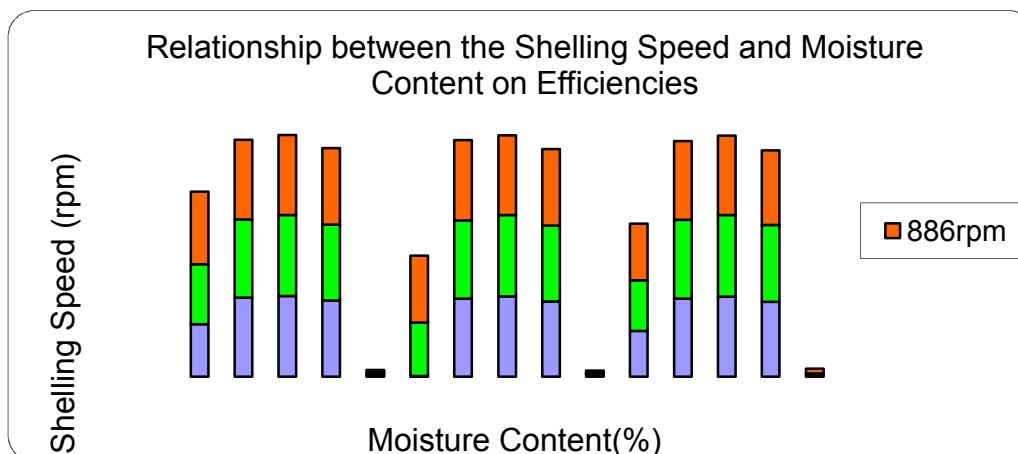

**Fig. 13: The Chart of Relationship between Shelling Speed and Moisture Content.**

Fig.16 (graph) shows that the higher the moisture content of maize, the lower the shelling efficiency of the machine.

Maize grains of higher moisture contents are not easily detached from the cobs by the rolling and crushing action of the spike teeth against the concave. Instead of shelling, maize grains of higher moisture content may be grinded or masticated. Hence, shelling efficiency is reduced by higher moisture content of maize.

The effect of shelling on both shelling efficiency and output capacity is directly proportional in relationship. The higher the shelling speed the higher the shelling efficiency and output capacity.

#### 4.0 CONCLUSION AND RECOMMENDATION

##### 4.1 Conclusion

Having tested the performance of the fabricated machine, it could be concluded that the shelling efficiency, cleaning efficiency, grain recovery efficiency, sheller performance index, total grain losses and output capacity are 87.08%, 95.89%, 95.48%, 91.55%, 2.96% and 623.99kg/hr respectively at 13% moisture contents of maize and at 886rpm shelling speed (Table 11, and fig16 and 17).

The best moisture content of maize for shelling according to this evaluation is 13% dry basis and the best shelling speed is 886rpm.

The machine is able to remove the tedious parts of operation involved in hand shelling and manually.

##### 4.2 Recommendation

On the completion of the machine and in spite of its effective performance, the following recommendations are therefore given for improvement.

- Addition of wheels to enhance the movement within shelling area and transportation from farms.
- Diesel engine (motor) can be incorporated to increase the efficiency of the machine.
- Moisture content of maize to be shelled should not exceed the range of 13% -14% dry basis for effective shelling and cleaning efficiency.

#### REFERENCES

- Abdullahi A.M, Kaul R.N. and Kalkat N.S. (1979): I A R Test report on DAE/97/7 Maize sheller. Department of Agricultural Engineering, Ahmadu Bello University, Zaria, Nigeria.
- Adebusuyi, J. (1983): Design and construction of a Maize sheller. Unpublished HND Thesis, I.A.R.&T, School of Agriculture, Ibadan.
- Adegbulugbe, A.J. (2007): Design and fabrication of a Maize sheller. B. Engineering Thesis (unpublished) Department of Agricultural Engineering, Federal University of Akure, Ondo State, Nigeria.
- Alao, S. (1996): Agricultural Engineers Handbook. Mc Graw Hill Book Company. New York Pp 253-258.

- Anderson, P. and Hez, T. (2000): General Review of grading machines Pp. 12-16. ww. Google.com.
- Apata, A. (1991): International Institute of Tropical Agriculture Recommended Cultural practices for food crops in Nigeria, P 20.
- ASHRAE (1998): ASHRAE Handbook, Grains American Society of Heating, Refrigeration and Air-Conditioning Engineers, Inc., SI Edition.
- Barkston, R. (1974): New development in field shelling of corn. Agricultural Engineering Journal, vol. 45. Pp. 484-500.
- Bikinski, J. and Hal, L. (1962): Aerodynamic properties of seed grains. Agricultural Engineering vol. 45. Pp. 484-485.
- Diestro, S.M. (1990): Operation, test and evaluation of IRRI Axial flow thresher, IRRI Training Course Journal P. 7.
- Eugene, A.A. and Theodore, B. (1986): Standard Handbook for Mechanical Engineering. McGraw Hill Book Company, P. 8-57.
- Griffin, G.A. (1973): Combine Harvesting fundamental of machine operation. John Deere Service Publication. Pp. 50-60.
- Hall, A. S., Hollowenko, A. R. and Laugh, H. G. (1983): Theory and Problems of Machine Design. Schaum's Outline Series. McGraw – Hill International Book Company. Singapore. Pp 113 - 130
- Harrison, H.P. (1999): Rotor Power and Losses of an Axial –flow combine. Transactions of ASAE 0001-2351/91/3406-0060, Pp 60-62.
- IITA (1996): International Institute of Tropical Agriculture (1996). Research Highlights for 1995 ISS No 331-4340. Pp. 52-53.
- Iwena, O.A. (2002): Essential Agricultural Science for Senior Secondary Schools. Fourth Edition Pp. 12-13.
- Kay, O.E. (1987): Root crops, second edition revised by E.G.B. Grooding, Crop and Product Digest No. 2. London, Tropical Development and Research Institute.
- Kenneth, J.S. and Kochar, R. (1988): Mechanical Engineering Handbook. John Wiley and Sons, P 1-58.
- Kochar R. and Kenneth J.S. (1988): Mechanical Engineering Handbook. John Wiley and Sons. Pp. 1-58.
- Kohl, I. and Fringes, B. (1998): General Review of Electric Motors P 10-13. www.google. com.
- Ladehinde M.A. (1988): Performance of grain threshing machine. Unpublished, annual report of NCAM, Ilorin, Kwara State, Nigeria.
- Lien R.M. and Haugh, G.G. (1975): Effect of shelling on popcorn quality. corn. Pp. 855 TASAE.
- Ndirika, V.I. (1995): Development and Evaluation of a millet thresher in Agricultural Engineering and Technology-volume 2, Pp. 80-89.
- NIS (1997): Nigerian Industrial Standard of Maize sheller Evaluation. Federal Ministry of Industries, Lagos. NIS 319:1997, Pp 6-8.
- Richey, C.B., Johnson, L. and Hall, C.W. (1982): Agricultural Engineering Handbook. McGraw Hill Book Company p. 650.
- Sandhar, N.S. and Panwar, J.S. (1994): Studies on machine crop variables influencing shelling of maize. Pp. 8-14. Indian Journal of Agriculture.
- Srinivas, J (2004): Comprehensive Handbook of Mechanical Engineering. Laxmi Publications Ltd. New Delhi - 110002. Pp 192 -195

The IISTE is a pioneer in the Open-Access hosting service and academic event management. The aim of the firm is Accelerating Global Knowledge Sharing.

More information about the firm can be found on the homepage:

<http://www.iiste.org>

### CALL FOR JOURNAL PAPERS

There are more than 30 peer-reviewed academic journals hosted under the hosting platform.

**Prospective authors of journals can find the submission instruction on the following page:** <http://www.iiste.org/journals/> All the journals articles are available online to the readers all over the world without financial, legal, or technical barriers other than those inseparable from gaining access to the internet itself. Paper version of the journals is also available upon request of readers and authors.

### MORE RESOURCES

Book publication information: <http://www.iiste.org/book/>

Academic conference: <http://www.iiste.org/conference/upcoming-conferences-call-for-paper/>

### IISTE Knowledge Sharing Partners

EBSCO, Index Copernicus, Ulrich's Periodicals Directory, JournalTOCS, PKP Open Archives Harvester, Bielefeld Academic Search Engine, Elektronische Zeitschriftenbibliothek EZB, Open J-Gate, OCLC WorldCat, Universe Digital Library, NewJour, Google Scholar

