

Introducing a Manipulated System of Drainage Basins of a Developing Countries

M. B. Yunusa

Department of Geography, Federal University of Technology, Minna, Nigeria

A. S. ABUBAKAR

Centre for Climate Change and Fresh Water Resources, Federal University of Technology, Minna, Nigeria.

Z.A.T. SULEYMAN

Department of Surveying and Geoinformatics, Federal University of Technology, Minna, Nigeria

M. Jibril

Department of Geography, Federal University of Technology, Minna, Nigeria

N. Abdulkadir

Abstract

As a natural open system, in a drainage basin, there is water flow and balanced channel characteristics. In a manipulated channel system, however, according to Mrowka (1974) and Schumm (1977), the water flow is made under control that induces dynamics in channel characteristics. In this paper, attempt is made to uncover how channel project is caused, nature of the new forms of channel cross-sectional area, shape, sinuosity, and gradient, as well as flood-plain characteristics. It also covers the peculiar transformation evolved as drainage basin system is changed to channel project. Consequently in the paper, two tasks involved were explained. These are significant channel re-construction, and redirection of stream flow as relates to developing water terrace in the savanna zone of Nigeria with the increased channel project dated back 1970s (Olofin, 1980). Specifically, the paper drew considered the physical characteristics of the natural channel of River Suka in North Central Nigeria and the manipulated system or the new face of the drainage basin project of the Kano River, Nigeria used to structure the Tiga dam that involved downstream channel adjustments

Keywords: drainage basin, channel, river, dam, downstream

Introduction

There is water flow and balanced channel characteristics in a drainage basin of a natural open system while natural water flow is made under certain control that induces dynamics in channel characteristics of the water flow by new control project or redirection that bring on some active changes in physical channel characteristics to form a manipulated channel system or channel project, as further explained in Mrowka (1974) and Schumm (1977). Under this, as channel project is caused, there are new forms of channel cross-sectional area, shape, sinuosity, and gradient, as well as flood-plain characteristics. The transformation of drainage basin system to channel project involves peculiar two tasks. These are significant channel re-construction, and redirection of stream flow. In the savanna zone of Nigeria since the 1970s (Olofin, 1980), the project had been on increase specifically in the control of the Kano River to form the Tiga dam that involved downstream channel adjustments.

In research, training and resource development, there are growing interests in adjustments of hydrological cycles, stream morphology and channel dynamics as detailed in works of Anderson, (1970), in changing channel morphology and hydraulic geometry of stream channels (Troxell and Leopold, 1971, Knox, 1977, Knight, 1979, Morisawa and Vemure, 1976, Morisawa and Laflurem, 1979, Ebisemiju, 1989). Efforts such as these simply constitute disturbed watershed resulting from both morphologic and hydraulic variable alteration (Simon, (1992), Simon and Hupp, (1992), Church, (1992), Pizzuto, (1994), and Elliot and Gyetuai, (1999).

To ensure judicious resource management, a new brand of environmentalism is needed for productive quality of the environment in Mikesell, (1974) and Mrowka, (1974) several ways in which man manipulates a drainage basin have been identified.

Literature Review

Alan (2002) used quantitative relationships describing the nature of surface drainage networks which have been used to formulate flood characteristics, sediment yield, and the evolution of basin morphology.

According to Leclair (2004), recent research on morphodynamic models for bedform-dominated rivers has strongly indicated the need to improve our knowledge of the nature of dune height and trough-scour depth variation in time and space.

Ways to manipulate drainage basins

Means to cause changes in drainage basins include mainly, direct channel alteration. By this way natural channel is altered directly through the construction of drainage system, bank treatment and irrigation. This way is relevant because there are linkages between the watershed characteristics and the stream at any point. By the alteration, changes are shown in the watershed attributes in the character of the stream flow and quality at all locations throughout the drainage basin. It is to be noted also that the effect generated could be marked by certain local factors which control relaxation time and input-output relationships. But the various ways in which man manipulates the natural channel, is by construction of drainage basin which has received a considerable attention because drainage system is considered as part of the most effective and desirable means of solving problems of erosion and flooding in watershed areas as enunciated in Edington, (1979).

Problems of losing natural drainage system for drainage project

In developing countries such as Nigeria, the prevailing situation downstream of urban rivers is not environmentally friendly. Continuous alteration of the morphology of the rivers downstream will lead to many environmental degradations, loss of the socio-economic importance of the river as such rivers serve as the modifier of the micro-climatic condition around its immediate environments. In these areas the water that is also used for dry season irrigation farming in the dry season downstream and equally for domestic activities such as construction of houses around its bank and excavation of sand will be redirected.

Consequentially, under the scenario, the drainage system upstream affects the downstream due to the induced high speed of the water from the upstream to the downstream location of the channel which has resulted in the distortion of the ecological balance. In the control of the effects, there are local efforts by the dwellers downstream of the channel to reduce the effect by using large stones and concrete reinforced materials to cover some of the areas affected by the artificial erosion activities. Other additional informal changes in the drainage such as soil excavation from the river bank during the dry season for use in house construction, causes destruction of the environment with negative effects on the drainage system. On causes of the serious environmental degradation, there is a grievous effect on the drainage system that aggravates solution to erosion and flooding.

Project approach in morphology manipulation

A system is a phenomena which are free to assume variable magnitudes that exhibit discernable relationship with one another and operate together as a complex as observed by some observed patterns such as (Chorley and Kennedy, 1971). One of the most commonly described systems is the global hydrological cycle, in which the movement and storage of water in its various forms are analyzed. Its various components such as rainfall, evapotranspiration, and runoff are functionally interrelated at a global scale. However, this global system can be sub divided into many similar subsystems and, thus, it is feasible and often useful to examine the hydrological balance within individual drainage basin or even for individual slope segments within a drainage basin. At an even more detailed local scale, an individual raindrop might be regarded as a system, with water being added and lost throughout its brief life, as a result of the inputs to and output from its local environment.

Therefore, a system is part of the physical world delineated in space and time, which is characterized not only by its objects and processes in isolation but by the nature of their interrelationship as a whole. The benefits of a system approach can be justified on several counts. Firstly, because the world is so complex and its components so closely interrelated, the study of isolated parts is very artificial and potentially misleading. A system approach provides a rational set of procedures for subdividing the environment into manageable functional parts and then investigating the relationship and between terrestrial and atmospheric system of the environment.

Secondly, a study of system stresses the relationship between components of the environment. The nature of such relationship is as important as the magnitude of individual attributes in characterizing and understanding the environment. Thirdly, the adoption of a systems approach is more likely to lead to the inclusion of all relevant variables and objects of importance. Thus, a system approach itself will facilitate the understanding of individual components of the environment; through knowledge of their interdependence with other components. Fourthly, through the objective definition of elements and variables within the systems, a quantitative approach is thereby encouraged. This is an essential precursor for a full understanding of the environment and consequently should be welcomed. Fifthly, deciding how the environment is going to change in the future is often an extremely difficult task and, consequently a system approach assists the formulation of such predictions.

Finally, for similar reasons to these predictions, the chances of assessing the repercussions of human activities are enhanced by a system approach. Consequently, in many circumstances, human activities have enhanced possibilities of controlling the environment to improve it uses and conserve its resources. One of the most important insights of the system approach is provided by the idea of feedback. This refers to the process by

which a change in one of the systems variables is transmitted through the system structure, so that eventually the effects are returned to the original variable.

In case of negative feedback, these effects tend to remove or tamper with the original variable and system that are consequently self regulating, for example, an animal population may increase temporarily for some reasons but on maturing, the animal will subsequently deplete the food supply and thus ultimately reduce the population to its previous level.

In positive feedback loops, reinforcement of trends is common, for example, removal of vegetation cover exposes the soil below and will often reduce the infiltration capacity, causing an increase in surface runoff which in turn increases slope erosion. If this erosion exposes less permeable soil, as is often the case, then infiltration capacity will be reduced yet further and will lead to even more slope erosion. Key regulator may cause positive or negative feedback mechanisms to be present and hence lead to completely different end result.

Inter-unit scarp of Natural River

The scarps slope toward the channel with characteristics of slope angles of the natural river particularly an urban river in Nigeria, the Tiga river located in North Central region, is specified as in figure 1.1, that in certain areas, the scarps are overcuts and made in slope profiles associated with the scarps and the gully sides in the upland areas of the river side. All the scarps, including the storm channel wall, are expected to recede backwards through gully processes as described by Ologe (1972) and Olofin (1978), thereby increasing the areal coverage of one land unit at the expense of the other and the rate of recession is not uniform. However, rates of 1.2metres at an average active gully-head area are common (Yunusa, 2006).

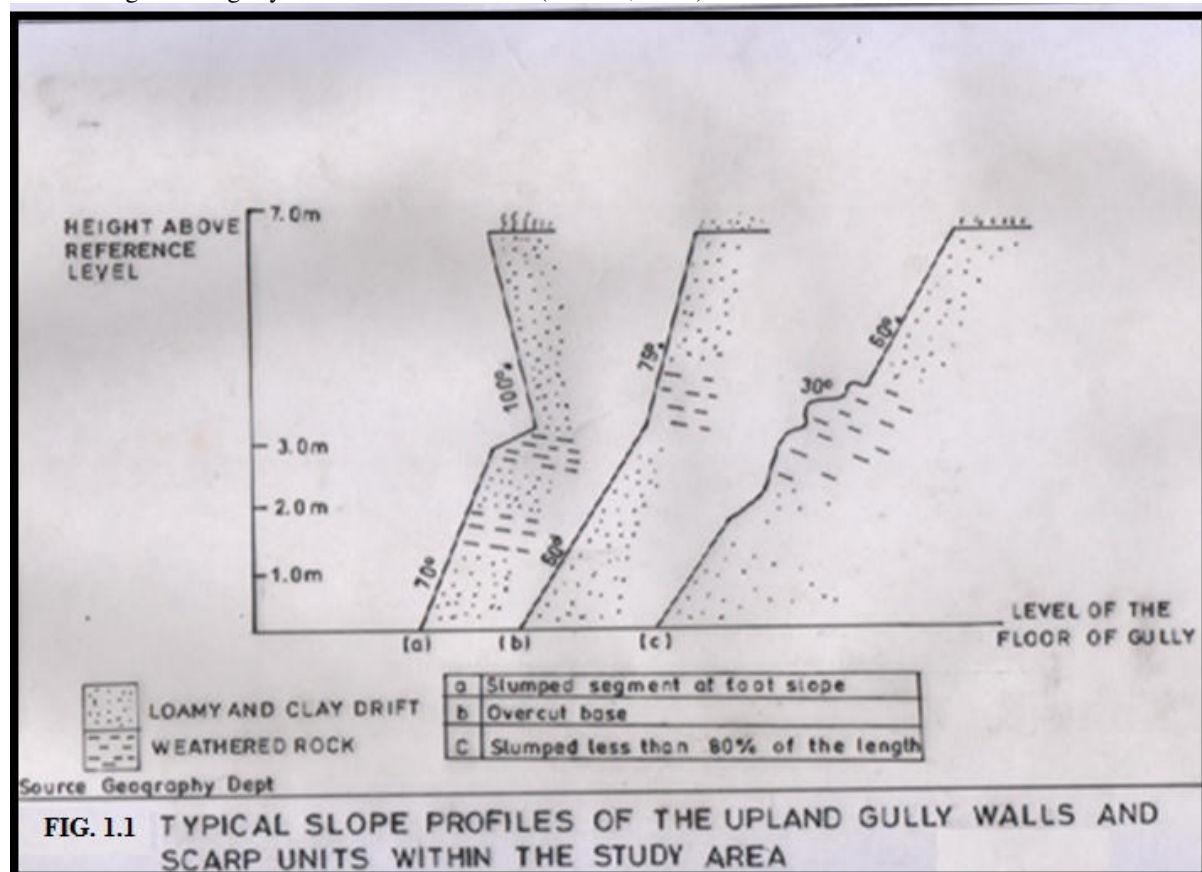

The channel system approach in River SUKA in north central Nigeria

The importance of system approach to physical geography is the medium it provides for quantification. The variables of any system can be isolated and measured to produce empirical data and the structure of any system can be quantified to show the interrelationship among its inputs and outputs, its storages, and its regulators and linkages. By studying the model of a system, one can determine fairly accurately, what change will occur if a particular variable is manipulated positively or negatively. For example, Figure 1.2 shows some valley side gully located on the nearest river (low) terrace to a stream channel into which the gully draws.

The stream channel shows the gully as a process-response system consisting of the actions and response between the rainfall runoff cascade and the morphological properties of the gully. The runoff cascade provides a link between the gully and the stream channel system. Four morphological systems are shown in the channel

system as upper valley-side gully, low terrace gully, gully-side slope and main channel in (Fig. 1.2).

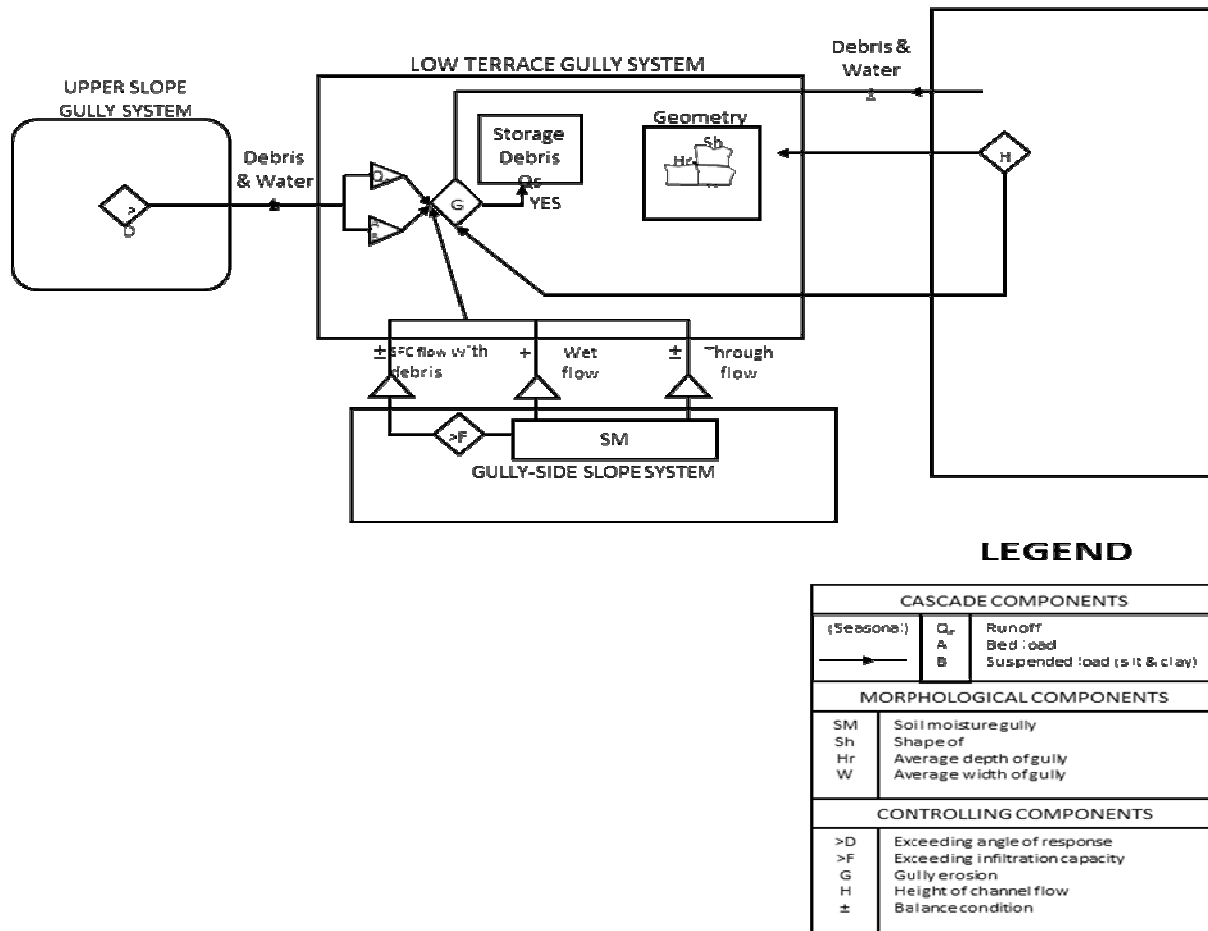

Figure 1.2 Model of the low terrace gully process of the Suka River for pre and post channelization
Source: Centre for Climate Change and Freshwater Resources, FUT, Minna, 2010

The cascades include rainfall runoff with its sediment load, through flow and stream discharge. The function of the upper valley-side gully is to pass energy and mass on to the low terrace gully when the angle of response (a regulatory variable) is exceeded. Both water and debris may remain relatively immobile at certain angle of response, but when the angle is exceeded, they will be on the move to the next system. The gully-side also allows energy and mass to pass on to low terrace gully on the surface, when infiltration capacity is low, as through flow or spring flow, when soil moisture (soil storage) exceeds the soil capacity. The function of the main channel is the regulator which provides in term of stage which regulates the level at which the output from the low terrace gully enters the main channel and decides whether the gully discharge should erode or deposit (store).

The low terrace gully is the principal system in figure 1.2. It is composed of the runoff cascade (Q), debris cascade and storage (Q_s and m), and geometric properties which include hydraulic ratios (H.R) or mean depth, width (w), and shape (Sh). Its internal regulatory components include the height of gully mouth above the bed of main channel (H_g) and the gradient of the gully floor which together with HR, determine the amount of erosion (GE), or of storage.

From the model, it can be confirmed that if the stage (HR) in the main channel system should make positive rise, the low terrace gully will be inundated as debris and water storages increase. Eventually, throughput the reduced negative change in output to the main channel as well as in output, the upper-valley-side gully and the gully-side slope system will be checked. Opposite reactions are to be expected if the stage showed fall, as it will downstream of channel.

Intent and targets of manipulated drainage system

The intent of any manipulated drainage system to cause changes and control the effects of channelized drainage system on natural channel morphology downstream of the natural River.

The targets are:

- a) To evaluate valley side slope with regard to soil erosion and sediment yield of channelized River system.
- b) To determine the effects of the changes in the cascading system due to erosion.
- c) To determine the effects of rainfall induced runoff at the downstream of the affected River and
- d) To determine the effects of human activities on the River downstream.

Maria, (2007) analyzed various morphometric characteristics of the Colangiül river basin in order to evaluate the flash flood hazards. Such high-water events pose a risk to the similarly named small village located at the basin's foot area.

Conclusion

In conclusion and with respect to the specifics of both natural and manipulated river channel characteristics discussed above, the following settlements should be made on the affected (natural) river.

1. There should be adequate information on study area (geographical) location, the area the river movement direction, the area river and channel geographical boundaries as well as natural resource characteristics. Equally, there should information on climate of the river area in respects of amount of rainfall, at least five years water flow discharges, as well as knowledge of the natural erosion process of the river. Erosion history of the affected river, land use pattern of the area, economic importance of the river and uses are also required.
2. Also, there is the need to know the geology of the area in respects of river underlying complex, rocks, and soil. Useful information is the nature of the vegetation of the area including shrubs in the surroundings, forestry, trees, et cetera. The relief characteristics of the area are required in respect of the three-dimensional quality of the surface, and the identification of specific landforms. There is strong need to acquaint with the soils of the area resulting from the interaction between the climate, flora and fauna, parent material and geomorphic factors that occur over varying period of time. They are, therefore developed from the Precambrian basement complex rock comprising granite schist, gneiss and amphiboles. Since the river channel is hydrological, there is the strng need to know some facts about the hydrological history of the river.
3. Most importantly, the specific fact is required about the river channel. These include: the volume of water in the river, its controlling situations, the amount of water or rainwater that infiltrates into the ground that depends on the topography.

Recommendation(s)

There should be appraisal of the effects the human manipulation of a drainage basin could have on the stability of climatic variables which pre-exist between the variables of land and that of water in an affected basin.

Acknowledgement

The authors will like to acknowledged Mr. J.O Omotayo, of Cartography Section of Department of Geography, Federal University of Technology Minna for providing the map and field exercises.

REFERENCES

- Anderson, D. G. (1970) Effect of Urban Development of floods in Northern Nigeria. US Geological Survey: Water Supply paper, pp 22
- Chorley, R. J. and Kennedy, B. A. (1971). Physical Geography: A system Approach, London, Prentice-Hall, particularly Chapter 1.
- Church, M. (1992) Channel morphology and topology, pp 126-143, In The River Handbook, vol. I. P. Clarlow and G. E. Petts (Eds). Blackswell, Oxford.
- Ebisemiju, S. F. (1989) The response of head water channels to urbanization in the humid tropics *Hydrological Processes* 3, 237-253;.
- Edington, J. M. and Edington, M. A. (1979) *Ecology and Environmental planning*, London, Chapman and Hall, particularly Chapter 5, 78-109.
- Elliot, J. G. and Gyrtvai, S. (1999) Channel pattern adjustment and geomorphic characteristics of Ekhead Creek, Colorado, 1939-1997, *US geological Survey Water Resources Investigations, Report 99-4098*, U. S. Government Printing Office, Denver Colorado.
- Knight, C. (1979) Urbanization and natural stream channel, *Annals Association of American Geographers* 67(3): 323-342.
- Knox, J. C. (1977) Human impacts on Wisconsin stream channels. *Annals Association of American Geographers* 67(3): 323-342.
- Mikessell, M. W. (1974) Geography as the study of environment: an assessment of some old and new commitments, In: Manners and Mikesell (eds.), *Perspectives on Environment, Essays Association*.

- America Geographers, No. 13, 1-23.
- Morisawa, M. G. and Vemure, R. (1976) Multi-objective planning and environmental evaluation of water resources systems: Final Report Project C-6065, US department of the interior, OWRTP, 1-99.
- Morisawa, M. E. and Laflurem, G. (1979) *Stream Channel Response to Urbanization: The case of Ikpoba River, Benin City, Nigeria.*
- Mrowka, J. P. (1974). Man's impact on stream regime quality: Manners and Mikesell (Eds), *Perspectives on Environment*, pp. 79-104.
- Olofin, E. A. (1978) Gullies and farmland Resources in part of the River Chalawa Basin, paper presented at the 19th annual Conference of the Nigerian Geological Association, A. B. U. Zaria.
- Olofin, E. A. (1980) effects of gully processes on farmlands in the Savannah areas of Nigeria-Chalawa Basin Case Study, *Kano Studies*, Vol. NS1 (3), 74-83.
- Ologe, K. O. (1972) Gullies in Zaria area: A preliminary study of headscarp recession, *Savanna*, Vol. 2(1), 68-74.
- Pizzuto, J. E. (1994) Channel adjustment to changing discharges. Powder River. Montana. *Geological Survey of American Bulletin*, 106: 1494-1501.
- Schumm, S. A. (1977). *The Fluvial System*, New York, Wiley.
- Simon, A. (1992) Energy time and channel evolution in catastrophically distributed fluvial systems. In: *geomorphology*, M. E. Morisawa (Eds) Elsevier Science Publisher, Amsterdam.
- Simon, A. and Happ, C. P. (1992) Geomorphic and vegetative recovery processes along modified Tennessee streams: an interdisciplinary approach to disturbed fluvial systems, *Proceedings of the Forest Hydrology and Watershed Management Symposium*, Vancouver, August 1992, Publication No. 167:251-261.
- Yunusa, M. B. (2006) Typical Slope Profile of the Upland Gully Walls and Scarp units within River Suka.

The IISTE is a pioneer in the Open-Access hosting service and academic event management. The aim of the firm is Accelerating Global Knowledge Sharing.

More information about the firm can be found on the homepage:

<http://www.iiste.org>

CALL FOR JOURNAL PAPERS

There are more than 30 peer-reviewed academic journals hosted under the hosting platform.

Prospective authors of journals can find the submission instruction on the following page: <http://www.iiste.org/journals/> All the journals articles are available online to the readers all over the world without financial, legal, or technical barriers other than those inseparable from gaining access to the internet itself. Paper version of the journals is also available upon request of readers and authors.

MORE RESOURCES

Book publication information: <http://www.iiste.org/book/>

Academic conference: <http://www.iiste.org/conference/upcoming-conferences-call-for-paper/>

IISTE Knowledge Sharing Partners

EBSCO, Index Copernicus, Ulrich's Periodicals Directory, JournalTOCS, PKP Open Archives Harvester, Bielefeld Academic Search Engine, Elektronische Zeitschriftenbibliothek EZB, Open J-Gate, OCLC WorldCat, Universe Digital Library, NewJour, Google Scholar

