

## Developmental performance appraisal and organizational citizenship behavior: testing a mediation model

Ali Poursafar\*<sup>1</sup>, Saeed Rajaeepour<sup>2</sup>, Sayeed Ali Seyadat<sup>3</sup>, Hamid Reza Oreizi<sup>4</sup>

1. PhD student in Educational Administration, University of Isfahan.
2. Associate professor of Educational Administration, University of Isfahan.
3. Associate professor of Educational Administration, University of Isfahan.
4. Associate professor of Psychology, university of Isfahan

\*Corresponding author. Email: ali.poursafar@yahoo.com

### Abstract:

The goal of the present research was to examine how organizational support and organizational commitment influence the relationship between developmental performance appraisal and the employees' Organizational Citizenship Behavior. A number of 217 formal employees working at Gas Company in Gilan, Iran with a degree of diploma and beyond were selected to answer a questionnaire in a stratified random manner. The research method was a cross-sectional survey type (structural equation model). Research instruments adopted in this study included Questionnaire of Developmental Performance Appraisal (Kuvaas, 2007), perceived Organizational Support scale (Rhoades, Eisenberger and Armeli, 2001), Organizational Commitment Questionnaire (Balfour and Wechsler, 1996), as well as Organizational Citizenship Behavior (OCB) Questionnaire (Lee and Allen's, 2002). To evaluate the suggested model, structural equation modeling through PASW Statistics22 and Amos Graphics21 software were utilized. Moreover, the indirect effects were tested by Bootstrap procedure. The results revealed that the research suggested model enjoyed a good fitting with data. The findings does not support direct path of developmental performance appraisal on OCB. The research findings showed that indirect path of developmental performance appraisal, organizational commitment and organizational citizenship behavior was meaningful, while the indirect path of developmental performance appraisal, organizational support and organizational citizenship behavior were not supported. Eventually, Implications and directions for future research are discussed.

**Keywords:** *Developmental performance appraisal, organizational support, organizational commitment, Organizational Citizenship Behavior, mediation model*

### 1. Introduction:

During recent years, researchers of human resources have conducted numerous studies regarding the relationship between human resource management (HRM) practices and outcomes at the level of individuals, employees' perception of effects of human resource systems on their attitudes and behaviors (Kuvaas, 2007; Kehoe & Wright, 2013; Trumbly et al. 2010; Alfez et.al. 2013). Because of the strategic importance of human resource development and the strategic role of alignment among employees' knowledge, capabilities and skills as a competitive advantage source (Toracco & Swanson, 1995), the effects of developmental human resource (HR) practices on employees' organizational citizenship behavior (OCB) have been examined in the present research. In this paper, we are concerned with the relationship between Developmental performance appraisal (PA) and employees' OCB. We examine the effects of developmental performance appraisal that enhances employees' OCB by providing greater organizational support and organizational commitment. We also used social exchange theory for understanding the relationship between Developmental PA and employees' OCB and to suggestions that organizational support and organizational commitment may be a significant element in the link between Developmental PA and OCB. So that it can contributes to a further understanding of the antecedents of OCBs.

### Influence of developmental performance appraisal on organizational citizenship behavior

Despite considerable advances in recent years in our understanding of how human resource management (HRM) might be linked with favorable individual and organizational level outcomes (Alfez et. al.2013; Huselid,1995; Wright et .al.,2005; Delaney&Huselid,1996; Becker & Gerhart,1996), More recently, however, scholars examines individual level outcomes namely employee perceptions of an organization's HRM system, as employee perceptions of HRM practices may be predictors of individual attitudes and behaviors. This is because the way employees experience or perceive their employers' HRM strategies influences their attitudes and behaviors (Alfez et. al.2013).

Performance appraisal (PA) is often considered one of the most important developmental human resource practices that its use is very widespread today (Boswell & Boudreau, 2000; Levy& Wiliams, 2004). Performance

appraisal has been defined as a process of identification, assessment and development of individuals' performances for achieving individual and organizational goals (Dessler, 2007). A majority of researchers and authors have suggested two major aims to employees' performances appraisal; the first of which is administrative which is performed to assess their performances for making such decisions as allocating reward, increasing salary, giving a job promotion, transmission or decreasing their ranks. The second goal is developmental by which the employees' strong and weak points' determined, an opportunity for performance feedback is created for them and eventually an exchange with administrators is facilitated (Cleveland & Murphy and Williams, 1989; Tziner, Joanis and Murphy, 2000; Rayan, Gerhart & Park, 2000). The ultimate goal of performance appraisal is to improve performance at the level of individuals and organizations consequently (Bohlander, Sherman & Snell, 2000; Rayan, Gerhart & Park, 2005).

With the importance of performance appraisal given, several organizations have declared their dissatisfaction with the existing performance appraisal system and hold the view that a majority of performance appraisal systems fail to create motivation among employees not leading them through development (Fletcher, 2001, 2002; Kuvaas, 2007). In Felcher's view (2001), such feeling of discontent may serve that performance appraisal system had failed to be as a mechanism for individuals' improvement. One crucial factor in illustrating the issue is that performance appraisal systems overemphasize the evaluating aspect (administrative application) of evaluation, underestimating their developmental applications. Consequently, the research trend and implementation of performance appraisal has moved away from evaluation and psychometrics issues toward motivational and developmental themes (Levy & Williams, 2004; Kuvaas, 2007; Felcher, 2001; Milward, 2005).

In spite of the fact that individuals' performance improvement and development is considered as an important goal of performance appraisal (Bohlander, Sherman & Snell, 2000; Rayan, Gerhart & Park, 2005; Youngcourt and et al. 2007; Kuvaas, 2007), few research has been conducted regarding developmental performance appraisal (PA) which results in individuals' motivation and improvement (Felcher, 2001; Boswell W R., Boudreau, 2002; Kuvaas, 2007). Developmental PA is related to any attempt made to improve individuals' attitudes, experiences and skills leading to their performance improvement and potentially creates motivation and commitment at the workplace (Kuvaas, 2007). Robert & Reed (1996) have introduced three components for developmental PA involving goal-setting, participation and performance feedback. Goal-setting refers to the extent to which employees perceive their performance goals as being clear, challenging, relevant and understandable. Performance feedback refers to the extent to which employees experience appreciation for performance feedback being perceived as clear, relevant and understandable. These perceptions represent some of the most important underlying mechanisms used to explain how goal setting and feedback, which are key developmental PA activities in organizations, can develop employee motivation, commitment, performance and OCB (Kuvaas, 2007).

Numerous researches have been conducted on the potential role of developmental PA in employees' attitude and performance improvement. Regarding this, a meta-analysis study has been done by Jawahar & Williams (1997), in which they examined data collected from a number of 22 studies and found that administrative appraisal was done more lenient than developmental appraisal, with the first as having less precision. Almost 70% of the participants in the study done by Cleveland and et al. (1989) asserted that the appraisal made with a goal of developmental application exerted more influence. As a matter of fact, many of the respondents preferred developmental usage such as career planning, education and development over administrative usage. Similarly, Dipboye, & de Pontbriand (1981) showed that employees accept appraisal system and feel satisfied with it when it emphasizes their development and performance improvement. Based on Boswell & Boudreau (2000, 2002), whenever the developmental goals of performance appraisal are emphasized, employees' feelings will be improved in order to do appraisal. Moreover, the research done regarding 360°-degree appraisal has shown that the appraisal made with an aim of development has been considered as more positive from the participants' perspectives. On the basis of theory and research regarding performance appraisal, the developmental component of performance appraisal is regarded as a positive predictor of satisfaction with performance appraisal (Cleveland et al. 1989, Pettijohn. and d'Amico, 2001). Thus, in theory, developmental performance appraisal fulfils employee needs and therefore generates favorable attitudes and that result in job behaviors. From the viewpoint of the authorities, whenever employees accept appraisal system, feel satisfied with it and performance appraisal process is accurately implemented, such system will influence their development and performance improvement (Kuvaas, 2007; Pettijohn. and d'Amico, 2001; Boswell & Boudreau, 2000). On the basis of the issues mentioned above, the following research hypothesis can be stated:

**Hypothesis 1:** *Perceived developmental performance appraisal is positively related to organizational citizenship behavior.*

## **The mediating influence of organizational support and organizational commitment in relationship among developmental performance appraisal and OCB.**

Although empirical findings have generally supported the notion that HRM practices are associated with positive individual and organizational outcomes, more recently commentators have sought to explore the mechanism through which HRM practices are linked to individual and organizational outcomes. Moreover, the theoretical model that depicts the relationship between HRM practices and performance introduced by Guest (1997) suggests that employee perceptions of HRM practices lead to outcomes which are attitudinal, which in turn lead to behavioral outcomes such as OCB and performance (Alfez et. al.2013).As mentioned, Guest (1997) suggested that attitudinal variables link HRM practices with employee behaviors. Two such attitudinal variables that have been explored in the extant literature are organizational commitment and organizational support.

Perceived organizational support (POS) refers to employees' perception of the organizations' commitment to them and reflects their beliefs about the extent to which the organizations value their contributions and care about their well-being (Eisenberger et. al., 1986). Social exchange theory suggests that workers who perceive a high level of organizational support will feel an obligation to repay the organization through positive attitudes and appropriate behaviors (Eisenberger et. al., 1990). Previous research suggests that perceived organizational support can mediate the relationship between human resource management practice and work performance.

Allen and et al. (2003) and Meyer & Smith (2000) supported the mediation role of organizational support in the relationship between human resource management practice and organizational commitment. However, Snap & Rodman (2010) failed to represent any evidence on the mediatory effect of organizational support in the relationship among human resource management practice, citizenship behavior and performance. Wayne et al. (1997) found the positive relationship both between promotion and developmental experiences and discussed that developmental opportunities are signs of the fact that organizations value workers' contributions. A developmental HR practices may be viewed as signaling intent for long-term investment in employees that obligates them to respond with discretionary role behavior (Sun, Aryee, Law, 2007 and Alfez et. al.2013). Eventually, on the basis of a meta-analysis study, Rhoades, Eisenberger and Armeli (2001) supported the relationship between human resource management practice and perceived organizational support. They also support a positive relationship between POS and different measures of performance .Consequently, the following hypothesis can be made:

***Hypothesis 2: the relationship between perceptions of developmental performance appraisal and organizational citizenship behavior is mediated by POS.***

A common agreement existed in the literature of organizational commitment is that a high level of performance and productivity is achieved whenever workers are committed to their organizations, feel proud of the organization members and believe in the organization's values and goals (Balfour and Wechsler, 1990). Such viewpoint has been expressed on the basis of Social Exchange Theory. It is argued that employees gain advantage from organizations, they feel committed to repay for it and attempt to compensate for the benefits gained from organizations (Kuvaas, 2008).

Several studies have supported the positive relationship between human resource management practice and organizational commitment (Meyer et. al.1989; Meyer & Smith, 2000; Paul &Ananteraman, 2004; Rikita, 2002). For instance, Kehoe & Wright (2010) found that affective organizational commitment partially mediates the relationship between human resource management practice and citizenship behavior. While, Kuvaas (2008) failed to provide necessary experimental support for the relationship among developmental human resource management practices, turnover intention and work performance with their being mediated by affective commitment. Meyer & Smith (2000) made an attempt to examine the relationship between developmental human resource management practice (e.g. training &performance evaluation and career development) and organizational commitment showed that developmental human resource management practice was meaningfully correlated with normative and affective commitment, while there was no meaningful relationship between continuance commitment and developmental human resource management practice.

On the other hand, research has shown that high levels of organizational commitment is correlated with such positive outcomes as job satisfaction, work performance, higher motivation and a less tendency to leave work. Somers & Birnbaum (1998) revealed that affective commitment was positively correlated with task performance while there was a negative relationship between continuance commitment and task performance. Balfour and Wechsler (1991) attempted to examine antecedents and outcomes of organizational commitment (performance

and productivity). The results showed that there was a positive relationship between identification, internalized commitment and in-role behaviors. Generally, previous research shows that developmental performance appraisal, both directly and through some attitudinal variables involving organizational commitment as well influence employees' task performance. Consequently, the following hypothesis can be developed:

**Hypothesis 3:** *The relationship between perceptions of developmental performance appraisal and organizational citizenship behavior is mediated by organizational commitment.*

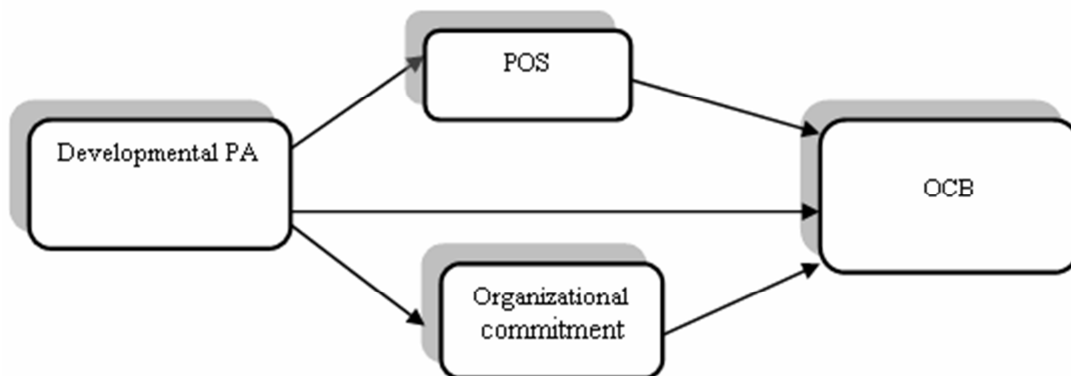

Figure 1: research conceptual model

## 2. Research methodology:

Regarding its applied goal and concerning data collection method, the present research was a cross-sectional survey and of structural equation model type (Sarmad, Bazarghan & Hejazi, 1997). The research variables included developmental performance appraisal as an independent variable, task performance and citizenship behavior as dependent variables as well as organizational support and commitment as mediation variables. The statistical population involved all formal employees working at Gas company in Gilan province, Iran who were selected using stratified random sampling method (being proportional to sample size) held diploma degree and beyond. The sample size was estimated to 240 employees using the Cochran's sampling formula. To reach more confidence, a number of 250 questionnaires were distributed, among which a number of 217 questionnaires completed by research participants were collected, with the questionnaire return rate being .87.

### 2.1. Measures

**Developmental performance appraisal:** Perceptions of Developmental performance appraisal were measured with a ten item scale by Kuvaas (2007). The alpha reliability coefficient for scores on these items was .94. Two sample item were "Provides me with information about organizational goals? Feedback I receive agrees with what I have actually achieved?" The respondents used a 5-point Likert-type scale to indicate their agreement (1 = *strongly disagree* and 5 = *strongly agree*) with each of the items in these scales ( $\alpha = .93$ ).

**Perceived organizational support (POS):** Employees completed a short version of Perceived Organizational Support scale (Rhoades, Eisenberger and Armeli, 2001). We used the eight items of the POS scale. Employees indicated their degree of agreement to these items on seven-point ranging from "strongly disagree" (1) to "strongly agree" (5) ( $\alpha = .83$ ).

**Organizational Commitment:** Organizational commitment was measured using the six item OCS developed by Balfour and Wechsler (1996). Example items include "What this organization stands for is important to me" and "I feel like 'part of the family' at this organization." The respondents used a 5-point Likert-type scale to indicate their agreement (1 = *strongly disagree* and 5 = *strongly agree*) with each of the items in these scales ( $\alpha = .84$ ).

**OCB.** Supervisors also completed the 16-item measure of OCB published by Lee and Allen (2002), indicating the extent to which they agreed with statements about their subordinates' behavior. The respondents used a 5-point Likert-type scale to indicate their agreement (1 = *strongly disagree* and 5 = *strongly agree*) with each of the items in these scales ( $\alpha = .84$ ).

### 2.2. Data analysis strategy:

To assess the research suggested model, the structural equation model and Maximum Likelihood method via PASW statistic<sub>22</sub> as well as Amos Graphics<sub>21</sub> software package were used. To determine the fit between the suggested model and collected data, such as fit goodness indices as Chi square, CMIN/DF, CFA, GFA, TLI, IFI

& RMSEA were used. In order Mediation Effects testing regarding, Bootstrap procedure together with Preacher & Hayes' (2004) Macro Program were adopted.

### 3. Research findings:

Mean and standard deviation and correlation coefficients among variables were calculated via PASW statistics 22 software package, the results of which have been shown in table 1. Mean and standard deviation scores for the Variables were obtained, respectively as follow:

Table 1: Means, Standard Deviations, Correlation Matrix of Variables

Variables	Mean	SD	1	2	3	4
1- Developmental performance appraisal	3.68	0.69	-			
2- Perceived organizational support	3.1	0.64	0.56**	-		
3- Organizational Commitment	3.8	0.68	0.61**	0.62**	-	
4-OCB	4	0.60*	0.09	0.15*	0.16*	-
P <0.01/ **      P <0.05 *						

The above table showed that developmental performance appraisal was positively and meaningfully correlated with employee organizational support and commitment, while it had a positive and non-significant relationship with employee citizenship behavior. Moreover, organizational support and commitment had a positive & significant relationship with citizenship behavior.

Table 2: fitness indices of research suggested models

Model	X <sup>2</sup>	df	X <sup>2</sup> / df	CFA	GFI	NFI	TLI	IFI	RMSEA
Structural Model	5.8	5	1.16	0.99	0.96	0.98	0.99	0.99	0.02

To evaluate the research suggested model, the structural equation model together with Amos Graphics21 software package were used. Indices of fitness between the suggested models and data have been reported in table 2. Concerning the research suggested model, the ratio of Chi square over degree of freedom was lower 3. The extent of RMSEA was obtained less than 0.1. The extent of the indices GF, NFI, IFI & CFI were obtained near 1.

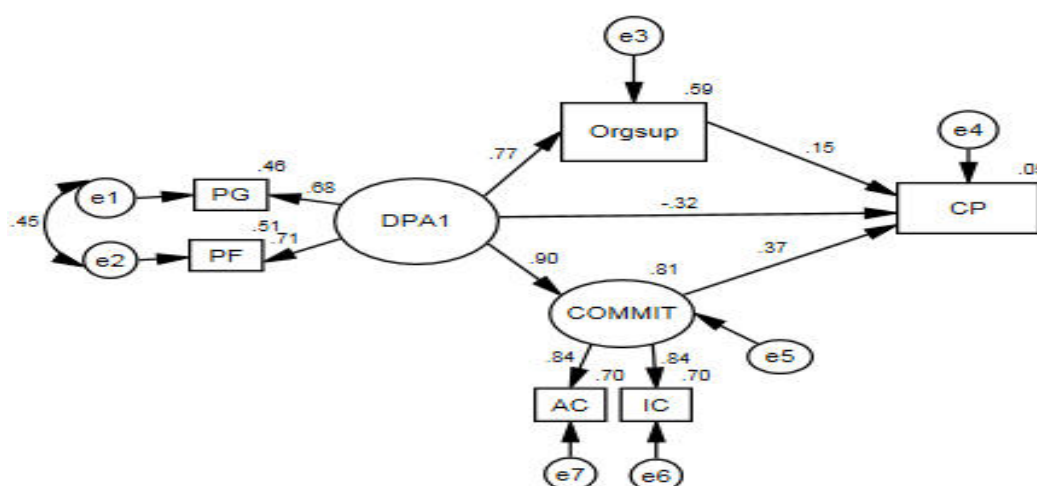

Figure 2: Path Coefficients in the research suggested model

Path coefficients in figure 2 represent a confirmation of the direct paths of developmental performance appraisal with organizational support and organizational commitment as well as the path of organizational support and commitment towards employees' citizenship behavior. However, such coefficients reject the direct paths among

developmental performance appraisal, citizenship behavior. Figure 2 shows the path coefficients in the research suggested model. To test indirect effects and to determine the significance, Bootstrap procedure (Preacher & Hayes', 2004 and 2008) was used. Results of indirect effects have been presented in table 5.

Table 3: Results of Bootstrap Test for analysis of indirect effects

Paths	Confidence Intervals		SE	Bias	boot	Data
	Lower	Upper				
Developmental PA → POS →OCB	- 0.04	0.15	0.04	- 0.0 01	0.07	0.07
Developmental PA → commitment →OCB	0.06	0.18	0.04	0.0009	0.09	0.09

The confidence interval for the first paths in table 3 represent the existence of zero at this interval, thus rejecting the indirect relationships in these paths(Developmental PA to POS and OCB). While the confidence interval for the path (developmental performance appraisal to organizational commitment and OCB) in table 3 represents non-existence of zero, thus confirming the indirect path. Regarding this interval, the confidence level was 0.95, with the number of resampling being as 5000.

#### 4. Results:

Several models of human resources management practices suggest that such practices exert their influences on employees' behaviors and performances through affecting their attitudes (Bagozi, 1992; Guest, 1997, Alfez et. al.2013). In order for performance appraisal (PA) to positively influence employee behavior and future development, employees must experience positive appraisal reactions (Cleveland, and Murphy 1995, Kuvaas, 2007). Thus, there is general consensus among PA researchers and practitioners that assessment of appraisal reactions is important (Keeping and Levy, 2000). The present research was conducted with an aim of examining the mediation role of organizational support and organizational commitment in the relationship between developmental performance appraisal and OCB among Gas company employees in Gilan, Iran. The research findings supported the mediation role of organizational commitment in the relationship between developmental performance appraisal and citizenship behavior. Such research results were congruent with those of done by Yung (2012), in which the mediation role of affective commitment in the relationship between human resource management practices and employees' citizenship behavior was examined. Thus, it is suggested that, in order to develop citizenship at organizations, the policy-makers should implement developmental performance appraisal in such a way that it can increase employees' organizational commitment in the favor of organizations. While the research findings did not support the mediation role of organizational support in the relationship between developmental performance appraisal and OCB. These findings were congruent with those of done by Kuvaas (Kuvass, 2007; Kuvaas, 2008). Non-existence of the mediation relationship may be due to lack of any significant relationship between developmental performance appraisal and employee OCB (returning to table 1: the non-significant relationship in the two-variable correlation matrix and figure 2: negative path coefficients in the research suggested model).

In explaining why no direct, significant correlation was obtained between developmental performance appraisal and employees OCB, Kuvaas (2007) asserted that employees, with a strong autonomy orientation and an internal locus of control are less affected by external interventions such as goal setting and appraisal feedback. From his perspective, whenever employees experience performance appraisal as a controller, which in turn could have undermined their need for autonomy and therefore adversely affected Performance. Since autonomy orientation is the strongest predictor of performance, those employees with a high performance level may assume that a great amount of time and energy is requested for providing understandable, relevant and clear goals and feedback; thus, they may negatively react to it. Based on Kuvaas(2007), the findings express that developmental PA exerts a negative influence on the employees with the best performers, which may be particularly critical for knowledge-based organizations with few management levels and high levels of autonomy for individual employees.

In addition, some reasons can be stated in clarifying the lack of the relationship between developmental performance appraisal and employee OCB in the present research. First, at the time of judging others' performances, people make

use of some mental judgments which are not free from bias in nature (Spector, 2002; Decenzo and Robbins, 1996). Regarding that the supervisors gave all employees' performances high scores (refer to the mean and standard deviation of work performance in table 1), these results can be illustrated on the basis of Leniency Error Theory (Tziner & Murphy, 1999). Based on this theory, evaluators tend to give all individuals desirable scores. Moreover, since employees' performance appraisal causes some conflict and opposition between administrators and employees, leading to the employees' exhibiting some deviant behaviors, supervisors treat them leniently, giving them high scores in order to prevent such conflicts (Spector, 2002; Decenzo and Robbins, 1996). Along with this issue, approximately 90 years ago, Thorndike (1920 cited in Mount et.al.1998) observed that whenever administrators evaluate their employees' performances, the correlation between dimensions of work performance was higher than what was in reality. The studies conducted on this issue have shown that the effects of performance appraisal method are one of the most major sources of error in rating performances.

Moreover, such results can be clarified on the basis of Arvey and Murphy viewpoints (1998) regarding the effects of context and backgrounds on rating of employee performance. They suggest that researchers should pay attention to the context of performance appraisal before analyzing the efficacy and accuracy of rating employee performance. Considering performance appraisal as a goal-oriented behavior, they assert that in case the goals followed by evaluators are thoroughly scrutinized, it will be clarified that the behaviors exhibited as rating errors (giving high scores to a majority of employees) are often developed as an adaptive reaction by administrators against the pressure exerted by the existing forces in the rating environment. With this token, no study can provide firm evidence regarding such statements. However, such interpretations should be more carefully examined in future research on performance appraisal. While the mediatory relationship among variables was not supported, such implications encourage us to continually examine employee attitudes in the relationship between developmental performance appraisal and employees' work performance.

With regard to the results obtained in this study and with the direct relationship among developmental performance appraisal and employees' OCB not being supported, it seems that despite the fact that several theories have introduced developmental performance appraisal and its dimensions as some crucial factors in influencing employees' performances in organizations, regarding the statistical sample examined in this research, developmental performance appraisal has failed to be a determiner of employees' OCB. Regarding the theoretical framework discussed in the present research, it is suggested that, in addition to performance rating done by supervisors, employees' performances be evaluated through colleagues' ratings as well as self-report, thus their results can be compared.

Just as other studies, this research has some limitations. The first limitation is that in this research, self-report questionnaires have been used for assessment of developmental performance appraisal as well as organizational commitment, and regarding that one natural feature of such questionnaires is respondents' idea reflection and their personal perceptions of questions, their ideas may not completely express reality about them (Podsakoff & Organ, 1986; Donaldson & Grant-Vallone, 2002). Moreover, concerning rating employee performance, as explained before, it seems that managers are not qualified enough to evaluate employee performance. Accordingly, future research should take such limitations into account in an appropriate way. Seemingly, the above-mentioned limitations can be eliminated to some extent through teaching managers how to treat errors that occur in evaluating employee performance and to make use of multiple rating (self-report, administrators & colleagues).

One other limitation of the present research is that, concerning research methodology (it's being cross-sectional), the model confirmed is a correlational model. Thus, inferring causal relationship, similar to what is existed in experimental research, is not logical. Hence, experimental studies were needed to examine causality regarding the relationships under study in this research. Other limitation was that the majority of sample group included men. Thus, different results may be reached in female groups. As explained in review section, several factors influence employee work performance; however, in the present research, developmental performance appraisal has been solely examined regarding the mediatory role of organizational support and commitment, and other factors involving personality traits, management and leadership characteristics or situation, with its playing a role in emergence of employees' work performance, have been ignored in this research. In future research, the relationship between performance appraisal system and employee work performance regarding the influence of such elements as attitudinal, cognitive and motivational variables can be examined so that one can reach a better recognition of how to create conditions essential for emerging task performance as well as citizenship behavior among employees.

## 5. Reference:

- Alfes, K., Shantz, A., Truss, C., & Soane, E. (2013). The link between perceived human resource management practices, engagement and employee behaviour: a moderated mediation model. *The international journal of human resource management*, 24(2), 330-351.
- Allen, D., Shore, L., Griffeth, R. (2003). The Role of Perceived Organizational Support and Supportive Human Resource Practices in the Turnover Process, *Journal of Management*, 29(1):99–118.
- Arvey, R. D., & Murphy, K. R. (1998). Performance evaluation in work settings. *Annual review of psychology*, 49(1), 141-168.
- Bagozzi, R. P. (1992). The self-regulation of attitudes, intentions, and behavior. *Social psychology quarterly*, 178-204.
- Balfour, D. L., & Wechsler, B. (1991). Commitment, performance, and productivity in public organizations. *Public Productivity & Management Review*, 355-367.
- Balfour, D L., Wechsler, B. (1990). Organizational Commitment: A Reconceptualization and Empirical Test Of Public-Private Differences, *Review of Public Personnel Administration*. 10(23):23-40.
- Becker, B., Gerhart, B.( 1996).The impact of human resource management on organizational performance: Progress and prospects. *Academy of Management Journal*, 39(1): 779–801.
- Boswell , W R., Boudreau, J W. (2000 ).Separating the Developmental and Evaluative Performance Appraisal Uses. *Journal of Business and Psychology*, 16(3): 391-412.
- Boswell, W. R., & Boudreau, J. W. (2002). Separating the developmental and evaluative performance appraisal uses. *Journal of Business and Psychology*, 16(3), 391-412.
- Cleveland, J. N., Murphy, K. R., & Williams, R. E. (1989). Multiple uses of performance appraisal: Prevalence and correlates. *Journal of applied psychology*, 74(1), 130.
- Cleveland, J.N. and Murphy, K.R. (1992), “Analyzing performance appraisal as goal-directed Behavior”, *Research in Personnel and Human Resources Management*, 1(10) pp. 121-85.
- DeCenzo, D. A., & Robbins, S. P. (1996). *Human resource management: 5<sup>th</sup>*, John Wiley & Sons.
- Delaney, J T., Huselid, M.(1996).The impact of human resource practices on perceptions of organizational performance. *Academy of Management Journal*, 39(4): 949–969.
- Dessler, G.(2007). *Human resource management*. Pearson Education , Business & Economics.
- Dipboye, R. L., & de Pontbriand, R. (1981). Correlates of employee reactions to performance appraisals and appraisal systems. *Journal of applied psychology*, 66(2), 248.
- Donaldson, S. I., & Grant-Vallone, E. J. (2002).Understanding self-report bias in organizational behavior research. *Journal of Business and Psychology*, 17(2), 245-260.
- Eisenberger, R., Huntington, R., Hutchison, S., & Sowa, D. (1986). Perceived organizational support. *Journal of Applied Journal of Applied Psychology*, 71.
- Eisenberger, R., Fasolo, P., & Davis-LaMastro, V. (1990). Perceived organizational support and employee diligence, commitment, and innovation. *Journal of applied psychology*, 75(1), 51.
- Fletcher, C. (2001). Performance appraisal and management: The developing research agenda. *Journal of Occupational and organizational Psychology*, 74(4), 473-487.
- Fletcher, C. (2002), “Appraisal: an individual psychological analysis”, in Sonnentag, S. (Ed.), *Psychological Management of Individual Performance*, Wiley, Chichester, pp. 115-35.
- Guest, D. E. (1997). Human resource management and performance: a review and research agenda. *International journal of human resource management*, 8(3), 263-276.
- Huselid, M. A. (1995).The impact of human resource management practices on turnover,productivity, and corporate financial performance. *Academy of ManagementJournal*, 38(3): 635-672.
- Jawahar, I., & Williams, C. R. (1997). Where all the children are above average: The performance appraisal purpose effect. *Personnel psychology*, 50(4), 905-925.
- Keeping, L. M., & Levy, P. E. (2000). Performance appraisal reactions: measurement, modeling, and method bias. *Journal of applied psychology*, 85(5), 708.
- Kehoe, R. R., & Wright, P. M. (2013). The impact of high-performance human resource practices on employees’ attitudes and behaviors. *Journal of Management*, 39(2), 366-391.



- Kuvaas, B. (2007). Different relationships between perceptions of developmental performance appraisal and work performance, *Personnel Review*, 36 (3): 378-397.
- Kuvaas, B. (2008) .An Exploration of How the Employee–Organization Relationship Affects the Linkage Between Perception of Developmental Human Resource Practices and Employee Outcomes.*Journal of Management Studies*, 45 (1):1-25.
- Lee, K ., Allen, N J.(2002).Organizational Citizenship Behavior and Workplace Deviance: The Role of Affect and Cognitions. *Journal of Applied Psychology*, 87(1): 131–142.
- Levy, P.E., Williams, J R. (2004) The Social Context of Performance Appraisal: A Review and Framework for the Future. *Journal of Management*, 30(6): 881–905.
- Mei, L.W. (2009). What makes a good citizen in service setting? *Service Industry Journal*, 29(5): 621–634.
- Meyer, J P., Paunonen S V., Gellatly, I. R., Goffin, R. D., & Jackson, D N. (1989). Organizational Commitment and Job Performance: It's the Nature of the Commitment That Counts. *Journal of Applied Psychology*, 74(1):152-156.
- Meyer, J. P.,Smith C. A. (2000). HRM Practices and Organizational Commitment: Test of a Mediation Model, *Canadian Journal of Administrative Sciences*, 17(4): 319-331.
- Millward L J (2005).Understanding Occupational & Organizational Psychology.Sage.
- Mount, M. K., Judge, T. A., Scullen, S. E., Sytsma, M. R., & Hezlett, S. A. (1998). trait, rater and level effects in 360degree performance ratings. *Personnel psychology*, 51(3), 557-576.
- Murphy, K.R. and Cleveland, J.N. (1995), Understanding Performance Appraisal: Social, Organizational, and Goal-based Perspectives, Thousand Oaks, CA, Sage.
- Paul, A., & Anantharaman, R. (2004). Influence of HRM practices on organizational commitment: A study among software professionals in India. *Human Resource Development Quarterly*, 15(1), 77-88.
- Pettijohn, C. E., Pettijohn, L. S., & d'Amico, M. (2001). Characteristics of performance appraisals and their impact on sales force satisfaction. *Human Resource Development Quarterly*, 12(2), 127-146.
- Podsakoff, P. M., & Organ, D. W. (1986). Self-reports in organizational research: Problems and prospects.*Journal of Management*, 12(4), 531-544.
- Preacher, K. J., & Hayes, A. F. (2004).SPSS and SAS procedures for estimating indirect effects in simple mediation models. *Behavior Research Methods, Instruments, & Computers*, 36(4), 717-731.
- Psychology*, 71, 500-507.
- Preacher, K. J., & Hayes, A. F. (2008). Asymptotic and resampling strategies for assessing and comparing indirect effects in multiple mediator models. *Behavior research methods*, 40(3), 879-891.
- Rhoades, L., Eisenberger, R., & Armeli, S. (2001). Affective commitment to the organization: the contribution of perceived organizational support. *Journal of applied psychology*, 86(5), 825.
- Riketta, M. (2002). Attitudinal organizational commitment and job performance: a meta-analysis, *Journal of Organizational Behavior*, 23(3): 257–266.
- Roberts, G E.,Reed, T. (1996). Performance Appraisal Participation, Goal Setting and Feedback : The Influence of Supervisory Style. *Review of Public Personnel Administration*, 16(29): 29-60.
- Rynes, S. L., Gerhart, B., & Parks, L. (2005). Personnel psychology: Performance evaluation and pay for performance. *Annu. Rev. Psychol.*, 56, 571-600.
- Sarmad ,Z., Bazargan, A., Hejazi , E.,(1997) research methods in behavioral science.4<sup>th</sup>. Agah publishing.(in Persian).
- Sherman, A., Bohlander, G, Snell, S.(2010). *Human Resource Management*.South western collage.IPT.
- Snape, E., & Redman, T. (2010). HRM Practices, Organizational Citizenship Behaviour, and Performance: A Multi-Level Analysis. *Journal of Management Studies*, 47(7), 1219-1247.
- Somers MJ , Birnbaum D.( 1998). Work-related commitment and job performance: it's also the nature of the performance that counts. *Journal of Organizational Behavior*. ( 19) 6.
- Spector, P E. (2002).Industrial and Organizational Psychology. John Wiley & Sons.
- Sun, L.-Y., Aryee, S., & Law, K. S. (2007). High-performance human resource practices, citizenship behavior, and organizational performance: A relational perspective. *Academy of Management Journal*, 50(3), 558-577.

- Torraco, R. J., Swanson, R. A. (1995). The strategic roles of human resource development.- *Human Resource Planning*, 18(4):10-21.
- Tremblay, M., Cloutier, J., Simard, G., Chênevert, D., & Vandenberghe, C. (2010). The role of HRM practices, procedural justice, organizational support and trust in organizational commitment and in-role and extra-role performance. *The international journal of human resource management*, 21(3), 405-433.
- Tziner, A., & Murphy, K. R. (1999). Additional evidence of attitudinal influences in performance appraisal. *Journal of Business and Psychology*, 13(3), 407-419.
- Tziner, A., Joanis, C., & Murphy, K. R. (2000). A comparison of three methods of performance appraisal with regard to goal properties, goal perception, and ratee satisfaction. *Group & Organization Management*, 25(2), 175-190.
- Wayne, S. J., Shore, L. M., & Liden, R. C. (1997). Perceived organizational support and leader-member exchange: A social exchange perspective. *Academy of Management Journal*, 40(1), 82-111.
- Williams, L.J, Anderson, S.E. (1991). Job satisfaction and organizational commitment as predictors of organizational citizenship and in-role behaviors. *Journal of Management*, 17(3): 601-617.
- Wright, P. M., Gardner, T. M., Moynihan, L. M., & Allen, M. R. (2005). The relationship between HR practices and firm performance: Examining causal order. *Personnel psychology*, 58(2), 409-446.
- Yang, Y.-C. (2012). High-involvement human resource practices, affective commitment, and organizational citizenship behaviors. *The Service Industries Journal*, 32(8), 1209-1227.
- Youngcourt, S. S., Leiva, P. I., & Jones, R. G. (2007). Perceived purposes of performance appraisal: Correlates of individual-and position-focused purposes on attitudinal outcomes. *Human Resource Development Quarterly*, 18(3), 315-343.

The IISTE is a pioneer in the Open-Access hosting service and academic event management. The aim of the firm is Accelerating Global Knowledge Sharing.

More information about the firm can be found on the homepage:  
<http://www.iiste.org>

## CALL FOR JOURNAL PAPERS

There are more than 30 peer-reviewed academic journals hosted under the hosting platform.

**Prospective authors of journals can find the submission instruction on the following page:** <http://www.iiste.org/journals/> All the journals articles are available online to the readers all over the world without financial, legal, or technical barriers other than those inseparable from gaining access to the internet itself. Paper version of the journals is also available upon request of readers and authors.

## MORE RESOURCES

Book publication information: <http://www.iiste.org/book/>

Recent conferences: <http://www.iiste.org/conference/>

## IISTE Knowledge Sharing Partners

EBSCO, Index Copernicus, Ulrich's Periodicals Directory, JournalTOCS, PKP Open Archives Harvester, Bielefeld Academic Search Engine, Elektronische Zeitschriftenbibliothek EZB, Open J-Gate, OCLC WorldCat, Universe Digital Library, NewJour, Google Scholar

