

Measurement of Teacher Sense of Efficacy: A Study with Myanmar In-service Teachers

Ling Kee Htang*

Institute of Educational Science, Zhejiang Normal University, Jinhau City, China; 688 Yingbin Avenue, Jinhua City, Zhejiang Province 321004, China

Abstract

For the purpose of measuring in-service teachers' self-efficacy, the Teacher Sense of Efficacy Scale (TSES) short form, developed by Tschannen-Moran and Woolfork Hoy (2001), was revised and validated. The sample consisted of 101 in-service teachers from three different levels: public high school, education college and university. Data were analyzed by using SPSS to compute reliability and other psychometric properties, as well as AMOS to validate the measurement model. The results indicated that the TSES short form is reliable and valid to assess self-efficacy of Myanmar In-service teachers. All the subscales had satisfactory reliability. In addition, ANOVA results indicated that there were significant differences in efficacy for classroom management between high school teacher and university teacher. In terms of qualification, professional degree holders (i.e. B.Ed. and M.Ed.) were more efficacious than academic degree holders (i.e. M.A. or M.Sc.).

Keywords: scale; self-efficacy; in-service teacher; Myanmar

1. Introduction

There is no doubt that teacher efficacy is a very important factor in improving education around the world. Since Bandura (1977) published his influential work, "Self-efficacy: Toward a unifying theory of behavioral change", the remarkable growth of teacher self-efficacy research has attracted attention. Tschannen-Moran & Hoy, (2001) defined teacher efficacy as the judgment of the teacher's capabilities to bring about desired outcomes of student engagement and learning. Many studies showed that teacher efficacy has correlation with various practical concerns such as self-regulated learning, motivation and academic performance work stress, job satisfaction, student outcomes (Lau, Liem, & Nie, 2008; Usher & Pajares, 2008; Chong, Klassen, Huan, Wong, & Kates, 2010; Moe, Pazzaglia, & Ronconi, 2010).

Teacher efficacy can still influence the level of aspiration of teachers, their innovation and persistence even when encountering difficulties. Efficacious teachers are more likely to stay in their teaching professions, spend more time teaching, make greater efforts in classroom management, and show greater enthusiasm for teaching. Moreover, teacher with high level of efficacy are more responsive to meet the needs of students. They are not much critical of students' mistakes, they are willing to spend more time working with students who have problems, and they are more involved in their learning experiences (Ho & Hau, 2004; Tschannen-Moran & Hoy, 2001).

Many researchers have paid much attention to measuring teacher efficacy and identifying factors that increase teacher efficacy, primarily because it has a great impact on behavior of students and teachers. They have developed instruments to measure it over time. However, most of these instruments were developed based on the appropriateness of Western context. There is lack of published research studies on teacher efficacy in Myanmar. This study aims to validate Teacher Sense of Efficacy Scale (TSES) short form, developed by Tschannen-Moran and Woolfork Hoy (2001) for measuring in-service teachers in the context of Myanmar.

1.1 Measurement of teacher self-efficacy

Evaluating teacher efficacy can be drawn back to the RAND organization study in the 1970s. Based on social learning theory (Rotter, 1966), the RAND model decomposed teacher efficacy into general and personal teacher efficacy. In the 1980s, rounded on RAND's items and Bandura's theories of self-efficacy and outcome efficacy, Gibson and Dembo (1984) developed a 30-item measurement for teacher efficacy. Finally, Gibson and Dembo (1984) concluded that teacher efficacy comprised two factors called personal teaching efficacy and general teaching efficacy as the 30 items were extracted into two factors in their findings.

Emmer and Hickman (1991) adapted Gibson and Dembo's scale into a 36-item measurement to evaluate teacher efficacy and found that three different dimensions; namely personal teaching efficacy, efficacy for classroom management or discipline and external influences.

According to Bandura (1997), teacher efficacy depends not only on teachers' beliefs in their ability to teach subject matter but also on their beliefs in managing classroom discipline so that it can create a good learning environment. Likewise, using teaching resources, and giving guidance and support the parents to help their children learn well in school are other factors on which teacher efficacy depends. Therefore, Bandura developed a 30-item teacher self-efficacy scale with seven subscales, namely efficacy to influence decision making, efficacy to influence school resources, instructional efficacy, disciplinary efficacy, efficacy to enlist parental

involvement, efficacy to enlist community involvement and efficacy to create a positive school climate (Bandura, 1997).

Although many researches have been done on the study of teacher efficacy, its conceptual framework and measurement are still being debated, revised and tested. In response to the aforementioned limitations, Tschannen-Moran and Hoy (2001) developed a Teacher Effective Energy Scale (TSES) that corresponds to the tasks teachers face at school. There were three factors in this scale, namely efficacy for instructional strategy, efficacy for classroom management, and efficacy for student engagement. TSES is a promising development in measuring teacher efficacy. There are two forms, the long form of 24 items and the short form of 12 items. Both short and long forms have three dimensions with good internal consistent reliability for measuring in-service teachers' self-efficacy. The TSES has been validated for its use with both pre-service and in-service teachers from a number of countries (e.g. United States Tschannen-Moran & Woolfolk Hoy, 2001; Fives & Buehl, 2009), Europe (Klassen et al., 2009), Singapore (Klassen et al., 2009; Nie, Lau, & Liau, 2012), China, Korea, and Japan (Ruan et al., 2015).

1.2 Who are teachers in high schools and universities in Myanmar?

In Myanmar, the current basic education system includes five years of primary education (kindergarten to fourth grade), four years of junior high school and two years of high school education. At present, there are 47,363 basic education schools in Myanmar, reaching approximately 9.26 million students. Most of these schools are managed by the Department of Basic Education under the Ministry of Education. In addition, most students receive their basic education through monasteries, private, community, and other types of schools. According to NESP (2017), there were 47,363 schools, 340,955 teachers and 9,257,970 in the basic education sectors in 2015-2016 school year.

Pre-service teachers and in-service teachers for public high schools are trained through three institutions in Myanmar. Pre-service teachers have to take five-year B.Ed. course offered by two universities of education (UoEs) under the Ministry of Education. This course has two different entry requirements. The first system, the direct intake allows students who passed the high school matriculation exam with high marks. In this case, the Department of Higher Education considers all the applicants for selection. The second admission system is for those who have completed two-year pre-service training at education college with the requisite qualification to join B.Ed. course in UoEs.

The University of Development of National Races (UDNR) also provides B.Ed. course specifically to ethnic minorities. In spite of providing the similar courses as UoEs, this university is under the Ministry of Border Affairs and it currently trains only pre-service teachers.

On the contrary, in-service teachers have to take entrance examination for B.Ed. course. All the candidates have to meet the requirements such as years of teaching experiences, academic qualification and a position of middle school teacher. The selected in-service teachers have to take two-year B.Ed. course at UoEs. All the B.Ed. degree holders become senior teachers in high school for basic education sector.

Generally, any master degree holders who pass entrance examination are eligible to be tutors or demonstrators in a university. Myanmar has 171 higher education institutions including colleges, degree colleges and universities which are supervised by eight ministries. In the 2015 academic year, the Ministry of Education was responsible for 225,178 full-time students pursuing higher education and 411,164 students received higher education through distance education universities (NESP, 2017).

2. Research questions

1. What are the factor structures of the short form of TSES for in-service teachers in Myanmar context?
2. Is there any significant difference in in-service teachers' self-efficacy by their levels?
3. Is there any significant difference in in-service teachers' self-efficacy by their qualifications?

3. Method

3.1 Participants

Since this research involves in-service teachers from public high schools, education colleges and universities as respondents, their names, the name of schools, colleges and universities were kept anonymously for ethical considerations. All the participants were made aware of the purpose of research, that their participation in the study was voluntary, and that all the information would be treated with confidentiality.

There were 101 respondents divided into three groups in the study: 36 senior teachers from high schools, 34 teacher educators from education colleges and 31 university tutors, demonstrators, assistant lecturers and lectures. All senior teachers were B.Ed. degree holders and they were working in public secondary schools. The teacher educators were a mix of academic and professional degree holders as there were educational departments (i.e. Educational Theory, Educational Psychology and Methodology Departments) and academic departments (i.e. Department of English, Mathematics, and so on) in Education College. The third groups of participants in this

study comprised tutors, demonstrators, assistant lecturers from Arts and Science University. Twenty-six participants (25.7%) were males and 75 (74.3%) were females. Most participants 73(72%) are in the age between 25 and 34. Fourteen (13.9%) participants were under the age of 14 and 14 (13.9%) were above 34. Regarding their position, 36 (33.7%) were senior teachers, 25 (24.8%) were tutors or demonstrators, 38 (37.6%) were assistant lecturers and two (2%) were lecturers. Thirty-one (30.7%) participants were M.A. /M.Sc. degree holders, 30 (29.7%) were B.Ed. degree holders, 35 (34.7%) were M.Ed. degree holders and five (5%) were Ph.D. degree holders. Concerning teaching experiences, 34 (33.7%) respondents were under five years of teaching services, 49 (48.5%) were 5-9 years and 18 (17.8%) were above 10 years (see Table 1).

Table 1
Demographic Information of In-service teachers

		Level			Total
		High school teacher	Teacher educator	University teacher	
Gender	Male	14	5	7	26 (25.7%)
	Female	22	29	24	75 (74.3%)
	Total	36	34	31	101
Age	Under 25	14	0	0	14 (13.9%)
	25-34	20	26	27	73 (72.2%)
	35 and above	2	8	4	14 (13.9%)
	Total	36	34	31	101
Teaching Position	ST	36	0	0	36 (35.6%)
	T/D	0	12	13	25 (24.8%)
	AL	0	21	17	38 (37.6%)
	L and above	0	1	1	2 (2%)
Total	36	34	31	101	
Teaching Experience	Under 5	18	5	11	34 (33.7%)
	5-9	14	19	16	49 (48.5%)
	10 and above	4	10	4	18 (17.8%)
	Total	36	34	31	101
Academic Qualification	M.A./M.Sc.	0	4	27	31 (30.7%)
	B.Ed.	24	6	0	30 (29.7%)
	M.Ed.	12	23	0	35 (34.7%)
	Ph.D.	0	1	4	5 (4.9%)
	Total	36	34	31	101

ST = senior teacher in high school; T/D = tutor or demonstrator; AL = assistant lecturer; L = Lecturer

3.2 Instrumentation

This study is a part of validating “Teachers’ Sense of Efficacy Scale” (TSES) developed by Tschannen-Moran and Woolfolk Hoy (2001) to measure teachers’ sense of efficacy for teaching that is currently being used by many educational researchers.

The instrument has two versions: long form (24 items) and short form (12 items). The short form was used in this study due to the limitation of sample size. However, both forms have been considered almost identical in terms of their effectiveness in measuring teacher self-efficacy because they have very similar psychometric values (Tschannen-Moran & Woolfolk Hoy, 2001). The short version of TSES is composed of 12 items with three subscales: “efficacy for instructional strategies” (4 items), “efficacy for classroom management” (4 items) and “efficacy of student engagement” (4 items). The overall reliability of the original instrument ($\alpha = .90$), was high, while the examination of the construct validity of TSES, by assessing its correlation with other existing scales of teaching efficacy, showed that the new measurement successfully confirmed the construct of efficacy (Tschannen-Moran & Hoy, 2001). The items were translated into Myanmar Language and piloted with five teachers (two from university, one from education colleges and two from high schools) who were excluded from the main study. Based on the pilot findings and the participants’ feedbacks, the original item, “how well can you establish a classroom management system with each group of students?” was adapted as “how well can you establish a classroom management system with each class?”. This item is about teachers’ classroom management to work with each group of students. In the context of Myanmar, grouping students for differentiated instruction does not work well due to big class size and it is not a common practice although it is recommended to use. Another item, “how much can you assist families in helping their children do well in school?” was adapted as “how much can you give guidance and instructions to families in helping their children do well in school?” in accord with Myanmar context. As in-service teachers felt more comfortable with the revised version of the instrument, the original instruments which has a 9-point continuum with anchors from 1 =

Nothing to 9 = A Great Deal were reduced to 5 for the purposes of this particular study. The 9-point scale in the original version of TSES became a 5-point scale from 1 (not at all) to 5 (a great deal).

3.3 Data collection and procedure

The data for this study was collected between May 2018 and June 2018 via online survey questionnaires. The teacher educators' email addresses were accessed with the assistance of two lecturers from Yankin Education Colleges, Yangon, Myanmar and high school teachers' and university teachers' email address were reached through some Myanmar Ph.D. scholars from Zhejiang Normal University and Shanghai University, China. The questionnaires contained three parts: (1) cover letter that explains the purpose of the research, their participation was voluntary and all the information would be treated with utmost confidentiality (2) demographic questionnaires, and (3) 12 items questionnaires to explore their self-efficacy. In the beginning of May 2018, the survey link was sent to their mailbox with detailed instructions and explanations how to do. Among the purposefully selected target sample, 101 participants completed the questionnaires voluntarily. According to Johnson & Christensen (2017), internet questionnaires are the most common of all survey methods used today as everyone across the world that has access to the internet can be included in the survey. A comparative study of the psychometric properties of the paper-based and computer survey data by Ravert, Gomez-Scott and Donnellan (2015) showed that there were no evident differences between these two methods regarding internal consistencies (Ravert, Gomez-Scott & Donnellan, 2015).

3.4 Data analysis

The collected data were analysed by SPSS Statistical software (version 23) and AMOS Analysis of moment structures (version 23). The exploratory factor analytic procedure was conducted in order to re-examine the factor structure of the short form of the original TSES whether it can be culturally appropriate for in-service teachers in Myanmar. Cross-validity was evaluated by confirmatory factor analysis by using AMOS. Internal consistency reliability coefficients (Cronbach's alphas) was also analysed for each dimension of TSES. Moreover, the mean scores were calculated and One-way ANOVA was conducted to test where the differences of the means laid.

4. Results

4.1 Exploratory factor analysis

Since the original English version of TSES was translated and adapted in accord with Myanmar context, exploratory factor analysis with maximum likelihood estimation was conducted to retest the factor structure. The results of the KMO measure of sampling adequacy, 0.851 and Bartlett's test of sphericity (BTS value = 566.03, $p < 0.001$) showed that it was appropriate to perform a factor analysis (Tabachnick & Fidell, 2007). An oblique rotation (direct oblimin) was chosen to interpret the factor as the previous studies showed that the dimensions are correlated (Tschannen-Moran & Woolfolk Hoy, 2001). The results of analysing the 12 items revealed that three factors emerging with eigenvalues greater than 1. The extracted three factors indicated that TSES can be also used to examine teachers' self-efficacy in Myanmar context. All the items loaded on each of the original three dimensions respectively. The overall percentage of variance extracted was 56.35%. All items had pattern coefficients were higher than 0.45, which was suggested to be satisfactory by Pituch and Stevens (2015). In addition, Table 2 described the means, standard deviations, and inter-factor correlations.

Table 2

Factor Means and Inter-factor Correlations of TSES

	M	SD	EIS	ECM	ESE
EIS	3.56	0.65	-		
ECM	3.83	0.71	.416*	-	
ESE	3.23	0.7	.548*	.564*	-

** $p < .01$; EIS = Efficacy for Instructional Strategy; ECM = Efficacy for Classroom Management; ESE = Efficacy for Student Engagement

4.2 Reliability analysis of TSES short forms with in-service teacher

Internal consistency reliability analysis yield Cronbach alpha coefficients of 0.88 for the overall TSES, 0.78 for EIS, 0.86 for ECM, and 0.83 for ESE, which indicated that the scale had satisfactory reliability.

4.3 Confirmatory factor analysis (CFA)

In order to confirm the factor structure of the original short form of TSES, confirmatory analysis was employed using the analysis of moment structures (AMOS) version 23 statistical software package. Maximum Likelihood estimation was used. The model specification and the parameter estimates were shown in Figure 1. The fit indices for the three-factor model for the short-form (12 items) TSES were acceptable as the results from CFA

revealed that $\chi^2(51) = 69.206$, $p = .064$, $\chi^2/df = 1.357$, $CFI = .966$, $NFI = .884$, $RMSEA = .06$, $IFI = .967$, $GFI = .898$, $SRMR = .0538$.

According to Hu & Bentler (1999), a good model fit shown by a χ^2/df value lower than 2 or RMSEA value lower than 0.05, while RMSEA values between 0.05 and 0.08 are considered reasonable fit. They also suggested CFI value greater than .95 is good model fit, SRMR value less than .08 is good model fit and NFI value .87 as acceptable model fit.

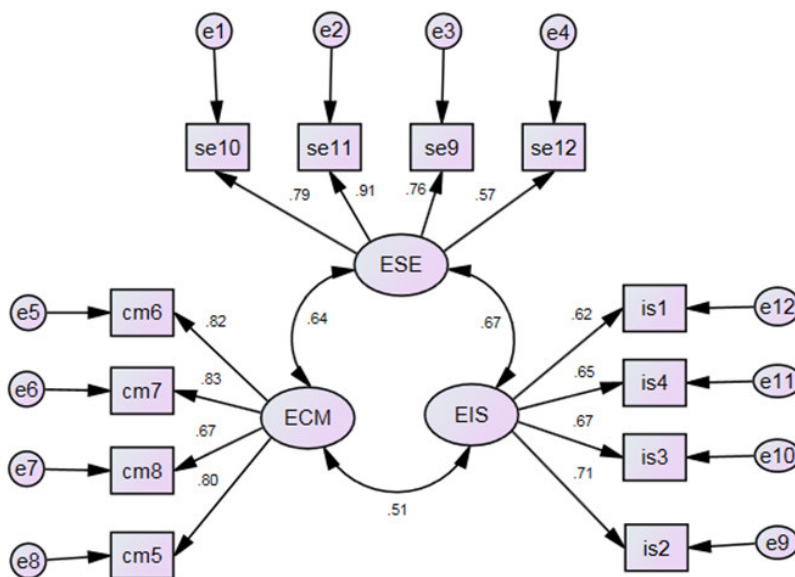

Figure 1. Standardized coefficients for the three-factor model of TSES short form

4.4 In-service teachers' self-efficacy by their level

Table 3 shows that the three groups of high school teachers, teacher educators and university teachers demonstrated different levels of efficacy in overall and each dimension. Generally, high school teachers seemed to be the most confident among the groups ($M = 3.6$) in terms of their own ability to affect students. However, high school teachers were appeared to be the least confident with their capability in terms of instructional strategy among the three groups ($M = 3.46$). Concerning efficacy for instructional strategy, teacher educators from education colleges possessed the highest mean scores ($M = 3.63$), indicating that they believed in their ability to teach their students very well. With respect to efficacy for classroom management, high school teachers appeared to show the greatest confidence among the three groups again ($M = 4.1$). However, in terms of efficacy for student engagement, teacher educators seemed to be the most confident in their ability ($M = 3.3$), indicating that they believed they could motivate their students to engage in teaching-learning activities. Interestingly, university teachers seemed to show the lowest efficacy among the groups in all dimensions.

Table 3
Description of In-service Teachers' Self-efficacy by their Level

		N	Mean	SD	Minimum	Maximum
Total	High School Teacher	36	3.60	.53651	2.00	4.83
	Teacher Educators	34	3.58	.49279	2.08	4.75
	University Teacher	31	3.41	.65845	2.50	5.00
	Total	101	3.54	.56391	2.00	5.00
EIS	High School Teacher	36	3.46	.73070	2.25	5.00
	Teacher Educators	34	3.63	.48553	2.25	4.50
	University Teacher	31	3.59	.71749	2.25	5.00
	Total	101	3.56	.65181	2.25	5.00
ECM	High School Teacher	36	4.10	.66622	2.00	5.00
	Teacher Educators	34	3.82	.55497	2.00	4.75
	University Teacher	31	3.52	.79413	2.25	5.00
	Total	101	3.83	.70776	2.00	5.00
ESE	High School Teacher	36	3.26	.68527	1.75	4.50
	Teacher Educators	34	3.30	.61478	2.00	5.00
	University Teacher	31	3.13	.81105	1.75	5.00
	Total	101	3.23	.70112	1.75	5.00

EIS = Efficacy for Instructional Strategy; ECM = Efficacy for Classroom Management;
 ESE = Efficacy for Student Engagement

One-way ANOVA was conducted to test the differences of teachers' self-efficacy by the groups. The results show that there were no significant differences in teacher self-efficacy among and between the three groups for overall [$F(2, 98) = 1.110, p = .334$], efficacy for instructional strategy [$F(2, 98) = .672, p = .513$], and efficacy for student engagement [$F(2, 98) = .519, p = .597$] (see Table 5). However, significant differences were found in efficacy for classroom management [$F(2, 98) = 6.013, p = .003$].

Table 5
ANOVA results for In-service Teachers' Self-efficacy in terms of their Level of teaching

		Sum of Squares	df	Mean Square	F	p
Total	Between Groups	.704	2	.352	1.110	.334
	Within Groups	31.095	98	.317		
	Total	31.800	100			
EIS	Between Groups	.575	2	.287	.672	.513
	Within Groups	41.910	98	.428		
	Total	42.485	100			
ECM	Between Groups	5.475	2	2.738	6.013	.003
	Within Groups	44.618	98	.455		
	Total	50.093	100			
ESE	Between Groups	.515	2	.258	.519	.597
	Within Groups	48.642	98	.496		
	Total	49.157	100			

EIS = Efficacy for Instructional Strategy; ECM = Efficacy for Classroom Management;
 ESE = Efficacy for Student Engagement

Tukey HSD Test was conducted to find out where the differences laid. The findings indicate that there were significant differences in efficacy for classroom management between high school teacher and university teacher ($p = .002$) (see Table 6).

Table 6
Tukey HSD results for In-service Teachers' Self-efficacy for Classroom Management by their Level

I (group)	J (group)	Mean Difference (I-J)	p
High School Teacher	Teacher Educators	.28105	.195
	University Teacher	.57303*	.002
Teacher Educators	High School Teacher	-.28105	.195
	University Teacher	.29198	.195
University Teacher	High School Teacher	-.57303*	.002
	Teacher Educators	-.29198	.195

*. The mean difference is significant at the 0.05 level.

4.5 In-service teachers' self-efficacy by their academic and professional qualification

All the participants were divided into three groups in terms of their academic and professional qualifications. Table 4 shows that the three groups of teachers demonstrated different levels of efficacy in overall and each dimension in terms of their qualification. Remarkably, professional degree holders (i.e. B.Ed. and M.Ed. degree holders) seemed to possess higher self-efficacy in the overall and each dimension. MEd degree holders appeared to show the highest confidence in their own ability concerning efficacy for instructional strategy ($M = 3.62$) and efficacy for classroom management ($M = 3.99$), as well as overall efficacy. On the other hand, B.Ed. degree holders seemed to be the most confident in their ability in terms of student engagement ($M = 3.38$).

Table 4

Description of In-service Teachers' Self-efficacy by their Qualification

		N	Mean	SD	Minimum	Maximum
Total	M.A./M.Sc./ Ph.D.	36	3.39	.61780	2.50	5.00
	B.Ed.	30	3.62	.55867	2.00	4.83
	M.Ed.	35	3.63	.49024	2.08	4.75
	Total	101	3.54	.56391	2.00	5.00
EIS	M.A./M.Sc./ Ph.D.	36	3.53	.68179	2.25	5.00
	B.Ed.	30	3.51	.72956	2.25	5.00
	M.Ed.	35	3.62	.55695	2.25	4.50
	Total	101	3.56	.65181	2.25	5.00
ECM	M.A./M.Sc./ Ph.D.	36	3.54	.75000	2.25	5.00
	B.Ed.	30	3.98	.69279	2.00	5.00
	M.Ed.	35	3.99	.59250	2.00	4.75
	Total	101	3.83	.70776	2.00	5.00
ESE	M.A./M.Sc./ Ph.D.	36	3.10	.76830	1.75	5.00
	B.Ed.	30	3.38	.60796	1.75	4.50
	M.Ed.	35	3.25	.69663	1.75	5.00
	Total	101	3.23	.70112	1.75	5.00

EIS = Efficacy for Instructional Strategy; ECM = Efficacy for Classroom Management;

ESE = Efficacy for Student Engagement

According to the results of ANOVA, there were no significant differences in teacher self-efficacy among and between the three groups for overall [$F(2, 98) = 1.952, p = .714$], efficacy for instructional strategy [$F(2, 98) = .272, p = .763$], and efficacy for student engagement [$F(2, 98) = 1.309, p = .275$] (see Table 7). Nevertheless, significant differences were found in efficacy for classroom management [$F(2, 98) = 4.896, p = .009$] (see Table 7).

Table 7

ANOVA results for In-service Teachers' Self-efficacy for Classroom Management by their Qualification

		Sum of Squares	df	Mean Square	F	p
Total	Between Groups	1.218	2	.609	1.952	.147
	Within Groups	30.581	98	.312		
	Total	31.800	100			
EIS	Between Groups	.234	2	.117	.272	.763
	Within Groups	42.251	98	.431		
	Total	42.485	100			
ECM	Between Groups	4.551	2	2.275	4.896	.009
	Within Groups	45.542	98	.465		
	Total	50.093	100			
ESE	Between Groups	1.279	2	.639	1.309	.275
	Within Groups	47.878	98	.489		
	Total	49.157	100			

EIS = Efficacy for Instructional Strategy; ECM = Efficacy for Classroom Management;

ESE = Efficacy for Student Engagement

According to Table 8, Tukey HSD Test results indicated that there were significant differences in efficacy for classroom management between B.Ed. degree holders ($M = 3.98, SD = .69279$) and academic degree holders ($M = 3.54, SD = .75000$) at 0.05 level. Significant differences in efficacy for classroom management were also found between M.Ed. degree holders ($M = 3.99, SD = .59250$) and academic degree holders ($M = 3.54, SD = .75000$) at 0.05 level. Based on the findings, it can be concluded that professional degree holders were more efficacious than academic degree holders concerning classroom management.

Table 8
Tukey HSD results for In-service Teachers' Self-efficacy for Classroom Management by their Qualification

(I) Qualification	(J) Qualification	Mean Difference (I-J)	<i>p</i>
M.A./M.Sc./Ph.D.	B.Ed.	-.43333*	.031
	M.Ed.	-.45119*	.017
B.Ed.	M.A./M.Sc./Ph.D.	.43333*	.031
	M.Ed.	-.01786	.994
M.Ed.	M.A./M.Sc./Ph.D.	.45119*	.017
	B.Ed.	.01786	.994

*The mean difference is significant at the 0.05 level.

5. Discussion and conclusion

The main aim of this study is to revise and validate the Teacher Sense of Efficacy Scale short form by developed by Tschannen-Moran and Woolfork Hoy (2001) that can be used to assess self-efficacy of Myanmar In-service teachers. Out of 12 items in the original English version, two items were revised based on the pilot findings. The original item, "how well can you establish a classroom management system with each group of students?" was adapted as "how well can you establish a classroom management system with each class?". In the context of Myanmar, grouping students for differentiated instruction does not work well due to big class size and it is not a common practice although it is recommended to use. The result is also similar in the study of Ruan et al. (2015) that indicated the school context in all three Asian countries i.e. China, Japan and Korea where classroom instruction still follows the "one-size-fits-all" model and grouping students for differentiated instruction is not a common practice. Consequently, they excluded the item in the final proposed instrument because it did not fit well. However, this item was adapted based on the pilot study rather than excluding in this study. Another item, "how much can you assist families in helping their children do well in school?" was also adapted as "how much can you give guidance and instructions to families in helping their children do well in school?" in accord with Myanmar context.

The results of exploratory factor analysis showed that all the items loaded on each of the original three dimensions respectively and the overall percentage of variance extracted was 56.35%. All items had pattern coefficients were higher than 3.45, which was suggested to be satisfactory by Pituch and Stevens (2015). Again, internal consistency reliability analysis yield Cronbach alpha coefficients of 0.88 for the overall TSES, 0.78 for EIS, 0.86 for ECM, and 0.83 for ESE, which indicated that the scale had satisfactory reliability. Furthermore, the results from CFA revealed that $\chi^2(51) = 69.206$, $p = .064$, $\chi^2/df = 1.357$, CFI = .966, NFI = .884, RMSEA = .06, IFI = .967, GFI = .898, SRMR = .0538, which indicated the fit indices for the three-factor model for the short-form (12 items) TSES were acceptable.

Further investigations were made to explore Myanmar in-service teachers' self-efficacy with the validated scale. One-way ANOVA was conducted to test efficacy of the teachers in terms of their level of teaching and their qualification. Generally, high school teachers seemed to be the most confident among the groups in terms of their own ability to affect students. However, they appeared to be the least confident with their capability in terms of instructional strategy among the three groups. A possible explanation for this might be that there was lack of continuing professional development for them (Ulla, 2018) and they merely just relied on what they had learned from teaching institutions. Consequently, there became little chance to find an innovative instructional strategy. Concerning efficacy for instructional strategy and efficacy for student engagement, teacher educators from education colleges possessed the highest mean scores indicating that they believed in their ability to teach their students very well and motivate their students to engage in teaching-learning activities. It is vividly seen that teacher education had more opportunities for their professional development such as Efect project by British Council (Ulla, 2017). Although one-way ANOVA results showed there were no significant differences in teacher self-efficacy among and between the three groups for overall efficacy, high school teachers were more efficacious than university teachers regarding classroom management. Another possible explanation may be that secondary students are more obedient than university students in Myanmar context. It is likely that high school teachers may be able to handle the disruptive students more effectively than university teachers.

In terms of their qualification, professional degree holders (i.e. B.Ed. and M.Ed. degree holders) seemed to possess higher self-efficacy in the overall and each dimension. MEd degree holders appeared to show the highest confidence in their own ability concerning efficacy for instructional strategy and efficacy for classroom management, as well as overall efficacy. On the other hand, B.Ed. degree holders seemed to be the most confident in their ability in terms of student engagement. Tukey HSD Test results indicated professional degree holders were more efficacious than academic degree holders concerning classroom management. A possible reason for this finding may stem from the fact that professional qualifications are important variables in the teaching profession as teachers participate in professional training, seminars and further professional education

to be more capable and knowledgeable in dealing with classroom discipline (Shah, 2006).

6. Limitations and future directions

Three major limitations should be noted although the instrument proposed in this study is reliable and valid. First, this study only supported the use of the short form in the context of Myanmar in-service teachers. Future research may also consider examining whether the 24-item long form and the 12-item short form TSES are comparable in their psychometric properties appropriate for teachers in Myanmar.

Second, the instrument was validated using sample data from high school teachers, teacher educators and university teachers. The three groups of teacher have different school cultures and teaching environments as the nature of secondary school, teacher training institution and university are different in Myanmar. Since teacher efficiency is specific context, its source may vary from population to population as well. Further work should consider the differences in school culture and teaching environments by referring participants from the population of interest.

Last, the researcher used only self-reported responses of questionnaires to examine teachers' self-efficacy of Myanmar in-service teachers. A mixed method should be conducted as further investigations to gain a better understanding of efficacy beliefs of Myanmar in-service teachers.

References

- Bandura, A. (1977). Self-efficacy: toward a unifying theory of behavioral change. *Psychological review*, 84(2), 191.
- Bandura, A. (1997). *Self-efficacy: The exercise of control*. New York, NY: W.H. Freeman.
- Chong, W. H., Klassen, R. M., Huan, V. S., Wong, I., & Kates, A. D. (2010). The relationships among school types, teacher efficacy beliefs, and academic climate: Perspective from Asian middle school *Journal of Educational Research*, 103(3), 183-190. doi: 10.1080/00220670903382954
- Emmer, E., & Hickman, J. (1991). Teacher efficacy in classroom management and discipline. *Educational and Psychological Measurement*, 51, 755-765. doi:10.1177/0013164491513027
- Fives, H., & Buehl, M. M. (2009). Examining the factor structure of the teachers' sense of efficacy scale. *Journal of Experimental Education*. <https://doi.org/10.1080/00220970903224461>
- Gibson, S., & Dembo, M. (1984). Teacher efficacy: A construct validation. *Journal of Educational Psychology*, 76, 569-582.
- Ho, I. T., & Hau, K. T. (2004). Australian and Chinese teacher efficacy: Similarities and differences in personal instruction, discipline, guidance efficacy and beliefs in external determinants. *Teaching and Teacher Education*, 20, 313-323.
- Hu, L. T., & Bentler, P. M. (1999). Cutoff criteria for fit indexes in covariance structure analysis: Conventional criteria versus new alternatives. *Structural equation modeling: a multidisciplinary journal*, 6(1), 1-55.
- Johnson, B., & Christensen, L. B. (2017). *Educational research: Quantitative, qualitative, and mixed approaches*. Thousand Oaks, Calif: SAGE Publications.
- Klassen, R. M., Bong, M., Usher, E. L., Chong, W. H., Huan, V. S., Wong, I. Y. F., & Georgiou, T. (2009). Exploring the validity of a teachers' self-efficacy scale in five countries. *Contemporary Educational Psychology*, 34(1), 67-76. <https://doi.org/10.1016/j.cedpsych.2008.08.001>
- Lau, S., Liem, A. D., & Nie, Y. (2008). Task - and self - related pathways to deep learning: The mediating role of achievement goals, classroom attentiveness, and group participation. *British Journal of Educational Psychology*, 78(4), 639-662. doi: 10.1348/000709907x270261
- Liem, A. D., Lau, S., & Nie, Y. (2008). The role of self-efficacy, task value, and achievement goals in predicting learning strategies, task disengagement, peer relationship, and achievement outcome. *Contemporary Educational Psychology*, 33(4), 486-512. doi: 10.1016/j.cedpsych.2007.08.001
- Moe, A., Pazzaglia, F., & Ronconi, L. (2010). When being able is not enough. The combined value of positive affect and self-efficacy for job satisfaction in teaching. *Teaching and Teacher Education*, 26(5), 1145-1153. doi: 10.1016/j.tate.2010.02.010
- NESP (2017). *National Education Strategic Plan 2016-21*. Ministry of Education, Myanmar
- Nie, Y., Lau, S., & Liau, A. K. (2012). The Teacher Efficacy Scale: A Reliability and Validity Study. *The Asia-Pacific Education Researcher*, 212, 414-421.
- Pituch, K. A., & Stevens, J. P. (2015). *Applied multivariate statistics for the social sciences: Analyses with SAS and IBM's SPSS*. Routledge.
- Ravert, R. D., Gomez-Scott, J., & Donnellan, M. B. (2015). Equivalency of paper versus tablet computer survey data. *Educational Researcher*, 44(5), 308. doi: 10.3102/0013189X15592845
- Rotter, J. B. (1966). Generalized expectancies for internal versus external control of reinforcement. *Psychological Monographs*, 80, 1-28. doi: 10.1037/h0092976
- Ruan, J., Nie, Y., Hong, J., Monobe, G., Zheng, G., Kambara, H., & You, S. (2015). Cross-Cultural Validation

- of Teachers' Sense of Efficacy Scale in Three Asian Countries: Test of Measurement Invariance. *Journal of Psychoeducational Assessment*, 33(8), 769–779. <https://doi.org/10.1177/0734282915574021>
- Shah, S. (2006). Educational leadership: An Islamic perspective. *British Educational Research Journal*, 32(3), 363-385.
- Tabachnick, B. G., & Fidell, L. S. (2007). *Using multivariate statistics*. Allyn & Bacon/Pearson Education.
- Tschannen-Moran, M., & Hoy, A. W. (2001). Teacher efficacy: Capturing an elusive construct. *Teaching and teacher education*, 17(7), 783-805.
- Ulla, M. B. (2017). Teacher Training in Myanmar: Teachers' Perceptions and Implications. *International Journal of Instruction*, 10(2), 103-118
- Ulla, M. B. (2018). In-Service Teachers' Training: The Case of University Teachers in Yangon, Myanmar. *Australian Journal of Teacher Education*, 43(1), 66-77.
- Usher, E. L., & Pajares, F. (2008). Sources of self-efficacy in school: Critical review of the literature and future directions. *Review of Educational Research*, 78(4), 751- 796. doi: 10.3102/0034654308321456