

Potential Corrosion Issue in CO₂ Pipeline

Christopher Nwimae* Prof. Nigel Simms

School of Applied Science, Cranfield University, Cranfield, Bedfordshire, MK430AL, UK

The research is financed by Dr Ledee Namene Loolo (Medical Director, Pearl Clinic & Maternity).

Abstract

In this paper we investigate the increasing atmospheric concentration of carbon dioxide originating from human activities which include burning fossil fuels for heat and electricity generation, and combustion of other fuels in industry lead to greenhouse gases (GHG) mainly CO₂ which has an impact on the global climate warming. It is necessary to scale down the impact of these gases on the global climate by minimizing or preventing greenhouse gas emission to the atmosphere. Carbon capture and storage (CCS) from the source or power plant will help in reducing the emission of CO₂ from the atmosphere with the means of transporting the gas through the pipeline from the captured sources or power plant to storage sites underground or for enhanced oil recovery (EOR). However, this gas has some contaminant or impurities which affect the mechanical and chemical properties of the pipeline system during transportation. This paper examines various contaminants such as CO₂, H₂S, CO, NO_x, SO_x, and H₂O in carbon dioxide transmission pipelines with a particular focus on assessing how the contaminants causes corrosion in the pipeline and also considered materials that can be used as alternative to carbon steel for CO₂ transportation pipeline. The materials examined ranges from weldable 13%Cr super modified martensitic stainless steel, 22%Cr duplex and 25% Cr super duplex stainless steel, 316L clad pipe or Lined carbon steel and nickel alloy, and some parameters in materials selection were examined. The alternative materials considered are 13 %Cr super-modified martensitic stainless steel, and 25 %Cr super-duplex stainless steel.

Keywords: CO₂ Corrosion, CO₂ Contaminant, Material Selection.

DOI: 10.7176/JEP/10-12-19

Publication date: April 30th 2019

1. Introduction

Carbon dioxide (CO₂) is an important compound in the earth's atmosphere Kybell [21] Studies have shown that about one part per million per year Kongshaug and Seiersten [19]. Carbon dioxide lets light energy into since the nineteenth century concentrations of carbon dioxide in the atmosphere have increased at the rate of the atmosphere but does not let all the heat energy out, resulting in rising global temperatures. The increasing atmospheric concentration of CO₂ originates from human activities including burning fossil fuels for heat and electricity generation, and combustion of these fuels in other industries. CO₂ is emitted into the atmosphere during manufacturing, oil and gas production processes, power generation and from other sources. The carbon used in such operations leads to greenhouse gases (GHG) mainly CO₂ which impact on the global climate warming. It is necessary to scale down the impact of these gases on the global climate by minimizing or preventing greenhouse gas emissions to the atmosphere Kermani and Daguerre [16] carbon capture and storage (CCS) technology is one major solution that has been proposed by industry, government and other energy operatives worldwide to reduce the emission of CO₂ from the atmosphere Lucci et al., [22]. For CCS to be viable there is a need for reliable and safe transportation systems for CO₂, from its sources (capturing plants) to storage sites underground, such as depleted oil and gas fields (Figure 1)

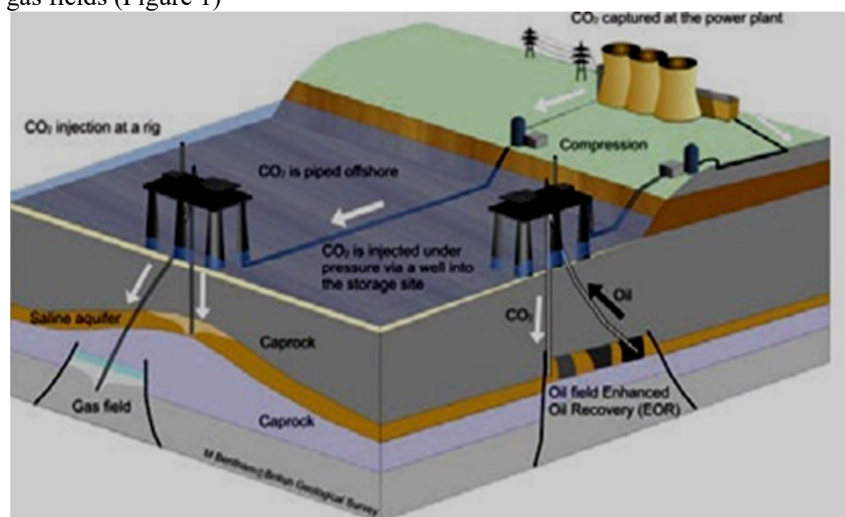

Fig 6 Carbon Captured Transportation and Storage Site [22]

There are several methods of CO₂ transportation such as shipping, train and tanker Seevam et al., [31] The cost of transporting CO₂ using the above mentioned methods is quite expensive and involves more logistics than transportation by pipeline. Ship transportation becomes competitive with pipeline when it involves long distances. According to the international panel on climate change (IPCC), carbon capture and storage (CCS) cite a break even distance of 1000km for transporting 6 metric tons of CO₂ in a year by pipeline and ship Seevam et al., [31], pp3.

However, the change does not depend on distance alone but the cost involved in shipping of CO₂. Choi et al., [8]. Pipeline has been adopted as the most adequate and cost effective solution for CO₂ transportation in favour of the other transportation means mentioned above. Pipeline is the most reliable option for large scale CO₂ transportation, for example transporting CO₂ from power stations of 400 to 500 MW Kermani and Daguerré [16]. Currently about 40 to 50 million tons of CO₂ per year is being transported through 3100km high pressure CO₂ pipeline in North America Kermani and Daguerré [16]. This CO₂ is captured from underground sources and transferred to depleted oil and gas fields for enhanced oil recovery (EOR). Another, example is, the Wayburn pipeline in Canada which was the first large integrated CO₂ pipeline used for capture, transmission, storage and enhanced oil recovery (EOR) Kermani and Daguerré [16]. However, these pipes are oil and gas pipelines and are made of carbon steel in accordance with their specifications and standards that must take in to consideration properties such as strength and toughness, for example: steel yield strength is 555 MPa for European standards and 900 MPa and above for international standards Lucci et al., [22].

In recent times, Lucci et al., [22] such pipelines have been used for CO₂ transportation in different parts of the world, running through desert, land and sea depths of 2200 to 3000m Lucci et al., [22]. The most important issue in CO₂ pipeline transportation is the operational life of the pipe which is based on several assumptions. Firstly, strength for oil and gas pipes, secondly whether the pipe can withstand the aggressiveness of the liquid CO₂ contaminants because no specification or standard for CO₂ pipeline design exist Lucci et al., [22].

This paper Choi et al., [8] have shown that carbon steel pipeline used in transporting carbon dioxide is susceptible to fracture and corrosion due to some contaminants or impurities associated with flue gases getting into the CO₂. These contaminants are (CO₂), (CH₄), (N₂), (H₂S), (C₂+), (CO), (NO_x), (SO_x), (H₂), (A_r), (S), (O₂), and other contaminants or impurities that cause the formation of corrosive products on the internal surfaces of a pipe Choi et al., [8]. The existing carbon dioxide pipelines were not designed to deal with the discharge of impurities or contaminants from the power, manufacturing or oil and gas production plant, these contaminants have a large impact on the chemical and physical properties of the CO₂ and, therefore, affect the lifespan of the pipeline material Spinelli et al., [33]. The issue of the contaminants or impurities in CO₂ which form a major part of this paper and will be describe subsequently.

This paper aims to identify the potential for corrosion damage from contaminated carbon dioxide in oil and gas pipelines (carbon steel), and will consider alternative materials that could be used for carbon dioxide pipelines and

How the impact of carbon dioxide (CO₂) contaminants from carbon capture and storage causes corrosion in carbon steel pipe.

2. Carbon Capture and Transporting Methodology

This paper Kermani and Daguerré [16] discusses the emission of carbon dioxide threatens the global climate, resulting in calls for carbon mitigation; consequently, there has been a surge in campaigns for clean fuel and CCS technology. The reasons for clean fuel technologies are:

- Energy demand is forecasted to rise by 50% over the next 25 years and hydrocarbons and coal are expected to play a significant role to satisfy increasing global energy demand.
- The need to scale down global CO₂ emission below 50% and to stabilize the emission of CO₂ to 550ppm.
- A United Kingdom Government target to scale down greenhouse gases production by 80% before 2050.

2.1 CO₂ capture

CO₂ capture is a set of technologies that can be applied to oil and gas flue system, coal and gas powered plants and other industrial processes in order to reduce CO₂ emission. There are several capture methods possible at present, but with significant penalties. One of the methods by which CO₂ emissions can be scaled down is by increasing the power plants efficiency or switching to natural gas from coal. However, these steps alone cannot achieve the required scaling down of CO₂ emission. Carbon Capture and Storage (CCS) from fossil fuel combustion will play a major part in solving the problem.

The CO₂ capture process can be divided into three categories such as post- combustion, pre-combustion and oxy-fuel combustion Billingham et al., [6]; Kermani and Daguerré [16].

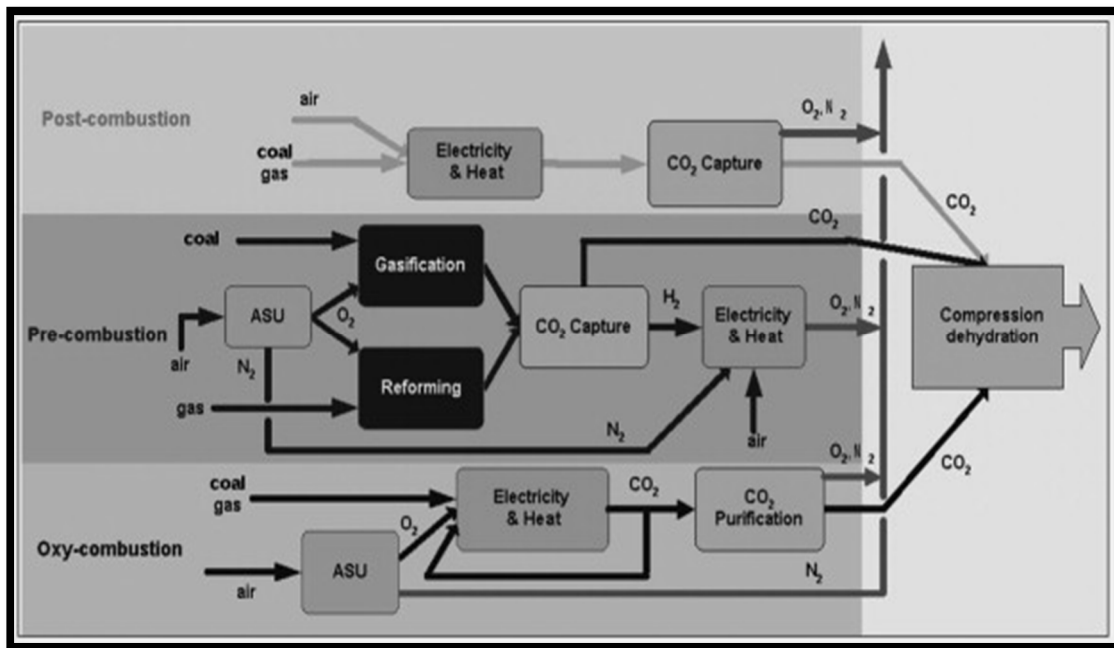
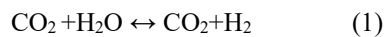

Fig 7 CO₂ Capturing Process Model Source: [14]

- **Post combustion capture:** this method is for separation of CO₂ from flue gases at the end of combustion process. The post combustion capture technique is appropriate to fit into existing power plant such as those in petrochemicals industry and can be used to treat CO₂ from other sources. This technique is established to use amine scrubbing method for separation of flue gases.
- **Pre-combustion capture:** this method involves production of synthetic gas, which is primarily a mixture of H₂, CO₂ and CO that is generated from reformation of natural gas or gasification of coal. This can be achieved through pre-combustion capture. In this method the fuel reacts in a high pressure with oxygen, air or steam to create CO and H₂. The CO is then converted CO₂ and H₂. The CO₂ will then be separated from H₂ and used as fuel.



- **Oxy-fuel combustion capture:** CO₂ concentration in flue gas can be increased through using pure or enriched oxygen as an alternative to air: this CCS methods has the advantage of generating flue gas with higher amounts of CO₂ than the conventional method of combustion. The carbon capture unit is positioned downstream of the oxy-fuel combustion unit and the flue gas desulphurization unit in the plant will remove the SO_x and NO_x as acids including water and other components in the gas stream, such as Ar, N₂ and O₂ will then be removed from the CO₂ stream through cryogenic separation. Consequently, the CO₂ capture method and its execution varies from plant to plant, as do the contaminant. See Table 1 and Figure 2

Table 1 Captured Impurities from Different Combustion Process [22]

COMPOSITION	POST COMBUSTION	PRE- COMBUSTION	OXYFUEL
CO ₂	>99% v%	>95.6 v%	>90v%
CH ₄	<100ppmv	<350ppmv	0
N ₂	<0.17 v%	<0.6 v%	<7 v%
H ₂ S	Trace	<3.4 v%	trace
C2+	<100ppmv	<0.01 v%	0
CO	<10ppmv	< 0.4 v%	trace
O ₂	<0.01 v1%	Trace	<3 v%
NO _x	< 50ppmv	0	< 0.25v%
SO _x	<10ppmv	0	<2.5 v%
H ₂	Trace	<3 v%	Trace
Ar	Trace	< 0.05 v%	< 5 v%
S	N/A	N/A	N/A

2.2. CO₂ Transportation through carbon steel pipeline

This paper Papavinasam et al [28] discusses the phase diagram for pure CO₂ which has two special points: the triple point and the critical point. Based on pressure and temperature, CO₂ can exist in the triple point as solid,

liquid or gas. Above the triple point is the critical point where CO₂ exists as a supercritical phase. Dense phase is a term used to characterize CO₂ in supercritical or liquid phase. In transporting CO₂ through pipelines the dense phase is accepted because in this phase it has a density that is similar to the liquid phase, but its viscosity is roughly equal to that of gas phase CO₂. Thus, in transporting CO₂ in dense phase the volume is low and pressure loss is low compared to gas phase transmission. Consequently, it is economical when transporting CO₂ in dense phase to use small diameter pipelines. However, when dense phase CO₂ is transported using pipelines impurity concentrations increase. Similarly, Seevam et al [31], the existence of impurities in CO₂ transmission causes a significant effect on parameters which cause a drop in pressure, temperature, viscosity and density. However, the degree to which temperature, pressure and other parameters increases is dependent on the combination, quantity or types of impurities present. The combination of some impurities in CO₂ causes higher pressure and temperature drops in the pipeline than other impurities, particularly if H₂O and NO_x are present. The existence of these impurities is also significant for the distance between the booster points along the pipeline, which are needed to keep the pressure high enough to enable CO₂ to continue in the dense phase. However, this paper has shown that there is currently no European code or standard for CO₂ pipeline design. The current pipeline codes and standards used for transporting hydrocarbons and gas require verification of whether they can cover the operational and design concern of CO₂ transmission from captured plant to storage site Lucci et al., [22].

2.3. Impact of CO₂ contaminant in carbon steel pipeline

In this paper Kermani and Daguerre [16] transporting CO₂ with contaminants such as CO₂, CH₄, N₂, H₂S, C₂₊, CO, O₂, NO_x, SO_x, H₂, Ar, S, is a problem for the pipeline, in particular, SO₂, SO₃ and O₂, which have a significant impact on the pipeline. However, it is noted that the contaminants in CO₂ mixtures is different depending on the method and source of capture Lucci et al., [22]. Again, Study have shown that, the absence of water integration with impurities will prevent corrosion in the pipe. However, the presence of water in the pipeline with the combination of SO₂, SO₃, O₂ and other acidic gas such as CO₂ and H₂S, will cause corrosion formation in the pipe. This is an important issue with CO₂ transmission pipelines. In situations like this, a more sensible approach needs to be adopted and thermodynamic analyses need to be carried out to ensure that there is no water in the transported CO₂ to enable the pipe to operate up to its design life specification. However, ideally, CO₂ should not be transported through pipelines with the above mentioned contaminants because of their potential to corrode the pipeline which can cause rupture to the pipeline and also should not be injected with contaminants for Enhanced Oil Recovery (EOR), to avoid corrosion formation in the casing pipe, except if studies prove otherwise. The best option is to dehydrate water or remove contaminants from the pipeline system before transporting to avoid corrosion so the pipeline can live for its design life Kermani and Daguerre [16]. The major technical limitation is the maximum acceptable contaminant in CO₂ that can be injected and the type of contaminant or impurities that are acceptable from corrosion and safety (rupture) in pipeline transportation. An experimental recommendation established as a result of the work that was done by European project (DYNAMIS) is given in Table 2; Alstom compiled and published reference data in Table 3 for tolerances to a range of contaminants or impurities with reverence to corrosion, health and safety, EOR, and storage. The large difference seen in these specifications is reasonable as the impurities in the Carbon Capture and Storage (CCS) stream depend on the fuel type and energy conversion method (post-combustion, pre-combustion or oxy-fuel) and capture method Dugstad et al, [10].

Table 2 DYNAMIS Recommendation of CO₂ Quality [10]

Component	Concentration	Limitation
H ₂ O	500 ppm	Technical: below solubility limit of H ₂ O in CO ₂ . No significant cross effect of H ₂ O and H ₂ S, cross effect of H ₂ O and CH ₄ is significant but within limits for water solubility.
H ₂ S	200 ppm	Health & safety considerations
CO	2000 ppm	Health & safety considerations
O ₂ ²	Aquifer < 4 vol%, EOR 100 – 1000 ppm	Technical: range for EOR, because lack of practical experiments on effects of O ₂ underground.
CH ₄ ²	Aquifer < 4 vol%, EOR < 2 vol%	As proposed in ENCAP project
N ₂ ²	< 4 vol % (all non condensable gasses)	As proposed in ENCAP project
Ar ²	< 4 vol % (all non condensable gasses)	As proposed in ENCAP project
H ₂ ²	< 4 vol % (all non condensable gasses)	Further reduction of H ₂ is recommended because of its energy content
SO _x	100 ppm	Health & safety considerations
NO _x	100 ppm	Health & safety considerations
CO ₂	>95.5%	Balanced with other compounds in CO ₂

Concentration of non- condensable gases on the table such as O₂, CH₄, Ar and N₂ should not go above 4% vol

Table 3 Alstom, Tolerance for CO₂ Quality [10]

Component	TOLERANCE	
	Low	High
CO ₂ (%)	>90 (STORAGE)	> 95 (EOR)
H ₂ (%)	< 4 (EOR)	< 4 (EOR)
N ₂ (%)	< 4 (EOR)	< 4 (EOR)
Ar (%)	< 4 (EOR)	< 4 (EOR)
CH ₄ (%)	< 4 (EOR)	< 5 (EOR)
O ₂ , PPM (V)	< 10 (Unclear)	< 1000 (Unclear)
H ₂ O PPM (V)	< 10 (Corrosion)	< 600 (Corrosion)
CO, PPM (V)	< 100 (H&S)	< 40000 (EOR)
NO _x PPM (V)	< 100 (H&S)	< 1500 (Unclear)
SO _x , PPM (V)	< 100 (H&S)	< 1500 (EOR)
H ₂ S, PPM (V)	< 100 (H&S)	< 15000 (EOR)
Particulates (mg/ Nm ³)	<0.1 (EOR/STORAGE)	<10 (EOR/STORAGE)

2.4. CO₂ Impact on corrosion in carbon steel pipeline

In this paper Ayello et al., [5] pipelines are currently used, by many different organizations, to transport CO₂ between gas treatment service facilities and Enhanced Oil Recovery (EOR) sites. The longest pipeline so far used for this purpose is the 800-kilometer Cortez pipeline that is operated by Kinder Morgan Ayello et al., [5]. Although, longer pipelines, to transport CO₂ from dissimilar sources with dissimilar types of concentrated impurities will be needed for the future operation for Carbon Capture and Storage (CCS). However, the effect of the impurities on the internal corrosion of carbon steel is largely unknown. Unlike that of natural gas, no accepted gas quality is specified for CO₂ Ayello et al., [5]. Choi et al [8], carbon steels pipes are susceptible to corrosion of flue gas due to the presence of some contaminants such as CO₂, H₂O, O₂, SO₂ and other elements that are capable of causing formation of corrosion products. Similarly, it has been observed that when CO₂ is transported through carbon steel pipeline in the dry phase it does not corrode the pipe material. Thus, corrosion will occur if there is free water present because CO₂ reacts with water to form carbonic acid (H₂CO₃). Hence, there should be a drying technique to remove water from the pipeline stream to prevent free water break-out. The maximum acceptable moisture in the pipeline is linked to the solubility of CO₂ in water. The prerequisite of CO₂ pipeline, used for Enhanced Oil Recovery (EOR) in United States of America, is a maximum of 600 ppm mole of water Choi et al., [8]. However, thermodynamic modelling for water solubility in CO₂ indicates the critical limit of free water precipitation to be roughly 2000 ppm mole in pressure and temperature range of 15 to 85 °C and 73 to 300 bars Choi et al., [8]. In corrosion, water acts as an electrolyte, solvent or reactant to dissolved gases such as CO₂, SO₂, and O₂. O₂ is a vital compound in corrosion as it provides the cathodic reaction path that enables corrosion advance and also inhibits some formation mechanisms with protective iron carbonate (FeCO₂ or FeCO₃). SO₂ has high water solubility, which results in the formation of sulfurous acid (H₂SO₃). As with CO₂, SO₂ does not cause corrosion without water or moisture. Suggestion has been made that corrosion rates will be acceptable as long as moisture or water content is about 50 mole ppm in the presence of SO₂ Choi et al., [8]. Although, the impact of CO₂ corrosion on carbon steel has been reviewed widely at pressures applicable to oil and gas transportation (up to 20 bar of CO₂), little information is available for high CO₂ partial pressure and experimental data is scarce for higher pressures. In addition, when O₂ and SO₂ impurities are present in CO₂ transmission lines, such as pipelines, there may be an increase in corrosion risk and this should not be discarded or neglected. Reviewing this papers Kermani and Daguerre [16], Choi et al., [8], Ayello et al., [5] and Choi et al., [9], have shown that the corrosion property of carbon steel has been investigated using an autoclave experiment system to simulate CO₂ conditions during transmission through pipelines with impurities from carbon capture and storage (CCS) applications. In this paper Dugstad et al.,[10] when the design philosophy of CO₂ pipeline was discussed it was generally accepted that CO₂ must be adequately dry to avoid drop-out of divergent aqueous phase in some part of the pipe, because free water causes hydrate formation and corrosion. Though, there was no agreed target on what the water concentration should be. It was argued that dehydration should be done down to 50 ppm before transporting through pipeline. This limit was specified for the first CO₂ pipelines in the United State of America and the Snøhvit3 pipeline in Norway Dugstad et al., [10]. See Table 2 for more specifications. Despite the target concentration, if there is unexpected water ingress in to the pipelines, the continuous flow of the dry CO₂ will allow the water to be dissolved rapidly and there will be no serious effect on the integrity of the pipeline unless there is an ample amount of salt precipitation which will cause under deposit corrosion if the salts are adequately hygroscopic. In addition, if there is continuous ingress of water to the pipeline or the pipeline is shut down after water ingress, the pipeline will generate corrosion product, it is essential to remove water from the pipeline before shutting down. Removing water from the pipeline involves depressurization of the pipeline which will take days or weeks. The acceptable time to

react after water ingress is system specific, which is based on the corrosion rate or allowable corrosion. Currently, the corrosion rate in pipelines experiencing unexpected water ingress cannot be predicted correctly as a result of lack of corrosion data Dugstad et al., [10]. Recently, a conventional approach adopted by the DYNAMIS project and Alstom to ensure the integrity of pipeline carrying CO₂. Table 2, emphasizes the strict impurity content requirements in CO₂ pipeline streams. These requirements involve the need to implement supplementary processing equipment, like H₂O drying and O₂ removal processing equipment downstream of the capture plant to facilitate the achievement of the CO₂ specification Dugstad et al., [10]. Studies have shown that severe corrosion damage occurs as a result of the presence of free water phase. It must also be noted that solubility of water in carbon dioxide is based on pressure and temperature. Figure 4

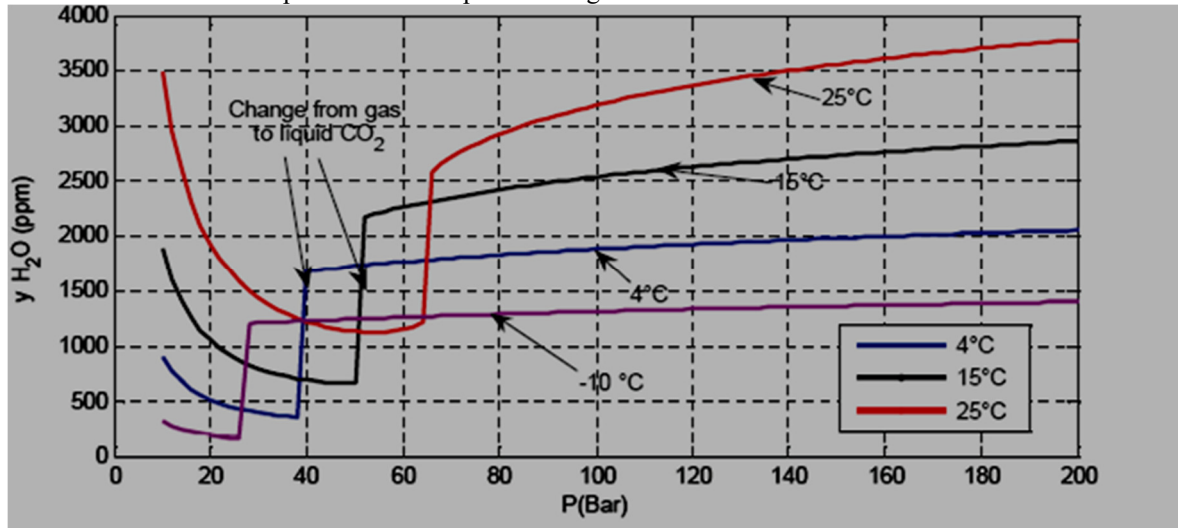

Fig 3 Solubility of H₂O in CO₂ versus Temperature and Pressure [22]

Studies have shown that in the absence of water, CO₂ does not cause corrosive attack on the internal surface of pipelines. Example (Figure 5)

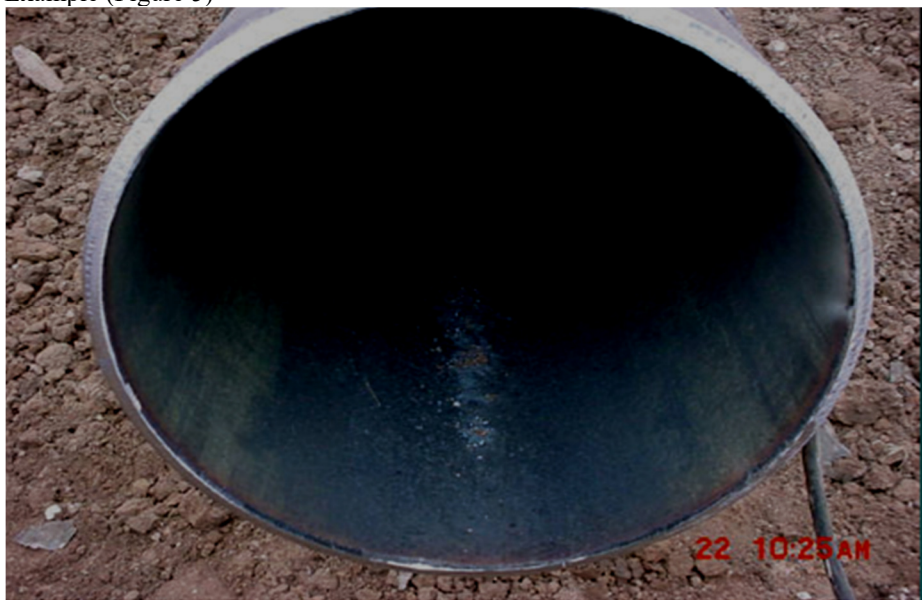

Fig 4 Internal Surface of a Pipeline Which Has Operated for Several years Without Free Water [22].

The French integrated oxy-combustion carbon capture and storage project for Lacq field17, which is the first CO₂ injection pipeline in France, the pipeline transports CO₂ to a gas depleted reservoir. This operation started in 2008 and it involves dehydration of water from a CO₂ rich gas with some impurities to give a typical gas composition of 92.0% CO₂, 4.0% O₂, 3.7% Ar and 0.3% N₂, carbon steel pipes are used to inject this gas. The CO₂ gas is dehydrated and there have been no corrosion phenomena in the existing Carbon Steel pipeline Kermani et al., [16]. Though, other factors or parameters can influence corrosion in CO₂ transmission pipelines. However, this paper is focusing solely on the impact of CO₂ contaminants from CCS on the corrosion of carbon steel pipes and alternative pipe materials.

3. CORROSION RESISTANT ALLOY MATERIALS FOR CO₂ TRANSPORT

The process of selecting pipeline material for CO₂ transportation, the primary concern is the performance of the material with respect to mechanical properties, corrosion performance, availability, weldability, and cost Marsh et al., [24] Materials selection is one of several ways of mitigating CO₂ corrosion but it is not an easy task to select the best corrosion resistance material for construction. Because of an industrial tendency toward low cost material development Koplaku et al [20] it is even more essential to select the required alternative material for CO₂ pipeline. The effect of CO₂ corrosion is an important issue for pipeline materials since the existing pipelines were not designed originally for CO₂ transportation. The second concern in material selection is installation technique, which could be limited depending on manufacturing route of line pipe that is chosen Marsh et al., [24]. In this paper, It is shown that the existing pipeline used for CO₂ transportation is carbon steel with a standard grade API 5L ISO 3183 Lucci et al., [22]; Jain.K.R, [13]. The commonly used carbon steel pipe in the oil and gas industry is graded in X52, X60, and X65, with minimum yield strength of 358 MPa (52,000 psi), 413 MPa (60,000 psi), and 448 MPa (65,000 psi) respectively Jain.K.R, [13]. These standard grades are given in SI Units. Carbon steel pipelines have some advantages which make them fit for purpose, such as availability, weldability, excellent mechanical properties, resistance to hydrogen induced stress cracking (HISC), ease of fabrication, but with a major disadvantage of susceptibility to general corrosion Kermani et al., [16]; Lucci et al., [22]; Jain.K.R, [13]; Choi and Nešić, [9]

In this paper four different corrosion resistant alloy (CRA) materials will be looked at as an alternative to carbon steel pipelines. They include:

- AISI 420 (UNS S42000) Super 13%Cr Modified Martensitic stainless steel
- 316L clad pipe (UNS S31603) or Lined carbon steel
- 22%Cr duplex stainless steel and 25%Cr super duplex stainless steel
- Nickel alloy, (alloy 825 UNS NO8825 and alloy 625 UNS NO6625)

A few papers (Marsh et al., 2010; Hara et al., 2000; Schofield et al., 2004; Kimura et al., 2004; Choi et al., 2010; Marsh, 2012) have reported laboratory and field experiments on AISI 420(UNS S42000) 13% Cr modified martensitic stainless steels, 316L clad pipe (UNS S31603) or Lined carbon steel and 22%Cr duplex stainless steel, 25%Cr super duplex stainless steel pipeline.

3.1. AISI 420 (UN S42000) Super 13%Cr modified martensitic stainless steel

Super 13%Cr modified martensitic stainless steel is preferred as one of the alternative materials for CO₂ transportation pipeline because of its mechanical strength at high pressure and temperature, its low cost, and corrosion resistance alloy Rogne et al.,[29]; Marchebois et al., [23]. This steel was recently developed by a steel manufacturer, it contains Nickel, the most efficient alloying element, and molybdenum which increases temperature and corrosion resistance Hara et al., [11]; Marchebois et al., [23]. This steel is referred to as weldable 13% Cr super modified or (lower carbon) martensitic stainless steel and is resistant to sweet corrosion compared to the conventional 13%Cr martensitic stainless steel grades Marchebois et al., [23]. Welding qualification procedure has been developed for super 13% Cr modified martensitic stainless steel Rogne et al., [29], and this paper have shown that the conventional 13% Cr martensitic stainless steel has been in use for several years as one of the alternative materials to carbon steel, though, this steel was quite expensive for industrial use Rogne et al., [29]; Marchebois et al., [23].The quest for less expensive material with good mechanical strength and corrosion resistance led to the development of AISI 420 (UNS S42000) 13% Cr modified martensitic stainless steel. This has high specified minimum yield strength (SMYS) of 550 MPa, CO₂ corrosion resistance, and lower carbon content than the conventional 13%Cr martensitic stainless steel. The development of the AISI 420(UNS S42000) 13%Cr modified martensitic stainless steel has filled the gap between the conventional 13%Cr martensitic stainless steel and other high corrosion resistant alloys Marchebois et al., [23]. In addition, this steel has excellent internal corrosion and cracking resistance Marsh et al., [24]; Marsh [25] but the Super 13%Cr martensitic stainless steel has some advantages such as low cost, high strength carbon resistance alloy, corrosion resistance in high temperature and pressure, excellent mechanical property, and weldability. However, this steel, with a pitting resistance equivalent number (PREN 20), has a limited resistance to hydrogen induced stress cracking (HISC) and sulfide stress cracking (SSC) as compared to carbon steel pipeline Marsh et al.,[24]; Marsh [25].

3.2. 316L clad pipe (UNS S31603) or Lined carbon steel

This papers Kloewer et al., [18]; Marsh,[25] have shown that 316L (UNS S31603) is a good cladding material, though its mechanical strength is derived from carbon steel pipe. Its corrosion resistance ranges from 2 to 3 mm Kloewer et al., [18]; Marsh,[25] 3 to 5 mm Marsh et al., [24]; and 10 to 20 mm Yoshino et al [34]; This implies that the cladding material corrosion resistance thickness ranges from 2 to 20 mm and the clad pipe offers good mechanical strength in addition to corrosion resistance. The outer layer of this pipe is covered with carbon steel pipe of acceptable or suitable grade based on an ISO standard Kloewer et al.[18]; Marsh et al.,[24]; Marsh [25.] 316L clad (UNS S3163) is used as an alternative material to super 13%Cr modified martensitic stainless steel.

Clad steel pipe has mechanical strengths which are adequate to resist highly corrosive environments. It has an improved corrosion resistance when compared to super 13%Cr modified martensitic stainless steel (MMSS) because its pitting resistance equivalent number is high (PREN 25). The disadvantage of this material is the temperature limit which ranges from 40 to 60°C when operating in sour environment with chloride of >5000 ppm Marsh,[25]; Marsh et al., [24]; Kloewer et al.,[18]; and Nødland [26]. This temperature limit is given by ISO 15156 and is considered by other operators Marsh et al.,[24]; Marsh, [25]. This has led to testing of these materials in specific fields by some operators to verify the temperature performance limit. This paper has shown that thermal stress is generated when clad pipes are in operation because the temperatures in the flow line are in the range of 40 to 60°C Yoshino et al., [34], If thermal expansion of cladding material is higher than the backing steel it might generate compressive stress in the cladding and that will lower the risk of stress corrosion cracking in clad pipes. However, precaution should be taken to avoid positioning the longitudinal seam position at the bottom because corrosion might occur as a result of the action of residual stress on the weld metal at the bottom Yoshino et al., [34]. Research have shown that some operators have started using this material UNS N08904 as an alternative to UNS S31603 because of its improved pitting resistance equivalent number (PREN 35), though the usage is limited to some operators because they prefer using other material such as Nickel alloys UNS N08825 or UNS N06625 Marsh et al.,[24]; Marsh [25].

3.3. 22%Cr duplex and 25%Cr Super duplex stainless steel

This paper Marsh [25]; discuss and shown how Duplex stainless steel is a material that has an excellent corrosion resistance alloy, high strength, toughness and ductility. Duplex stainless steel has 22%-25% chromium content and a lower nickel content than austenitic stainless steel. This material has been in use for several years as an alternative material to carbon steel and can also be used as an alternative to the materials discussed above in a corrosive, erosion and sour service environment where the above mentioned materials cannot operate Marsh [25]; Marsh et al.,[24]; Shargay [32]; Rogne et al., [29]. However, 22%Cr duplex stainless steel has some advantages such as corrosion resistance, high pitting resistance equivalent number (PREN >30) and erosion, with high specified minimum yield strength (SMYS) which ranges from 450 to 600 MPa for 22%Cr with tensile strength of 620 MPa for 22%Cr Duplex Stainless Steel compared to order materials mention above. It can also be used in high sour service tolerance temperature of about 232°C Marsh [25]; Marsh et al., [24], Olden et al., [27]. The disadvantage of this material is its susceptibility to cracking of various types such as chloride stress cracking in high salinity Environments and hydrogen induce stress cracking (HISC), hydrogen brittle in weld. Also, it is expensive compared to others, difficult to weld, and suffers temperature de-rating at elevated temperature Marsh [25]; Marsh et al.,[24]; Olden et al., [27]; and An and Dobson [4]. This material can fail under evaporating conditions with temperature of 120-140°C Marsh [25]; Marsh et al., [24]. Experiment has also shown that 25%Cr super duplex has an improved corrosion resistance, improved H₂S tolerance and a more higher pitting resistance equivalent number (PREN >40) than 22% duplex stainless steel. This means that if improved corrosion resistance and H₂S tolerance materials are needed, 25%Cr super duplex stainless steel is better than other available options. This material is also tolerant in salinity environments and is not immune to chloride stress cracking (CSC). Another advantage of this material is its improved specified minimum yield strength (SMYS) which ranges from 550 to 700 MPa for 25%Cr Super Duplex Stainless Steel with tensile strength of 700 MPa for Super Duplex Stainless Steel. Though these materials are susceptible to hydrogen induce stress cracking (HISC) that emanated from cathodic protection. To mitigate the risk hydrogen induced cracking, systems need to be designed within DNV-RP-F112 requirement Marsh [25]; Marsh et al., [24]; and An and Dobson [4].

3.4. Nickel Alloy, Alloy 825 (UNS NO8825) and Alloy 625 (UNS NO6625)

In this papers Aberle and Agarwal [1]; Hibner and Shoemaker [12] Alloy 825 (UNS NO8825) and Alloy 625 (UNS NO6625) are high content nickel alloys with chromium and molybdenum. Alloy 625 is a high temperature application material and can also be used as a wet corrosion application material. This alloy contains niobium which makes the age harden Aberle and Agarwal [1]. Alloy 825 is a titanium stabilized nickel-iron- chromium with copper and molybdenum. The molybdenum content is 3.2% less than that for alloy 625 molybdenum. These alloys have good corrosion resistance behaviour to carbon dioxide corrosion, sour service corrosion, sulphide stress corrosion cracking, and chloride stress cracking Marsh [25]; Marsh et al., [24]; Aberle and Agarwal [1]; Hibner and Shoemaker [12]. Nickel Alloy 625 (UNSN06625) has high chromium and molybdenum content than 825 (UNS NO8825), with a pitting resistance equivalent number (PREN >50). It is excellent in terms of corrosion resistance. Alloy 825 (with PREN around 30) is considerably cheaper but has some disadvantage such as low protection to crevice corrosion Marsh [25]; Aberle and Agarwal [1]. Studies have shown that this alloy cannot be used for pipeline in a rigid form because it is too expensive. It can be used as cladding or lining materials for carbon steel pipelines Marsh [25]; Marsh et al. [24]; Aberle and Agarwal [1]. This paper has shown that the corrosion resistance of the corrosion resistance alloy (CRA) has Cr, Mo and N in it content and this is estimated or assess in the pitting resistance equivalent number (PREN). It was shown that the higher the (PREN) number the

better the corrosion resistance of the material to localized corrosion such as pitting or crevice corrosion Marsh [25]; Aberle and Agarwal [1].

$$PRE = \%Cr + 3.3 x \% Mo \text{ or } PRE = \%Cr + 3.3x\%Mo + 30x\%N \dots \dots \dots (2)$$

4. MATERIALS SELECTION FOR CO₂ TRANSPORT SYSTEM



In this paper the basic consideration in choosing an alternative pipeline material is the service requirements which revolve around the four factors mentioned above, mechanical properties, chemical properties, operating environment and the relative cost of the material. In order to make a clear cut choice a material selection matrix method is used. Table 4 and in Appendix A, Marsh et al., [24]; Chawla and Gupta, [7].

The following materials detailed below and shown in row 1 and 4 of table 4 and in table 1 (Appendix A) row 1 and 3 stand out as alternative materials to carbon steel for CO₂ transmission pipeline:

AISI420 (UN S42000) Super 13%Cr modified martensitic stainless steel is considered as an alternative to carbon steel owing to its low cost, good mechanical properties, excellent corrosion resistance in CO₂ environment, elevated temperature de-rating, improve weldability, sulfide stress cracking resistance (SSC). The reason for this choice is its outstanding properties such as low cost, lower carbon content which makes it weldable, elevated temperature de-rating which means this material can withstand high temperature and high pressure (HT/HP). This material is also playing an intermediate role between 22%Cr Duplex and other materials Marchebois et al., [23]; Rogne et al., [29]; Amaya et al., [3].

25%Cr Super duplex stainless steel is also considered as an alternative material to carbon steel. This material is an excellent corrosion resistant alloy, has excellent mechanical strength, with high pitting resistance equivalent number compared to other materials Marsh, [25]; Marsh et al., [24]; Shargay, [32].

4.1. Temperature de-rating/ mechanical strength

Studies have shown that Super 13%Cr modified martensitic stainless steel and 25%Cr super duplex stainless steel show a great advantage but 22%Cr duplex is the worst affected material in mechanical properties and temperature de-rating with regard to high pressure and high temperature (HP/HT) when compared with X65 carbon steel, but ideally super 13%Cr modified martensitic stainless steel is a good material for high pressure and high temperature (HP/HT) development, though it experiences a slight loss in mechanical strength in elevated temperature Hara et al., [11]; Marsh, [25]; Marsh et al., [24]; Kimura et al., [17].

Table 4 Comparison of Alternative Materials properties

Materials	Corrosion resistance	HISC	Pitting Attack	Chlorination Effect	Mechanical Strength	Weldability	Cost	Availibility	Temperature
13%Cr Super martensitic Stainless Steel	E	P	P	E	E	E	P	G	E
316L Clad or Carbon Steel	G	P	G	P	G	G	P	G	P
22%Cr Duplex stainless steel	E	P	G	E	E	G	P	G	G
25%Cr Super Duplex Stainless Steel	E	P	E	E	E	G	P	G	G
Nickel Alloy 825 (UNS NO8825)	G	G	P	G	G	G	P	G	G
Nickel Alloy 625 (UNS NO 6625)	E	E	E	G	G	G	P	G	G

E= Excellent

G= Good

P= Poor

5. GENERAL DISCUSSIONS

General corrosion in carbon steel pipeline is due to the presence of contaminants such as CO₂, CH₄, N₂, H₂S, C₂+, CO, O₂, NO_x, SO_x, H₂, A_r, S, in CO₂ from flue gas with some key contaminants such as CO₂, H₂O, O₂, H₂S, SO₂ that are capable of causing formation of corrosion product in CO₂ pipeline. However, CO₂ should not be transported through carbon steel pipeline with the presence of contaminant to enable the pipeline operate up to its design life. This paper consider the routing of a CO₂ pipeline and other service requirements for material selection AISI 420 (UNS42000) super 13%Cr modified martensitic stainless steel and 25%Cr super duplex stainless steel have been considered as alternative pipeline materials to carbon steel. These materials are good corrosion resistance alloys with high mechanical strength and can be used to transport carbon dioxide (CO₂) in liquid phase

with water even when conditions are above H₂O solubility limit. Selecting an alternative material for CO₂ transportation does not mean that carbon steel pipeline is prohibited from transporting carbon dioxide. Carbon steel pipeline is still the best and can still be used in transporting CO₂, but the CO₂ need to go through full dehydration process and transport in dry phase to avoid corrosion product in the internal surface of the pipeline see figure 6, pipeline used to transport CO₂ in dry phase for several years without water ingress. Carbon steel has good properties such as availability, low cost, Weldability, excellent mechanical properties, ease of fabrication and resistance to hydrogen induce stress cracking (HISC). In addition super 13%Cr modified martensitic stainless steel has excellent corrosion resistance alloy, good mechanical strength, good strength of retention in high temperatures, lower cost, improve Weldability, resistance to sulfide stress cracking resistance (SSC), though this material show a less resilient in corrosion and cracking resistance when in high chloride environments but it is susceptible to hydrogen induce stress cracking(HISC) and 25%Cr Super duplex is also an excellent corrosion resistance alloy, excellent mechanical strength, with high pitting resistance equivalent number compared to other materials but it is susceptible to hydrogen induce stress cracking. This paper also consider other materials such as Nickel alloy 625 and 825, 316L clad pipeline are mechanically lined or metallurgically boded clad pipelines materials with good corrosion resistance alloys but the issue is the lined option, because if the layer is disregarded there will be a rapid corrosion of carbon steel as a result erosion damage and it is also difficult to weld in the field.

5.1. Cost of Materials

Material costing was calculated based on the percent composition of the individual component in the alloys using the equation below and detailed calculation will be provided in appendix A.

$$C_{material} = \sum_{i=1}^n (C_i P_i) \quad (5-1)$$

Where;

- c = Cost,
- p = percentage of component
- i = Individual component

5.2. Life of Pipeline

The service life of pipeline is depended on the rate of internal and external corrosion, maintenance strategy used to assess corrosion and repair will allow the material to last longer than its service life. Materials with high corrosion resistance alloy such as Weldable 13%Cr modified martensitic stainless steel and 25%Cr super duplex stainless steel with higher corrosion resistant property are the best for the construction of CO₂ transportation pipeline and they have a useful long life in their operating environment. However, the use of non-corrosion resistance alloy will reduce the service live of the pipeline considering the high corrosion rate of CO₂. Considering the old oil and gas pipeline that is proposed for CO₂ transport, the service life of the pipeline would have been outlived before being put out of service for its original use. This would make the pipeline more vulnerable to corrosion failure when used to transport CO₂. Agarwala, [2].

6. Conclusion

This paper have discussed the various contaminants or impurities in CO₂ streams from CCS process and how they affect the pipeline and cause internal corrosion. The study also considers the materials that could be used as alternatives to carbon steel for carbon dioxide (CO₂) transmission pipeline. The following conclusions were made:

- The key contaminants that cause formation of corrosion product in CO₂ pipeline are CO₂, H₂O, SO₂, H₂S, and O₂.
- CO₂ is transported in a minimum operating pressure of 8 MPa and maximum operating pressure of up to 30 MPa which means the old oil and gas pipeline propose for CO₂ transportation cannot be used because the minimum pressure of transporting CO₂ is in the range of the maximum pressure of gas both in onshore and offshore.
- The alternative materials to carbon steel that have been identified are: (a) Weldable super 13%Cr modified martensitic stainless steel and (b) 25% Cr Super duplex stainless steel.
-

6.1 Recommendations

This study concentrated on the potential issue of corrosion damage; however it is recommended that pipeline integrity inspections should be carried out on old pipelines prior to deployment for CO₂ transport. For new pipelines, high corrosion resistance steels should be used to ensure satisfactory service life.

Secondly, high alloy steels should be used as cladding material where carbon steel is proposed to be used as base material and the welded joint should not be neglected. Also, there should be supplementary processing equipment in the downstream of the captured plant to dry H₂O and remove O₂ from CO₂ before transporting

through pipelines.

References

1. Aberle, D. and Agarwal, D. C. (2008), "High Performance Corrosion Resistant Stainless Steels and Nickel Alloys for Oil & Gas Applications", *CORROSION 2008*, 16-20 March, New Orleans, NACE International, Houston, Texas, Paper No. NACE-08085.
2. Agarwala, V. S. (2004), "Control of Corrosion and Service Life", *CORROSION 2004*, 28 March-1 April, New Orleans, NACE International, Houston, Texas, Paper No. NACE-04257.
3. Amaya, H., Hirata, H., Ueda, M., Mori, T. and Kondo, K. (1998), "Effect of Chromium and Molybdenum on Corrosion Resistance of Super 13Cr Martenitic Stainless Steel in CO₂ Environment", *CORROSION 98*, 22-27 March, San Diego, NACE International, Houston, Texas, Paper No. NACE-98113.
4. An, X. and Dobson, A. (2009), "An Influence of Cathodic Protection Potential On the Mechanical Properties of Super Duplex Stainless Steel Tube", *CORROSION 2009*, 22-26 March, Atlanta, NACE International, Houston, Texas, Paper No. NACE-09297.
5. Ayello, F., Evans, K., Thodla, R. and Sridhar, N. (2010), "Effect of impurities on corrosion of steel in supercritical CO₂", *CORROSION 2010*, 14-18 March 2010, San Antonio, NACE International, Houston, Texas, Paper No. NACE 10193.
6. Billingham, D. M. A., Lee, D. C., Haines, M. and Smith, D. L. (2012), "Corrosion And Materials Selection Issues In Carbon Capture Plants", *CORROSION 2012*, 11-15 March 2012, Salt Lake City, Utah, NACE International, Houston Texas, Paper No. NACE 1371.
7. Chawla, S. L. and Gupta, R. K. (1993), *Materials Selection for Corrosion Control*, ASM International, Materials Park, OH.
8. Choi, Y., Nescic, S. and Young, D. (2010), "Effect of impurities on the corrosion behavior of CO₂ transmission pipeline steel in supercritical – CO₂ water environments.", *CORROSION 2010*, March 14 - 18, San Antonio, NACE International, Houston, Texas, Paper No. NACE-10196.
9. Choi, Y. and Nešić, S. (2011), "Effect of Water Content On the Corrosion Behavior of Carbon Steel In Supercritical CO₂ Phase With Impurities", *CORROSION 2011*, 13-17 March, Houston, NACE International, Houston, Texas, Paper No. NACE 11377.
10. Dugstad, A., Clausen, S. and Morland, . (2011), "Transport of Dense Phase CO₂ In C-steel Pipelines - When is Corrosion an Issue?", *CORROSION 2011*, 13-17 March, Houston, NACE International, Houston, Texas, Paper No. NACE-11070.
11. Hara, T., Takahashi, A., Asahi, H. and Kawakami, A. (2000), "Effects of Alloying Elements on Carbon Dioxide Corrosion in 13% to 20% Chromium-Containing Steels", *Corrosion*, vol. 56, no. 4, pp. NACE-00040419.
12. Hibner, E. L. and Shoemaker, L. E. (2000), "The Advantages of Nickel Alloys for Seawater Service", *CORROSION 2000*, 26-31 March, Orlando, NACE International, Houston, Texas, Paper No. NACE-00629.
13. Jain, K. R. (Cranfield University), (2013), *Module On Pipeline Engineering* Cranfield, UK.
14. Kanniche, M., Gros-Bonnivard, R., Jaud, P., Valle-Marcos, J., Amann, J. and Bouallou, C. (2010), "Pre-combustion, post-combustion and oxy-combustion in thermal power plant for CO₂ capture", *Applied Thermal Engineering*, vol. 30, no. 1, pp. 53-62.
15. Kermani, B., Esaklul, K. A. and Martin, J. W. (2006), "Materials design strategy: Effects of H₂S / CO₂ corrosion on materials selection", *CORROSION 2006*, March 12 - 16, San Diego, NACE International, Houston, Texas, Paper No. NACE 06121.
16. Kermani, B. and Daguette, F. (2010), "Materials Optimization For CO₂ Transportation In CO₂ Capture And Storage ", *CORROSION 2010*, 14-18 March 2010, San Antonio, NACE International, Houston Texas, Paper No. NACE-10334.
17. Kimura, M., Sakata, K., Mochizuki, R. and Miyata, Y. (2004), "Corrosion Resistance Of Martensitic Stainless Steel OCTG In High Temperature And High CO₂ Environment", *CORROSION 2004*, 28 March-1 April, New Orleans, NACE International, Houston, Texas, Paper No. NACE-04118.
18. Kloewer, J., Behrens, R. and Lettner, J. (2002), "Clad Plates and Pipes in Oil and Gas Production: Applications - Fabrication - Welding", *CORROSION 2002*, 7-11 April, Denver, NACE International, Houston, Texas, Paper No. NACE-02062.
19. Kongshaug, K. O. and Seiersten, M. O. (2004), "Baseline Experiments for the Modeling of Corrosion at High CO₂ Pressure", *CORROSION 2004*, March 28 - April 1, New Orleans, NACE International, Houston, Texas, Paper No. NACE -04630.
20. Kopliku, A. and Cavassi, P. (2002), "Selection Of UNS N08825 As Cladding Material For Offshore Pipelines Transporting Sour Multiphase Hydrocarbon", *CORROSION 2002*, 7-11 April, Denver, Co, NACE International, Houston Texas, USA, Paper No. NACE-02042.
21. Kybell, B. (1995), "The Enhanced Greenhouse Effect And Climate, An Assessment", *Technical Meeting / Petroleum Conference Of The South Saskatchewan Section*, 16-18 October, Regina, Petroleum Society of

- Canada (PSC), Regina, Canada, Paper No. SPE-95-141.
22. Lucci, A., Demofonti, G. and Spinelli, C. M. (2011), "CO₂ Anthropogenic Pipeline Transportation", *The Twenty-first International Offshore and Polar Engineering Conference*, 19-24 June, Maui, The International Society of Offshore and Polar Engineers, Mountain View, California, Paper No. ISOPE-I-11-170.
 23. Marchebois, H., Leyer, J. and Orleans-Joliet, B. (2007), "Ssc Performance Of A Super 13% Cr Martensitic Stainless Steel For Octg: Three-Dimensional Fitness-For-Purpose Mapping According To PH₂S, Ph And Chloride Content", *CORROSION 2007*, 11 - 15 March, Nashville, NACE International, Houston, Texas, Paper No. NACE-07090.
 24. Marsh, J., Zvandasara, T., Macgill, A. and Kenny, J. (2010), "Materials Selection For HP/HT Developments", *SPE International Conference on Oilfield Corrosion*, 24-25 May, Aberdeen, Society of Petroleum Engineers, Houston, Texas, Paper No. SPE-130716-MS.
 25. Marsh, J. (2012), "Materials Selection for Offshore Pipelines - a European Perspective", *CORROSION*, 11-15 March, Salt Lake City, NACE International, Houston, Texas, Paper No. NACE-2012-1649.
 26. Nødland, S. (2009), "Large And Small Scale SSC/SCC Testing of 316L Clad At 135 °C", *CORROSION 2009*, 22-26 March, Atlanta, NACE International, Houston, Texas, Paper No. NACE-09364.
 27. Olden, V., Thaulow, C. and Johnsen, R. (2008), "Modelling of Hydrogen Diffusion and Hydrogen Induced Cracking in Supermartensitic and Duplex Stainless Steels", *Materials & Design*, vol. 29, no. 10, pp. 1934-1948.
 28. Papavinasam, S., Zanganesh, K., Li, J., Emadi, D., Doiron, A., Salvador, C., Krausher, J., Shafeen, A., Shi, C., Pratt, A. and Gravel, J. (2012), "Materials Issues In CO₂ Capture, Transport, And Storage Infrastructure", *CORROSION 2012*, 11-15 March, Salt Lake City, Utah, NACE International, Houston, Texas, Paper No. NACE- 1259.
 29. Rogne, T., Orjasaeter, O., Eggen, T. G., Nyhus, B., Svenning, M. and Lange, H. I. (2003), "Evaluation of Hydrogen Embrittlement of S13Cr Stainless Steels Based on SSR and CTOD Testing", *CORROSION 2003*, 16-20 March, San Diego, NACE International, Houston, Texas, Paper No. NACE-03534.
 30. Schofield, M. J., Evans, T., Nice, P. I. and Waterton, K. C. (2004), "Corrosion Behavior of Carbon Steel, Low Alloy Steel and CRA's in Partially Deaerated Sea Water and Commingled Produced Water", *CORROSION 2004*, 28 March-1 April, New Orleans, NACE International, Houston, Texas, Paper No. NACE-04139.
 31. Seevam, P., Downie, M. and Race, J. (2007), "Transport of CO₂ for Carbon Capture and Storage in the UK", *Offshore Europe*, 4-7 September, Aberdeen, Society of Petroleum Engineers, Richardson, Texas, Paper No. SPE 109060-MS.
 32. Shargay, C. A. (2005), "Applications of Duplex Stainless Steels in Refining - Overview of API 938C", *CORROSION 2005*, 3-7 April, Houston, NACE International, Houston, Texas, Paper No. NACE-05571.
 33. Spinelli, C. M., Demofonti, G., Biagio, M. D. and Lucci, A. (2012), "CO₂ Full Scale Facilities Challenges For EOR/CCTS Testing On Transportation Issues", *The Twenty-Second International Offshore and Polar Engineering Conference*, 17-22 June, Rhodes, The International Society of Offshore and Polar Engineers, Mountain View, California, Paper No. I-12-323.
 34. Yoshino, Y., Fukuda, T., Shimazaki, M. and Ohnishi, K. (1982), "Clad Steel Pipes for Transporting Corrosive Oil, Gas, and Seawater", *Offshore Technology Conference*, 3-6 May, Houston, Offshore Technology Conference, Houston, Texas, Paper No. OTC-4328-MS.

APPENDICES

Appendix A Calculation of material cost

Table 1 Comparison of Materials Cost

N ^o	MATERIALS	COST PER TON	SOURCE OF PRICE	SOURCE OF Ni,Cr,Mo,Fe Percentage
1	13%Cr Super Modified Martensitic Stainless Steel	\$2,116.00	www.alibaba.com	www.matweb.com
2	22%Cr Duplex Stainless Steel	\$3,088.40	www.alibaba.com	www.matweb.com
3	25%Cr Duplex Stainless Steel	\$3,671.80	www.alibaba.com	www.matweb.com
4	316L Clad	\$3,750	www.alibaba.com	www.matweb.com
5	Nickel 825 (UNS NO8825)	\$4,807.50	www.alibaba.com	www.matweb.com
6	nickel 825 (UNS NO6625)	\$7,123.60	www.alibaba.com	www.matweb.com

I = individual component

c=cost

p= percentage of component

$$C_{material} = \sum_{i=1}^n (C_i P_i)$$

13%Cr Super Modified Martensitic Stainless Steel	Cr	Mo	Ni	Fe
Percentage	13%	2.50%	6%	50%
Quantity	0.13	0.025	0.06	0.5
cost per ton	\$1,200	\$24,000	6000	\$2,000
Cost of Steel = $\sum (\$1200 \times 0.13) + (\$24000 \times 0.025) + (6000 + 0.06) + (2000 + 0.5)$	2116			
The cost of 13%Cr Super Modified Stainless Steel = \$ 2116/ton				

22%Cr Duplex stainless steel	Cr	Mo	Ni	Fe
Percentage	22%	3.00%	5.30%	69.52%
Quantity	0.22	0.03	0.053	0.6952
cost per ton	\$3,000	\$24,000	6000	2000
Cost of steel = $\sum (\$ 3000 \times 0.22) + (\$ 24000 \times 0.03) + (\$ 6000 \times 0.053) + (\$ 2000 \times 0.69.52)$	3088.4			
The cost of 22%Cr Duplex Stainless Steel = \$ 3088.4/ton				

25%Cr Super Duplex Stainless Steel	Cr	Mo	Ni	Fe
Percentage	25%	3.60%	6.50%	64.64%
Quantity	0.25	0.036	0.065	0.6464
Cost per ton	\$4,500	\$24,000	\$6,000	\$2,000
Cost of Steel = $\sum(\$ 4500 \times 0.25) + (\$ 24000 \times 0.03) + (\$ 6000 \times 0.065) + (\$ 2000 \times 0.6464)$	3671.8			
The Cost of 25% Super Duplex Stainless Steel = \$ 3671.8/ton				

Nickel 825 (UNS NO8825)	Ni	Cr	Mo	Fe
Percentage	42%	21.50%	3.00%	30%
Quantity	0.42	0.215	0.03	0.3
Cost per ton	\$ 6,000	\$ 4,500	\$ 24,000	\$ 2,000
Cost of steel = $\sum(\$ 6000 \times 0.42) + (\$ 4500 \times 0.215) + (\$ 24000 \times 0.03) + (\$ 2000 \times 0.3)$	4807.5			
The Cost of Nickel Alloy 825 (UNS NO 8825) = \$ 4807.5/ton				

Nickel 625 (UNS NO 6625)	Ni	Cr	Mo	Fe
Percentage	61.31%	23%	10%	0.50%
Quantity	0.6131	0.23	0.1	5.00E-03
Cost per ton	\$ 6,000	\$ 4,500	\$ 24,000	\$ 2,000
Cost of steel = $\sum(\$ 6000 \times 0.6131) + (\$ 4500 \times 0.23) + (\$ 24000 \times 0.1) + (\$ 2000 \times 10^{-3})$	7123.6			
The Cost of Nickel Alloy 625 (UNS NO 6625) = \$ 71,23.6/ton				

First Author Biographies ;(Christopher Nwimae)

I Christopher Deekia Nwimae, became a Student Member of America Society of Mechanical Engineering in 2013, a Student Member of Society for Underwater Technology in 2013, a Student Member of Society of Petroleum Engineers 2013 and a Student Member of Nigerian Society of Engineers in 2001. I was given an award by Nigerian Society of Engineers, Port Harcourt Branch Rivers State Chapter on the 19th September, 2006 and was the first award winning student of the Branch.

I was born in Opu-oko Town, Nyo-khana District of Khana Local Government Area of Rivers State, Nigeria on the 22nd day of November, 1982.

I started my educational career at sacred heart, primary school, Diobu , Port Harcourt, Rivers State, and later enrolled in Government Craft Development Center, Port Harcourt, Rivers State to study Welding and Fabrication. I later got admitted to Rivers State Polytechnic, Bori, Rivers State where I Obtained Ordinary National Diploma (OND) in Mechanical Engineering in 2002, I then had my Six month industrial training with TOTAL Nigeria Limited and my drive for education and my flair for knowledge got me admitted into the Rivers State University of Science and Technology Port Harcourt, Rivers State where I Obtained my Bachelor of Technology (B.TECH)

in Mechanical Engineering in 2008. I then proceeded to the prestigious Cranfield University United Kingdom where I Obtained a Master's degree in Subsea Engineering in 2016.

ACKNOWLEDGEMENTS

I want to start by appreciating The ALMIGHTY GOD who has made my dreams come true in life.

My profound gratitude goes to my supervisor Professor Nigel Simms for his contribution throughout my research work.

My profound gratitude goes to the sponsor of my Journal paper Dr. Ledee Namene Loolo