

Design of Off - Grid Solar Photovoltaic (PV) System for Cottage Hospital

Unwaha, J.I.^{1*} Jones, N. D. Musa, A.J.²

1 Department of Mechanical Engineering, Federal Polytechnic Mubi, Adamawa State

2 Department of Mechanical Engineering, Federal Polytechnic Damaturu Yobe State

Abstract

The provision of adequate and sustainable power supply to the country's citizen has been a mirage since the 1980's when the nation neglected to improve its power generation capacity. The rapid population and increase in industrial activities necessitate the injection of solar photovoltaic technology into nation's energy mix. The need to power cottage hospital in developing country like Nigerian is too enormous. This seminar paper is an attempt to design off-grid solar PV system for cottage hospitals. In this study, I consider the appliances needed for cottage hospital to function effectively, the end used application include (Energy saving bulb, fan, DVD player, radio, television and refrigerator). The power is derived from fifteen 100W PV solar panel unit and the total load power of these appliances is 4925Wh/day.

Keywords: PV array, Cottage Hospital, Rural Development, Storage battery, Charge Controller, inverter, Wire.

INTRODUCTION

Photovoltaic (PV) energy production is recognized as an important part of the future energy generation mix. Because it is non-polluting, free in its availability, non-hazardous, and is of high reliability. [19]. Therefore, these facts make the PV energy resource attractive for many applications, especially in rural and remote areas of most developing countries like Nigeria. Harness solar energy to power electrical appliances start by converting the energy from the sun to electricity. Photovoltaic (PV) is the direct conversion of solar energy into electricity. PV systems can be used to exploit the solar energy in almost all applications.

Electrical energy is useful in cottage hospital and industries, commercial, and residential establishments. The availability and sustainability of electrical power in any country enhance the economics of such nation. Nigeria faces serious energy crises due to decline electricity generation, from domestic power plants which are basically dilapidated, obsolete and unreliable and in appalling state of disrepair, reflecting the poor maintenance culture in the country and gross inefficiency of the public utility provider. [13]The rural areas which are generally inaccessible due to absence of good road networks, mountainous location that are far from power grid, have no access to conventional energy such as electricity. [5]. Electricity is an increasingly essential commodity in rural areas, especially health care delivery.

Rural energy is generally recognized as an important element of rural-economic development, through the demand for the services made possible through energy input such as health care delivery, portable water system and extension of the day by lighting and cooking. [7].The contribution of energy to GDP is expected to be higher when we take into account renewable energy utilization, which constitute about 90% of the energy used by the rural population.[17]As a general trend an increase in energy demand is highly correlated with socio-economic development in the rural settlement. Hence, the seminar paper is therefore an attempt to design for an off-grid solar PV system for cottage hospital.

METHODOLOGY

To design for a cottage hospital, the following electrical appliances will be considered in the design: Energy saving bulbs, fans, DVD, radio, TV and refrigerator. With their power ratings and time of operation during the day (Daily duty Cycle) hours per day, we can obtain the total energy demand for the hospital. It is situated in a rural area of Guyuk local government area of Adamawa State, Nigeria. The hospital is located on latitude of 12°10'N and longitude of 9°25'E with a population of about 800 people and total land area of 950 km². The minimum peak sun of lamza in Guyuk L.G.A is 5.5 [12].

Estimate Daily Energy Demand In Cottage Hospital.

Table 1.0

Load Description	Rated power (W)	Quantity	Daily duty cycle hrs/day	KW	KWh/day
Energy saving bulb	14	8	10	0.112	1.12
Fans	65	5	7	0.325	2.275
TV Set	80	1	6	0.080	0.480
Radio Set	75	1	4	0.075	0.30
Refrigeration	100	1	6	0.10	0.60
DVD	25	1	6	0.025	0.15
Total				0.717	4.925

ENERGY REQUIREMENT IN THE COTTAGE HOSPITAL

The cottage hospital in lamza is simple in design, just like any other cottage hospital in Nigeria and does not require large quantities of electrical energy used for lighting and other electrical appliances. The electrical load data in the cottage hospital are given in table 1.0.

TO DETERMINE THE AMOUNT OF PV NEEDED

PV panels are rated in watts. One 100-watt panel produces the same amount of power as two 50-watt panels. In lamza, 4 hours of sunlight each day, a 100-watts panel is capable of producing 4 times 100 or 400 Watt/hours of power daily. From the table 1, our daily needs are 4,925wh/day. Divide 4,925 by 400 shows that, I will need 12.3125, 100-watts panels to meet my daily needs of lamza cottage hospital. To make up for system losses, I choose 15 100-panels, also to compensate for extended periods of cloud cover.

PV ARRAY SIZING.

The size of the PV array, used in this study, can be calculated by the following equation [3].

$$PVarea = \frac{E_L}{G_{av} \times \eta_{pv} \times TCF \times \eta_{out}} \text{-----(1)}$$

Where G_{av} = average solar energy input per day.

E_L = Estimated daily load demand.

η_{pv} = PV efficiency.

TCF = Temperature correction factor.

η_{out} = Battery efficiency (η_B)* inverter efficiency (η_{in})

G_{av} = average solar energy input per day in lamza = 5.5kWh/m²/day.

Estimated daily demands = 4925wh/day.

PV efficiency = 12%.

$\eta_{out} = 0.85 \times 0.90 = 0.765$.

Temperature Correction factor: $TCF = 1 - [\gamma (T_{cell} - T_{STC})]$

But based on the manufacture specification for the selected module, $T_{cell} = 50^\circ\text{C}$

$\gamma = 0.48\%$ and $T_{STC} = 25^\circ\text{C}$

$$TCF = 1 - \left[\frac{0.48}{100} (50 - 25) \right]$$

$$TCF = 0.88$$

$$PV \text{ area} = \frac{4925}{5.5 \times 0.12 \times 0.88 \times 0.765} = 11.08\text{m}^2$$

The PV peak power, at peak solar intensity (PSI) at the earth surface is 1kw/m²[3]

PV peak power = PV area X PSI X η_{pv} = 11.08 X 1000 x 0.12 = 1.33kW

Thus, 15 modules are used to supply the required energy for the cottage hospital, the series and parallel configuration of the resulted PV array. When loads required AC power, the DC system voltage should be selected after studying available inverter characteristics. Since the total AC load is less than 5000W the system voltage selected is 24V [20]

SIZING OF BATTERY

The storage capacity of the battery can be calculated according to the relation, and there are rated in amp/hours under standard test condition of 25⁰C

$$StorageCapacity = \frac{N_c E_L}{DOD_b \eta_{out} V_{system}} \text{---(2)}$$

Where N_c = largest number of continuous cloudy days of lamza community.

DOD = Maximum' permissible depth of discharged of the battery.

V_{system} = System voltage i.e. 24V.

The largest number of continuous cloudy days N_c in lamza community is about 4 days, for a maximum depth of discharge for the battery DOD of 0.8.

$$Storagecapacity = \frac{4 \times 4925}{0.8 \times 0.765 \times 24} = 1341.23 \text{ Ah}$$

SPECIFICATION OF BATTERY TYPES TO BE USED

The battery selected is ROLLS SERIES 4000 BATTERIES, 12MD325P. The battery has a capacity of 325AH and nominal voltage is 12V. Hence, the number of batteries required is

$$N_{breq} = \frac{storagecapacity}{C_{seleted}} = \frac{1341.23}{325} = 4 \text{ batteries}$$

Number of batteries in series is given by

$$N_s = \frac{V_{SYSTEM}}{V_{BATTERY}} = \frac{24}{12} = 2 \text{ batteries}$$

Number of batteries in parallel is given by

$$N_p = \frac{N_{breq}}{N_s} = \frac{4}{2} = 2 \text{ batteries.}$$

DESIGN OF BATTERY CHARGE CONTROLLER.

The battery charge controller is required to safely charge the batteries and to maintain longer lifetime for them. It has to be capable of carrying the short circuit current of the PV array. The voltage regulator is selected to match the voltage of PV array and batteries. A good voltage regulator must have enough capacity to handle the current from PV array. [4]

The rated current of the regulator is given by,

$$I_{rated} = N_{mp} \times I_{sc} \times F_{safty} \text{---(3)}$$

$$= 5 \times 5.38 \times 1.2 = 32A$$

The voltage regulator selected is Xantrex C60 controller 60A, 12/24V, it has nominal voltage of 12/24V DC and charging load/current of 60ampers.

Number of voltage regulator required is given by

$$N_{Vreq} = \frac{I_{rated}}{I_{selected}} = \frac{32}{60} = 0.53.$$

$$N_{Vreq} = 0.53 \text{ voltageregulator.}$$

DESIGN OF THE INVERTER

The used of inverter must be able to handle the maximum expected power of AC loads. Therefore, it can be selected as 20% higher than the rated power of the total AC loads that is presented in table 1.0 Thus the rated power of the inverter becomes 985W. The specification of the required inverter will be 985W, 24V_{DC}, 220V_{AC} and 50Hz.

DETERMINATION OF THE SYSTEM CABLES SIZES:

Chosen the correct size and type of wire will enhance the maximum performance and reliability of photovoltaic system. The DC wires between the photovoltaic modules and batteries through the voltage regulator must withstand the maximum current produced by these modules; this current is given by,

$$I_{RATED} = N_{MP} \times F_{SAFTY} \times I_{SL} \text{---(4)}$$

$$= 5 \times 5.38 \times 1.2 = 32A$$

And the cross sectional area is given by

$$A = \frac{\rho L I}{V_d} \times 2$$

Where ρ = resistivity of copper wire which was taken as $1.724 \times 10^{-8} \Omega m$. In both AC and DC wiring for

standalone photovoltaic system the voltage drop is taken to exceed 4% value.[16].

DETERMINATION OF CABLES SIZE FOR PV MODULES THROUGH THE BATTERIES VOLTAGE REGULATOR.

Maximum voltage drop $V_d = \frac{4}{100} \times 24 = 0.96V$

Let the length of the cable (L) = 1m

It implies that, $A = \frac{\rho LI}{V_d} \times 2$

$$= \frac{1.724 \times 10^{-8} \times 1 \times 32}{0.96} \times 2 = 1.15mm^2$$

This implies, that any copper cable of cross sectional area of 1.15mm², 32A and resistivity of 1.724 x 10⁻⁸Ωm can be used for the wiring between PV modules and batteries through the voltage regulator.

DETERMINE CABLE SIZE BETWEEN BATTERY BANK AND INVERTER.

Let the length of the cable (l) = 3.5m, the maximum current from battery at full load supply is given by

$$I_{Max} = \frac{InverterCapacity}{\eta_{inverter} \times V_{system}} \text{-----(5)}$$

$$= \frac{0.985}{0.85 \times 24} = 48A$$

Maximum voltage drop $V_d = \frac{4}{100} \times 24 = 0.96V$

$$A = \frac{1.724 \times 10^{-8} \times 48}{0.96} \times 2 = 17mm^2$$

It implies that any copper cable of cross sectional area of 17mm², 48A and resistivity 1.724 x 10⁻⁸Ωm can be used for the wiring between the battery bank and the inverter.

DETERMINATION OF CABLE SIZE BETWEEN THE INVERTER AND THE LOAD

Let the maximum length of cable (L) =15m, the maximum current from the inverter at full load on the phase line is given by:

$$I_{Phase} = \frac{InverterCapacity}{V_{output} \times \sqrt{3}} \text{----- (6)}$$

$$= \frac{0.985}{220 \times \sqrt{3}} = 2.6 \times 10^{-5}A$$

Maximum voltage drop $V_d = \frac{4}{100} \times 220 = 8.8V$

$$A = \frac{1.724 \times 10^{-8} \times 2.6 \times 10^{-5}}{8.8} \times 2 = 1.5mm^2$$

It implies that, any copper of cross sectional area 1.5mm², 2.6x10⁻⁵A and resistivity 1.724x10⁻⁸Ωm can be used for the wiring between the inverter and load.

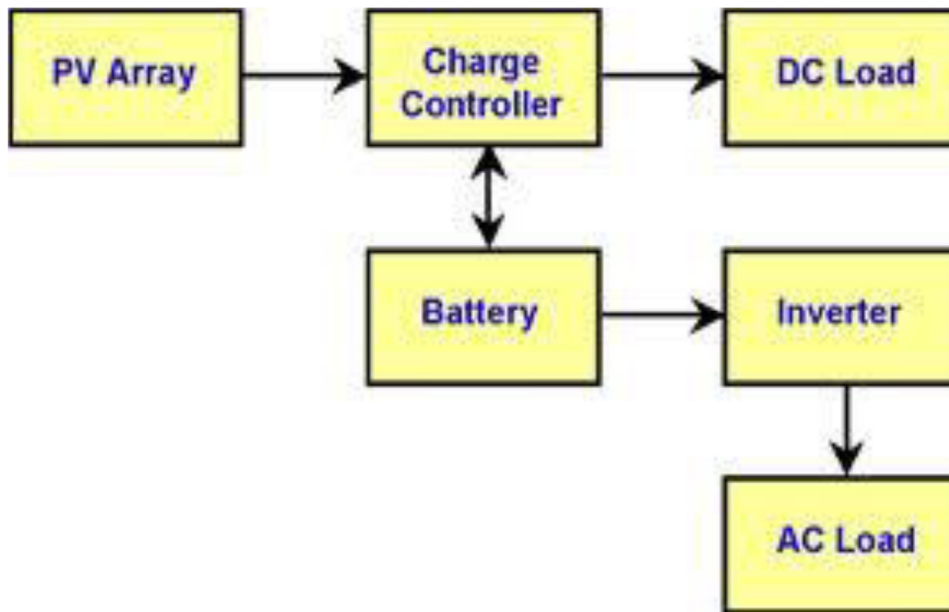

Figure 1.0 Block Diagram of the Proposed Stand-alone PV System

Results Obtained from the propose sizing of Off-grid PV system.

Table 1.1

COMPONENTS	DESCRIPTION COMPONENTS	OF	RESULTS
Load Estimation	Total estimated load		4925KWh/day
PV array	Capacity of PV array		1.4KW
	Number of modules in series		3
	Number of modules in parallel		5
	Total number of modules		15
Battery Bank	Battery bank capacity.		1341.23Ah
	Number of batteries in series.		2
	Number of batteries in parallel.		2
	Total number of batteries required.		4
Voltage Regulator	Capacity of voltage regulator		32
	Number of voltage regulator required.		0.53
Inverter	Capacity of the inverter.		0.985KW
Wire	Between PV modules and batteries through voltage regulator		1.15mm ² ,32A
	Between battery and inverter.		17mm ² , 48A
	Between inverter and load		1.5mm ² ,2.6x10 ⁻⁵ A

DISCUSSION OF RESULT

The daily electrical energy demand for cottage hospital was estimated based on the watt hours of the appliances considered in the design. The results of the estimated daily energy demand are shown in table1.1

The estimated load energy demand is 4925wh/day. The off-grid PV system was designed based on the estimated load. The results shown that cottage hospital requires ESPSA 100W, 24V PV modules to produce a PV array capable of generating 1.4KW of electrical energy for the cottage hospital. The parallel and series configuration of the resulted PV array are 15 modules required to produced current and voltage respectively. For storage of energy for use when there is demand, the cottage requires 4 of ROLL 12MD325P battery bank capacity 1341.23Ah.

To safely charge the batteries and to maintain longer life time for them. The cottage requires a voltage regulator of capacity 32A. The capacity of the inverter to convert its DC current to AC current is 0.985KW, the resistivity of the copper wire selected for the design is $1.724 \times 10^{-8}\Omega\text{m}$. The DC wires between the PV modules and batteries through the voltage regulator must withstand the maximum current produced by this module.

This current is 32A, and the optimum wire type for this current is any copper wire of cross- sectional area 1.15mm². The DC wire between the batteries and the inverter must withstand the maximum current from battery

at full load supply. This current is 48A and any copper wire of cross sectional area of 17mm^2 can be used. AC wire from the inverter to the load must withstand the maximum current produced by the inverter. This current is $2.6 \times 10^{-5}\text{A}$ and optimum wire type for this current is any copper wire of cross-sectional area 1.5mm^2

CONCLUSIONS

Electrification of cottage hospital is very important especially in the developing countries like Nigeria. The photovoltaic systems are considered as the most promising energy sources, due to their high reliability and safety. They represent, at the same time, a vital and economic alternative to the conventional energy generator. An electrification of cottage hospital in Lamza was carried out using a stand-alone PV system. This presents the complete design and cost analysis of the PV system. The result of the study indicate that electrifying a cottage hospital using PV system is beneficial and suitable for long term investments, especially if the initial prices of the PV system are less and their higher efficiencies.

REFERENCE

- [1]. Abd EL- Shafy A. Nafeh.(2009) “ *Design and Economic Analysis of a Stand- alone PV System to Electrify a Remote Area House in Egypt*”. The Open Renewable Energy Journal, Volume, 2 Pp 33-37
- [2]. Adeyemo, S.B. (1997). “*Estimation of Direct Solar Radiation Intensities*”. *Nigerian Society of Engineers (NSE) Technical Transactions*. 32(1):1-9.
- [3]. Alamsyah, T.M.I.; Sopian, K.; Shahrir, A. (2003). “ *Intechno-economics Analysis of Photovoltaic System to provide Electricity for a house hold in Malaysia*,” Proceeding of the international Symposium on Renewable Energy: Environment Protection and Energy solution for sustainable Development, Kuala Lumpur. Malaysia. Pp387-396.
- [4]. Assad Abu-sser, (2010). “*A Stand-alone Photovoltaic System, case study: A Residence in Gaza*”, Journal of applied Science in environmental sanitation. Vol. 5. Pp 81-91.
- [5]. A.S. Sambo, (2009). “*Strategic Developments in Renewable Energy*” An International Association for Energy Economics.
- [6]. Awogbemi, O. and Asaolu, J.I. (2008). “Overview of Renewable Energy Situation in Nigeria”. *Proceedings of 1st National Engineering Conference on Sustainable Energy Development in Nigeria; Challenges and Prospects*. Faculty of Engineering, University of Ado-Ekiti, Nigeria. 16 – 25.
- [7]. Balderi, I. (1995). Solar Photovoltaic for Sustainable Agriculture and Rural Development by B. van Campen, D. Guidi and G. Best 76 pp., 21 tables, 10 text boxes, 6 annexes Environment and Natural Resources Working Paper No. 2
- [8]. Caishen Wang, & M. Hashem Nehrir, (2008). “Power Management.”
- [9]. Chendo, M.A.C. 2002. “*Factors Militating Against the Growth of the Solar-PV Industry in Nigeria and their Removal*”. *Nigerian Journal of Renewable Energy*. 10 (1&2):151-158.
- [10]. Douglas, M.C. 1977. “*Energy Technology Handbook*”. McGraw Hill: New York, NY. 2, 15-25.
- [11]. European Photovoltaic Solar Energy Conference, Paris, France Vol. III” Pp 2900-2903.
- [12]. Geographical information system, Modibbo Adama University of Technology, (MAU Tech), Yola, Adamawa State. Nigeria.
- [13]. Ikeme, J. and Ebohon, J. O. (2005). Nigeria Electric Power Sector Reform: What should for the Key Objectives. *Energy Polices* 33 (2005): 1213- 1221
- [14]. Jonathan, G. (2010). “*Roadmap to Power Sector Reforms*”. Retrieved September 23, 2011.
- [15]. Mahmoud, M.M.; Ibrik, I.H. (2006). “*Techno-Economics Feasibility Of Energy Supply Of Remote Villages In Palestine By PV Systems, Diesel Generators And Electric Grid*” *Renewable Sustainable Energy Review*. Pp128-138.
- [16]. National Electrical Code (NEC, 2005)
- [17]. National Population Commission (2011). *Unpublished Population Estimate of Nigeria* (no page).
- [18]. Planning Policy Guidance 22: Annex on Photovoltaic. PO Box 276, London. Also available on www.pv-uk.org.uk
- [19]. Ramachandran, J.; Pearsall, N. M.; Putrus, G.A. (2004). “ In Reduction in Solar Radiation Fluctuation by Spatial Smoothing effect, Proceeding of the 19th European Photovoltaic Solar Energy Conference, Paris, France Vol. III” Pp2900-2903.
- [20]. Sandia, (1995). “*Stand-alone Photovoltaic System: A handbook of Recommendation Design Practices*”. Sandia National Laboratories Albuquerque New Mexico. Pp 1-B53.
- [21]. Volker, Quashing, (2005). “*Understanding renewable Energy System*”.