

Improvisation of Power Quality in Power System with the Integration of Renewable Energy using FACTS Devices

Sohail Qureshi¹ Muhammad Salman¹ Liaqat Ali² Sakhi Rehman² Muhammad Suleman²
Dr.N. Khan¹

1.Department of Electrical Engineering, COMSATS University of Science and Technology, Islamabad

2.Department of Electrical Engineering, University of Science and Technology Bannu

Abstract

The main goal in the power system is to transmit the power in a more economical way with high power quality and power factor, having a smaller possibility of system collapse or failure. Operation of power system network is going complex day by day and insecure with higher power flows without adequate control. Renewable energy when connected to the power grid can invite a lot of new problems and challenges. The output power of the wind generator is greatly affected by the variable nature of the wind speed which can cause power quality issues while integrating it to the grid network. The power quality issues include voltage fluctuation and reduced power factor. One solution is to introduce Flexible AC Transmission System (FACTS) like, Unified Power Flow Controller (UPFC), Static Synchronous Compensator (STATCOM) and Static Synchronous convertors. The main objective of power electronic convertors is to integrate renewable energy or any distributed generation to the standard of grid power factor. However, the troubles like injecting additional harmonics to the system due to the high switching frequency can cause immense power quality issues [1].

Custom power devices (CPD), which includes Shunt controllers like Static Synchronous Compensator or Static Var Compensator (STATCOM or SVC), Series Controllers like Static Synchronous Series Compensator (SSSC or TCSC), Combination of Series and Shunt Controller like Unified Power Flow Controller (UPFC) are used to interface devices between distributed generation and Series Compensator (SSSC) to improve the power factor and regulate the terminal voltage by installing it at the critical locations. MATLAB/PSAT is used to simulate the FACTS devices control scheme connected with the Wind turbine. And the effectiveness of the FACTS devices is tested by connecting the controllers at critical location of the power grid using IEEE 14 bus System.

Keywords: Unified Power Flow Controller (UPFC), Static Compensator (STATCOM), Static Synchronous Series

1. Introduction

Fossil fuels plays an important role in development of most industrial nations, but there are certain facts and realities that a society needs to understand while using it. A time will come when there will be a shortage of fossil fuels or it will become too expensive to use it realistically. Secondly the fossils fuels put some adverse effects on the atmosphere while running a steam turbine to generate a thermal power from it, which boost up the greenhouse gases like carbon dioxide, which warm up the earth temperature and create harmful effect on our climate, health and our environment. So the renewable energy is very much needed to integrate into the grid power system to minimize the issues related with global warming, resulting from generating power from conventional power plants. Therefore, at the present time an engineer focuses on to add more and more renewable energy into the grid, which will definitely reduce carbon dioxide emission and will increase energy efficiency. To integrate renewable energy into the grid power system we need power electronic consumer sides to minimize voltage/current fluctuations/disturbances and improve power factor by compensating the reactive power generated or absorbed by the load. The distributed generation like Wind or Solar are the most promising sources of generation having no threat to global warming. They have a lot of other advantages, like supporting voltage, reducing the power losses during transmission and distribution and improve the reliability of power system. The various power quality problems are serious threat to both the utility and consumers [2].

The custom power devices (CPD) can overcome the issue of power quality specially voltage fluctuation and improving power factor. This system is made up of combination of intelligent devices which will be able to detect and respond to various disturbances in the power system like voltage disturbances.

1.2 Problem Statement

Output power of the wind turbine can be greatly affected by the variable nature of the wind speed. The electricity produced from the wind generator increases or decreases depend on the speed of the wind. Thus integrating renewable energy into the grid network is quite a challenging task as it invites a lot of power quality issues like voltage fluctuations and reduced power factor. so it is vital to have an effective grid infrastructure for integrating renewable energy into the grid station.

FACTS (Flexible AC Transmission System) devices like Unified Power Flow Controller (UPFC), Static Synchronous Compensator (STATCOM) and Static Synchronous Series Compensator (SSSC) are used to

overcome these issues. They can regulate the voltage and can improve the power factor when installing it at the critical locations.

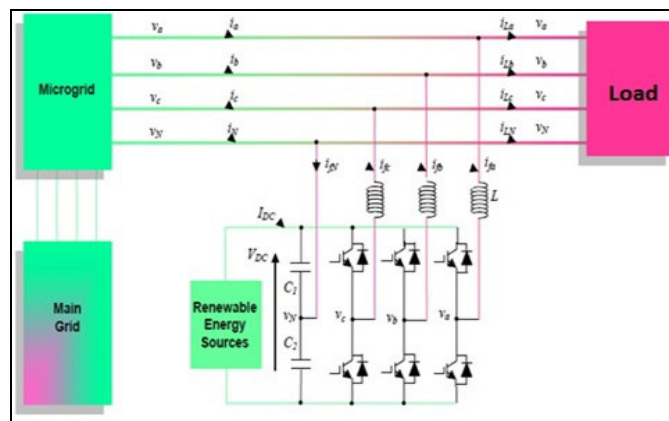

Figure 1.1: Example of control system topology [1]

1.3 Research Objectives:

Main Objective of this project is to implement the FACTS devices in transmission system and to show improved voltage stability and Power Factor.

Following are the objective of this project

- i. To implement IEEE 14 bus system Using FACTS devices.
- ii. To find out the performance of different FACTS Controllers with different combination when implementing them at a critical location in IEEE 14 bus system.
- iii. To study the Power Flow analysis of IEEE 14 bus system with and without FACTS Controller.
- iv. To show the voltage and power factor improvement in power system using FACTS devices.
- v. The main goal of this project is to improve the power factor and terminal voltage and thus efficiency of power system.

1.4 Project Significance

Operation of power system network is going complex day by day, and is insecure with higher power flows without adequate control. This all is because of the increasing power demands.

So it is very important for the power operator to have a complete control over the power transmission.

FACTS controller are used for this purpose to provide a complete control over power transmission, and thus it increases the efficiency of the power system.

This project uses three types of FACTS devices named STATCOM, SSSC and UPFC and their different combination in IEEE 14 bus system to show that how it stabilizes the terminal voltage and improve the power factor of the power system. The results obtained in this project can greatly help the power operators to achieve a maximum stability and control over power system and can greatly help the operators in future.

2. Literature Review

2.1 Introduction

This chapter discusses the introduction of FACTS controllers. The power flow analysis would also be discussed in detail.

2.2 Power Flow Study

Power flow study is an approach involving numerical analysis applied to a power system network. It uses one-line diagram and per unit system to represent voltages, angles, and power of a power system. There are number of software used for the power flow studies. Mostly it is called the base case, many software implementation conduct different types of analysis that is stability studies (transient and steady state), unit commitment and short circuit fault analysis.

Power flow or load flow studies enable us to use the system at its full capacity. This analysis gives clues and ideas that how to expand the power system in the future. The basic information the power flow study given to us is the phase angle of the voltage at each bus and the information about the power (real and reactive) flowing in the line.

The main objective behind the power flow analysis is to find out the magnitude and voltage angle for a specific load in every bus in a power system. When we know about this information we can easily find out the

reactive power in each branch as well as the reactive power of the generator.

Power flow studies are very much important analysis before connecting STATCOM, SSSC, and UPFC in the system. To evaluate the effect of FACTS devices like STATCOM, SSSC and UPFC on voltage control in the power system, power flow study is essential. Likewise, during the stage of finding out the ratings of these FACTS devices called the planning stage, the load flow study should be carried out to find the exact ratings of STATCOM, SSSC and UPFC required in the power system.

2.3 Introduction to FACTS Controllers

Flexible AC Transmission System (FACTS) is basically a power electronic based system that provides voltage controllability and can enhance energy transfer capability [3]. It has three main types, Shunt controllers, Series controller and combination of both shunt and series controller named Shunt-Series controller.

The shunt connected FACTS controller are is very helpful in improving transient stability, Power oscillation damping and above all it improves the voltage profile of a particular bus. Static Synchronous Compensator (STATCOM) and Static Var Compensator (SVC) are both Shunt connected FACTS controllers [4].

Series Connected FACTS controller is used to increase the limit of transient stability, and could improve voltage stability limit [5]. Thyristor switched series capacitor (TSSC), Thyristor Controlled Series capacitor (TCSC) and Static Synchronous Series Compensator are some of the examples of Series Connected FACTS Controller.

The third one is combination of shunt and series compensators, it provides greater flexibility and adaptability then the other two compensators. It works as a multifunctional device and provides greater control. Unified Power Flow Controller (UPFC) and Interline Power Flow Controller (IPFC) are the examples of Shunt-Series FACTS Controller [6].

2.3.1 Theory of FACTS Controllers

The shunt connected FACTS controller regulates the voltage profile when it connected in shunt with the system through a transformer. The capacitor in the shunt controller generate the reactive power while the inductor absorbs it according to need of the system. These Reactive Power generators or absorbers are used to control the reactive power of the transmission system [5]. Shunt connected FACT controller has basically three types, one is variable impedance/reactance type, second one is switching convertor type and the third one is hybrid type.

Series Connected FACTS controller has two types, the variable impedance type and switching convertor type. Its basic principle is to maximize the transmission power by minimizing the circuit impedance along the line [7, 8].

The basic function of Series and Shunt Compensators are quite similar except that the series compensator is the inverse of shunt compensator [7,8]. The third type of FACTS controller which actually mix the principle of shunt and series controller has the ability to control all the variables which degrade the power flow in the transmission line. The parameters which affect the power flow in the power system are impedance, voltage and phase angle [9].

2.3.2 Operation and Control of FACT Controller

FACTS Controller consists of Voltage Source Convertors (VSC), which has a three phase convertor bridge. One configuration which is shown in the figure 2.1 has two DC terminals having plus and negative signs three AC terminals “~” in the center of the convertor legs. We can get voltage waveform at the AC terminals by controlling the switches in the legs.

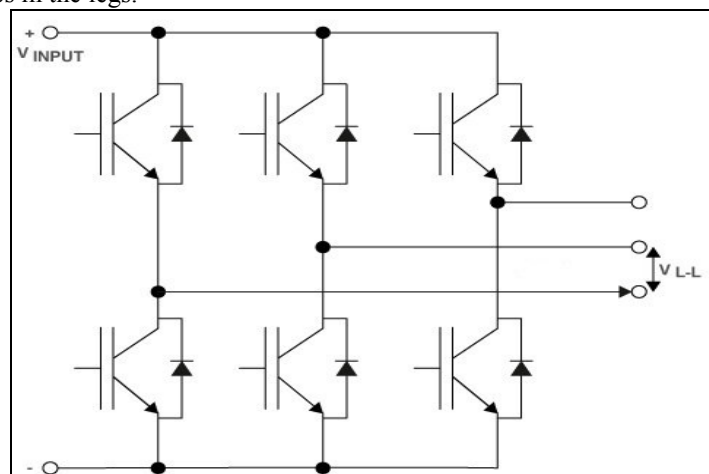

Figure 2.1: A three phase convertor bridge-the basic building block Voltage Source Convertors [7]

When Voltage Source Converter (VSC) is connected to a system, it should be operated at the frequency of that

of the line and produce a balance set of sinusoidal voltages. VSC can alter the output voltage magnitude and phase angle comparative to system voltage.

Through these two variables active and reactive power can be exchanged with the system. Symbolically it is shown in the Fig 2.2 [7].

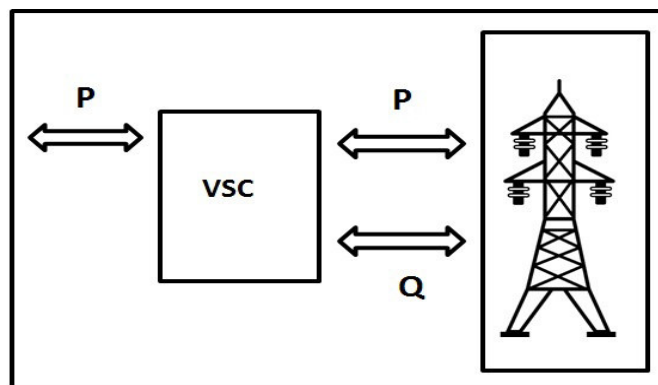

Figure 2.2: A VSC interfaced to a transmission line- P and Q exchange [7].

3. Research Material and Methods

3.1 Introduction:

This chapter discuss the methodology approach in simulating the 14-bus test system with FACTS controllers (STATCOM, SSSC and UPFC) using MATLAB Power Systems Analysis Toolbox (MATLAB/PSAT) software. This software can make analysis of load flow more accurate and easily. Before the performance and the effect of FACTS controllers in power system were evaluated, firstly the location or the placement of the FACTS controllers it selves was determined. In realizing this, an analysis named Power Flow analysis was used in order to determine the weak bus and the underutilized line, and hence determine the location of FACTS controllers in the test system.

3.2 Determination of location of FACTS Controller

The FACTS controllers were placed on the location in such a way that the capability of FACTS controllers to compensate a particular bus or line could be optimized. Therefore, it is best if the FACTS controllers would be located shunt with the weakest bus (in the case of shunt connected FACTS controllers) or series with line that have the lowest percentage of underutilize capacity or higher power losses in the selected voltage magnitude profile (in the case of series connected FACTS controllers).

Therefore, continuous power flow analysis was applied in order to determine the weakest bus and the underutilized line in the test system. The test system was analyzed without the FACTS controllers and hence the original performance of the test system was acquired. Voltage magnitude profiles for all the buses in the test network were plotted and the bus which has a worst magnitude has selected as a weak bus. On the other hand, based on the power flow report, the most underutilized line or higher power losses in the selected voltage magnitude profile were determined. The line which has the lowest power flow out of its total rating was selected as the line that needs series compensation [10].

3.3 The Performance of Series Connected FACTS Controllers

After the determination of FACTS controllers' location, the FACTS controllers were inserted in the tested network. The series FACTS controllers (SSSC) were placed in series with the selected line. To evaluate the performance of each series connected FACTS controllers, the FACTS controllers would be placed one by one. Through this way, we could compare the performance of each FACTS controller. A power flow would be used for the method in evaluating the performance of FACTS controllers. We will acquire the voltage profile for every bus and the power flow for each line.

3.4 The Performance of Shunt Connected FACTS Controller

The shunt FACTS controllers would be placed in parallel with the selected bus. There is one type of shunt connected FACTS controllers that would be used, which is STATCOM. In order to evaluate the performance of each shunt connected FACTS controllers, the FACTS controllers would be placed separately. By this approach, we could compare the performance of each FACTS controller. A power flow would be used for the method in evaluating the performance of FACTS controllers. We will acquire the voltage profile for every bus and the power flow for each line.

3.5 The Performance of Shunt-Series Connected FACTS Controllers

Based on the lowest voltage magnitude, then following by underutilized line or higher power losses in the selected voltage magnitude profile determine earlier, we place the shunt-series on the line with series part of compensator connected in series with the line and shunt part of compensator shunted with the line impedance would have to divide by two. For this combined compensator we would only consider of using only one FACTS controller, which is the UPFC. The performance analyzing method is actually similar with the previous method used for series and shunt connected FACTS controllers. With this approach, voltage profile for every buses and the power flow for each line and hence we would obtain enough data to compare with.

3.6 Summarized Flow Chart

The methodology adopted above is best explained by means of a flow chart. Figure below shows the summarized flow chart of the adopted methodology. The first thing is the selected test system, which the IEEE 14-bus test system.

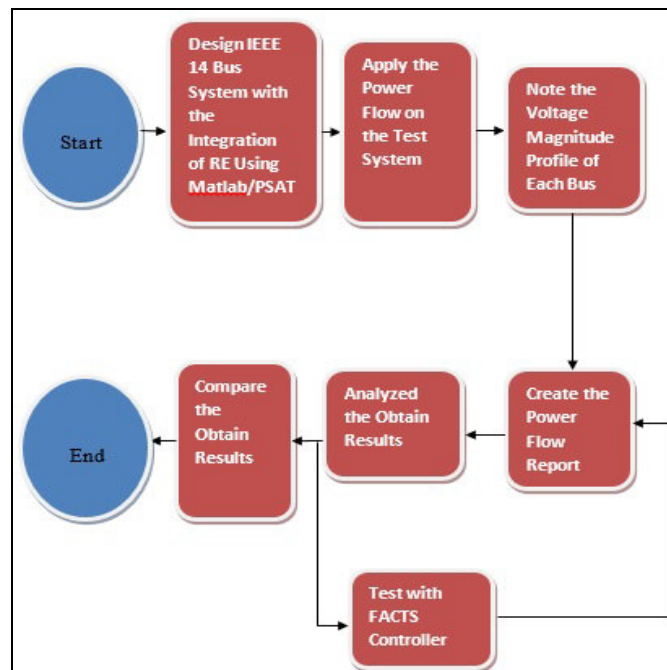

Figure 3.2: Flow chart of Research Methodology

The first thing is the test system i.e. the IEEE 14-bus test system was constructed by using the MATLAB/PSAT. The blocks that modeled the power system apparatus were used to create the test network. Then, the power flow was applied on the test system without the consideration of FACTS controllers (base case) to obtain the performance of the system without any compensator, and hence obtained the location for FACTS controllers placement. The implementation of power flow in the system yielding the voltage magnitude profile of each bus and also the power flow report that was used in the determination of location for FACTS controllers. Shunt controllers were placed at the bus which has the worst voltage profile. While series FACTS controllers on the other hand, were placed in series with the line that have the highest percentage of underutilized capacity or higher power losses in the selected voltage magnitude profile. Note that the FACTS controllers were inserted one at a time to ensure performance of each FACTS controller could be observed and analyzed.

4. Simulation and Results

4.1 Introduction

The results obtained from the simulation done in MATLAB/PSAT are presented here followed by analysis and discussion included the load flow analysis.

The simulation involves 14-bus test system without the consideration of any FACTS controllers, meaning it was just to measure the system performance without the FACTS compensation effect. Then, the system performance was measured with STATCOM, SSSC and UPFC effects taken into account.

4.2 Simulation of Base Case IEEE 14 Bus Wind Integration System without FACTS Controllers

For the Base Case, the simulation is not inclusive of any FACTS controllers, but only inclusive with Wind

Generator. This is to measure the performance of the system itself, without the consideration of any FACTS controllers.

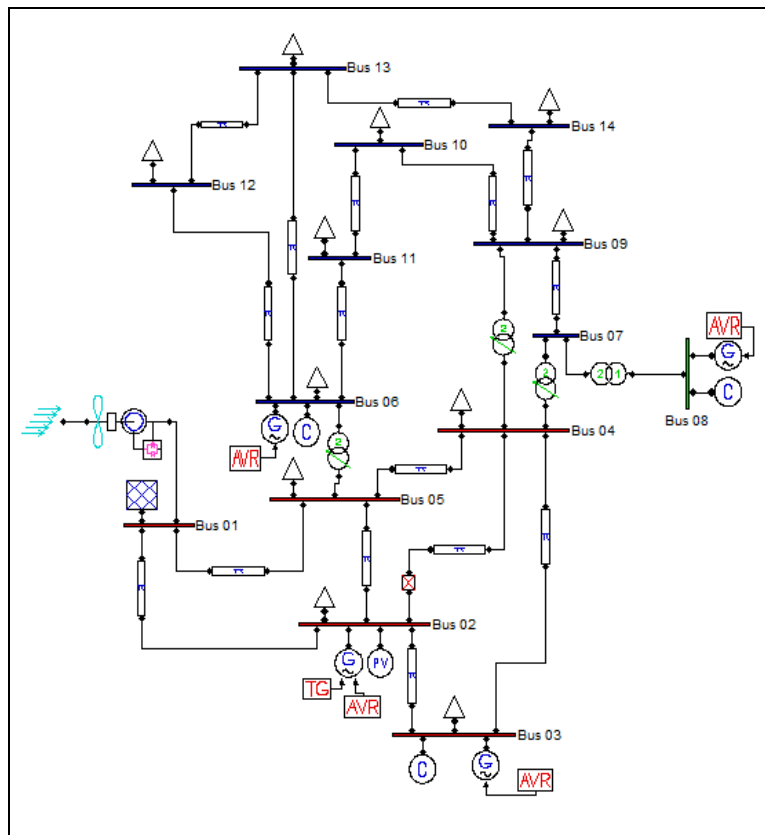

Figure 4.1: IEEE 14-Bus Test Systems Wind integration without FACTS Controller (Base Case).

The IEEE 14-Bus Test System is consisting of 14 buses and 11 loads. After ran the power flow to the system, voltage magnitude profiles were plotted and analyze to determine the weakest bus. Figure 4.2 below shows the voltage magnitude profile and figure 4.3 shows the power flow results for the test system.

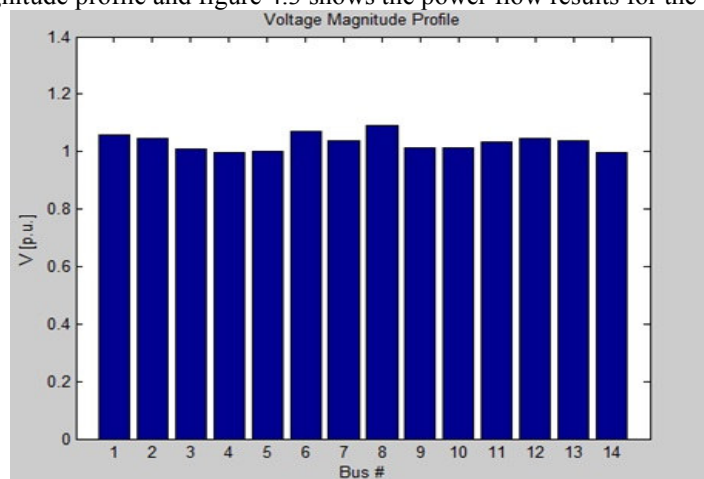

Figure 4.2: Voltage magnitude profile for base case.

Figure 4.2 shows the voltage magnitude profiles for the base case. From the graph, we need to verify which buses have the lowest voltage magnitude profile. Figure 4.3 shows more details about the power flow results for voltage magnitude profile.

Bus	Voltage [p.u.]	Phase [rad]	P Gen [p.u.]	Q Gen [p.u.]	P Load [p.u.]	Q Load [p.u.]
Bus 1	1.06	0	1.50	0.28197	0	0
Bus 2	1.045	-0.13568	1.00	0.9486	0.3038	0.001
Bus 3	1.01	-0.33212	1.00	0.59736	1.3188	0.003
Bus 4	0.99782	-0.26441	0	0	0.6692	0.01
Bus 5	1.0029	-0.22695	0	0	0.164	0.05
Bus 6	1.07	-0.36956	1.00	0.44433	0.048	0.07
Bus 7	1.036	-0.33938	0	0	0	0
Bus 8	1.09	-0.33938	1.00	0.33402	0	0
Bus 9	1.0129	-0.37908	0	0	0.0413	0.023
Bus 10	1.0122	-0.38446	0	0	0.126	0.043
Bus 11	1.0357	-0.37984	0	0	0.049	0.014
Bus 12	1.0462	-0.39059	0	0	0.0854	0.056
Bus 13	1.0366	-0.39147	0	0	0.0189	0.012
Bus 14	0.99695	-0.41056	0	0	0.2086	0.07

Figure 4.3: Power Flow Results for Base Case

In Figure 4.3, there are two buses that have voltage magnitude below 1p.u. The lowest voltage magnitude is 0.99659p.u which is bus 14, following by bus 4 with 0.99782p.u. From the figure above it is shown that bus number 14 and 4 was severely collapsed. With this, bus 14 and bus 4 was selected to be the location of FACTS controllers' placement. Three testing method will be used to analyzed the result. The method is explained as below:

- i. Testing method 1:
Install STATCOM at bus 14 and SSSC at bus 4
- ii. Testing method 2:
Install STATCOM and SSSC at bus 14.
- iii. Testing method 3
Install UPFC at bus 14.

From Bus	To Bus	Line	P Flow [p.u.]	Q Flow [p.u.]	P Loss [p.u.]	Q Loss [p.u.]
Bus 2	Bus 5	1	0.57838	0.07	0.01785	0.01885
Bus 6	Bus 12	2	0.11407	0.04591	0.00162	0.00338
Bus 12	Bus 13	3	0.02704	0.02014	0.00023	0.00021
Bus 6	Bus 13	4	0.25989	0.14446	0.00511	0.01006
Bus 6	Bus 11	5	0.1186	0.12844	0.00108	0.00531
Bus 11	Bus 10	6	-0.06706	0.09793	0.00012	0.00252
Bus 9	Bus 10	7	0.06013	-0.01389	0.00179	0.00031
Bus 9	Bus 14	8	0.12001	0.33402	0.2100	0.0451
Bus 14	Bus 13	9	-0.09038	0.00518	0.2943	0.2324
Bus 7	Bus 9	10	0.37857	-0.06862	0.016	0.01989
Bus 1	Bus 2	11	2.4172	-0.38062	0.10291	0.2557
Bus 3	Bus 2	12	-1.002	0.13952	0.04747	0.15375
Bus 3	Bus 4	13	0.31661	0.19184	0.00947	0.01071
Bus 1	Bus 5	14	1.1031	0.09865	0.05928	0.19231
Bus 5	Bus 4	15	-0.84856	-0.13731	0.00978	0.01805
Bus 2	Bus 4	16	0.7825	0.05026	0.2112	0.2001
Bus 5	Bus 6	17	0.64936	0.0724	0	0.09291
Bus 4	Bus 9	18	0.21456	0.04349	0	0.02514
Bus 4	Bus 7	19	0.37857	-0.06267	0	0.02958
Bus 8	Bus 7	20	0.25857	0.33402	0	0.01654

Figure 4.4: Line Flow Results for Base Case

From Figure 4.4, the highest power loss in bus 14 is 0.2943p.u. which is in line 9, following by bus 4 with 0.2112p.u. in line 16. These values used to determine the location of FACTS controllers for the testing in method 1. For STATCOM, it will be placed at bus 14, while SSSC will be placed at line 16.

4.3 Simulation of IEEE 14 bus wind integration system with STATCOM and SSSC testing method 1

Based on the base case result, the weakest bus in the system was at bus 4 and bus 14. Therefore, STATCOM will be placed at bus 14, while SSSC will be placed at bus 4, to simulate the effect and the performance of shunt and series FACTS controllers to the system. The one-line diagram of constructed Simulink with consideration of shunt and series FACTS controllers were shows below.

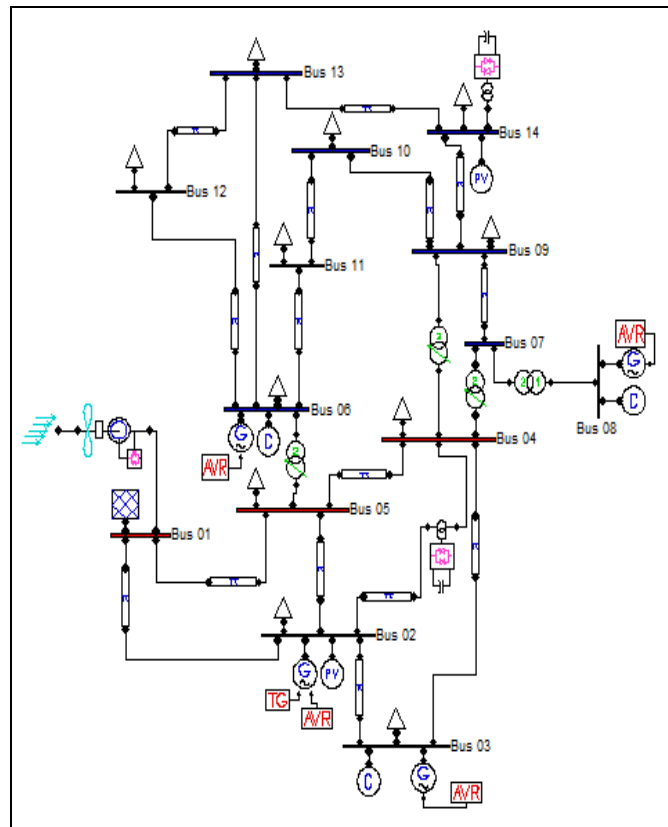
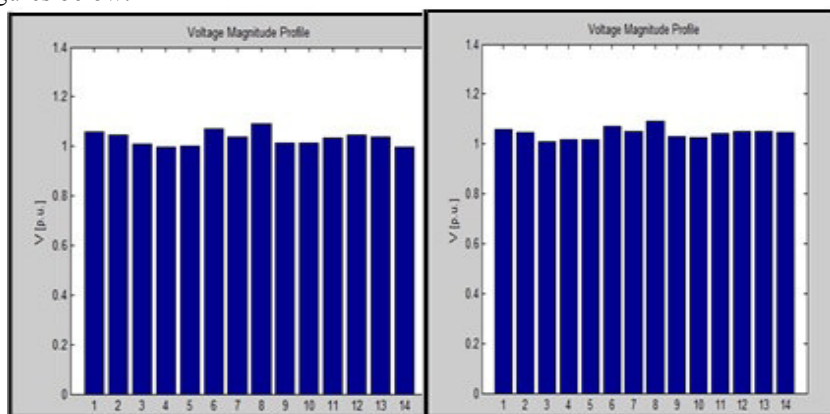

Figure 4.5: Testing method 1 with STATCOM and SSSC

Figure 4.5 shows that the FACTS controllers were shunted at bus 14 and series at bus 4. The Simulink models were simulated using the power flow method. After simulating the models, the voltage magnitude profile of the system was plotted and compared with the base case and each other. The voltage magnitude profile is shown in the figures below:



a) Without FACTS Controllers b) With FACTS Controllers

Figure 4.6: Voltage magnitude profile after installing FACTS Controllers

Figure 4.6 shows the voltage magnitude profiles for the wind integration system with and without STATCOM and SSSC using testing method 1. From the graph, we can see the voltage magnitude was improved after injected with FACTS controllers. Figure 4.8 shows more details about the power flow results for voltage magnitude profile.

Bus	Voltage [p.u.]	Phase [rad.]	P Gen [p.u.]	Q Gen [p.u.]	P Load [p.u.]	Q Load [p.u.]
Bus 1	1.06	0	1.50	0.2928	0	0
Bus 2	1.045	-0.13568	1.4	0.96418	0.3038	0.1778
Bus 3	1.01	-0.33212	1.00	0.59736	1.3188	0.266
Bus 4	1.0185	-0.26441	0	0	0.6692	0.056
Bus 5	1.0029	-0.22695	0	0	0.164	0.0224
Bus 6	1.07	-0.36956	1.00	0.44433	0.1568	0.105
Bus 7	1.036	-0.33938	0	0	0	0
Bus 8	1.09	-0.37908	1.00	0.33402	0	0
Bus 9	1.0129	-0.37908	0	0	0.413	0.2324
Bus 10	1.0122	-0.38446	0	0	0.126	0.0812
Bus 11	1.0357	-0.37984	0	0	0.049	0.0252
Bus 12	1.0462	-0.39059	0	0	0.0854	0.0224
Bus 13	1.0366	-0.39147	0	0	0.189	0.0812
Bus 14	1.045	-0.41056	0.4	0.27	0.2086	0.07

Figure 4.7: Power Flow Results Using testing method 1

From the Figure 4.7: the power flow results for the wind integration system with STATCOM and SSSC using testing method 1 are given. The voltage magnitude for bus 14 increased from 0.99782p.u to 1.045p.u and bus 4 increased from 0.99782p.u to 1.0185p.u.

From Bus	To Bus	Line	P Flow [p.u.]	Q Flow [p.u.]	P Loss [p.u.]	Q Loss [p.u.]
Bus 2	Bus 5	1	0.41426	0.01448	0.00901	-0.00872
Bus 6	Bus 12	2	0.07848	0.0438	0.00087	0.0018
Bus 12	Bus 13	3	0.00779	0.0196	9e-04	8e-04
Bus 6	Bus 13	4	0.12422	0.11355	0.00164	8e-05
Bus 6	Bus 11	5	0.09564	0.10411	0.00166	0.00347
Bus 11	Bus 10	6	-0.04498	0.07544	0.00058	0.00136
Bus 9	Bus 10	7	0.08181	0.00767	0.0002	0.00054
Bus 9	Bus 14	8	-0.1143	-0.00979	0.00158	0.00337
Bus 14	Bus 13	9	-0.07552	-0.04615	0.19243	0.1652
Bus 7	Bus 9	10	0.24239	0.20238	0.016	0.00997
Bus 1	Bus 2	11	2.1165	-0.32295	0.07874	0.18193
Bus 3	Bus 2	12	-0.90137	0.09463	0.03806	0.11407
Bus 3	Bus 4	13	0.41743	0.11423	0.01259	-0.00346
Bus 1	Bus 5	14	0.90198	0.03015	0.03928	0.10897
Bus 5	Bus 4	15	-0.70641	-0.20233	0.00691	0.0085
Bus 2	Bus 4	16	5.3869	1.7094	0.1990	0.1552
Bus 5	Bus 6	17	0.45514	0.12431	0	0.04692
Bus 4	Bus 9	18	0.13812	0.04867	0	0.0108
Bus 4	Bus 7	19	0.24239	-0.03137	0	0.01152
Bus 8	Bus 7	20	0.25857	0.2549	0	0.00963

Figure 4.8: Line Flow Results for Testing Method 1

Figure 4.8 shows the power losses at line 9 are decreased from 0.2943p.u. to 0.19243p.u. while power losses at line 16 are decreased from 0.2112 p.u. to 0.1990p.u. These values shows that the FACTS controllers have improve the power flow in the 14-bus test system.

4.4 Simulation of IEEE 14 bus Wind Integration System with STATCOM and SSSC Using Testing Method 2.

Based on the base case result, the weakest bus in the system was at bus 14. Therefore, STATCOM and SSSC will be placed at bus 14, to simulate the effect and the performance of FACTS controllers to the system. The one-line diagram of constructed Simulink with consideration of shunt and series FACTS controllers were shows below.

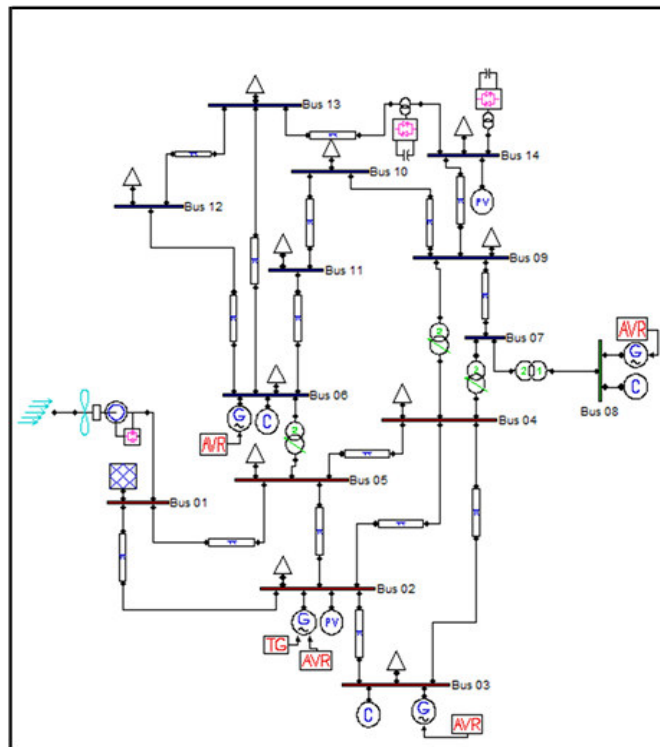
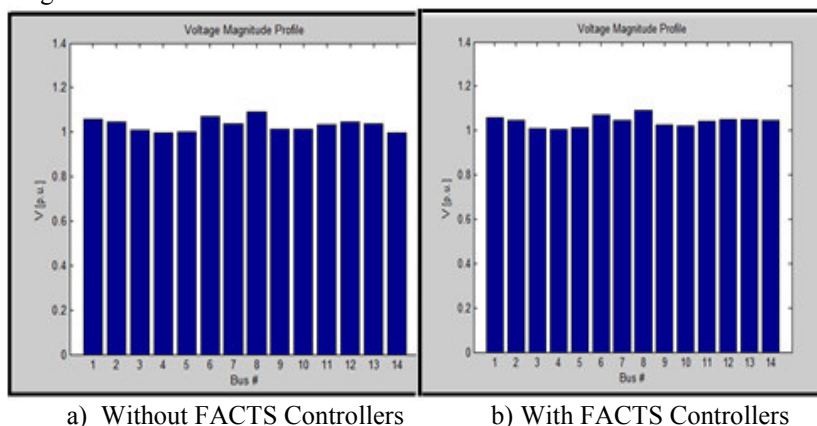

Figure 4.9: Testing method 2, with STATCOM and SSSC at bus 14

From the figure 4.9 above, it could be shown that the FACTS controllers were shunted and series at bus 14. The Simulink models were simulated using the power flow method. After simulating the models, the voltage magnitude profile of the system was plotted and compared with the base case and each other. The voltage profile was shown in the figure below.



a) Without FACTS Controllers b) With FACTS Controllers

Figure 4.10: Voltage magnitude profile after installing FACTS Controllers.

Figure 4.10 shows the voltage magnitude profiles for the wind integration system with and without STATCOM and SSSC using testing method 2. From the graph, we can see the voltage magnitude profile was improved after injected with FACTS controllers. Figure 4.10 shows more details about the power flow results for voltage magnitude profile.

Bus	Voltage [p.u.]	Phase [rad]	P Gen [p.u.]	Q Gen [p.u.]	P Load [p.u.]	Q Load [p.u.]
Bus 1	1.06	0	1.500	0.25775	0	0
Bus 2	1.045	-0.13568	1.4	0.76476	0.3038	0.1778
Bus 3	1.01	-0.33212	1.00	0.54577	1.3188	0.266
Bus 4	1.0065	-0.26441	0	0	0.6692	0.056
Bus 5	1.0029	-0.22695	0	0	0.164	0.0224
Bus 6	1.07	-0.36956	1.00	0.30522	0.1568	0.105
Bus 7	1.036	-0.33938	0	0	0	0
Bus 8	1.09	-0.33938	1.00	0.28489	0	0
Bus 9	1.0129	-0.37908	0	0	0.413	0.2324
Bus 10	1.0122	-0.38446	0	0	0.126	0.0812
Bus 11	1.0357	-0.37984	0	0	0.049	0.0252
Bus 12	1.0462	-0.39059	0	0	0.0854	0.0224
Bus 13	1.0366	-0.3914	0	0	0.189	0.0812
Bus 14	1.045	-0.41056	0.4	0.07906	0.2086	0.07

Figure 4.10: Power Flow Results Using Testing Method 2

Figure 4.10 shows the power flow results for the wind integration system with STATCOM and SSSC using testing method 2. We can see the voltage magnitude for bus 14 increased from 0.99695p.u from base case to 1.045p.u.

From Bus	To Bus	Line	P Flow [p.u.]	Q Flow [p.u.]	P Loss [p.u.]	Q Loss [p.u.]
Bus 2	Bus 5	1	0.47383	0.04469	0.01192	0.00043
Bus 6	Bus 12	2	0.07848	0.03958	0.00077	0.0016
Bus 12	Bus 13	3	0.01128	0.01558	7e-04	7e-04
Bus 6	Bus 13	4	0.11346	0.09506	0.00127	0.00249
Bus 6	Bus 11	5	0.10769	0.10807	0.00193	0.00404
Bus 11	Bus 10	6	-0.05676	0.07883	0.00072	0.00167
Bus 9	Bus 10	7	0.07011	0.00444	0.00015	0.0004
Bus 9	Bus 14	8	0.10187	-0.03101	0.00137	0.00292
Bus 14	Bus 13	9	3.2714	1.7448	0.22513	0.1862
Bus 7	Bus 9	10	0.24303	0.19329	0.0053	0.00973
Bus 1	Bus 2	11	2.1088	-0.3214	0.07817	0.13073
Bus 3	Bus 2	12	-0.94521	0.11383	0.04201	0.11407
Bus 3	Bus 4	13	0.37359	0.16593	0.01138	-0.00612
Bus 1	Bus 5	14	0.94237	0.06365	0.0431	0.12513
Bus 5	Bus 4	15	-0.80194	-0.12765	0.00858	0.01404
Bus 2	Bus 4	16	0.66574	0.02381	0.2112	0.2001
Bus 5	Bus 6	17	0.45284	0.08803	0	0.04554
Bus 4	Bus 9	18	0.13821	0.03268	0	0.0104
Bus 4	Bus 7	19	0.24303	-0.06702	0	0.01255
Bus 8	Bus 7	20	0.25857	0.28489	0	0.01203

Figure 4.11: Line Flow Results Using Testing Method 2

Figure 4.11 shows the power losses at line 9 are decreased from 0.2943p.u. from base case to 0.22513p.u. These values shows that the FACTS controllers have improve the power flow in the 14-bus test system.

4.5 Simulation of IEEE 14 bus Wind Integration System with UPFC Using Testing Method 3

Based on the base case result, the weakest bus in the system was at bus 14. Therefore, UPFC will be placed

at bus 14, to simulate the effect and the performance of FACTS controllers to the system. The one-line diagram of constructed Simulink with consideration of shunt-series FACTS controllers were shows below.

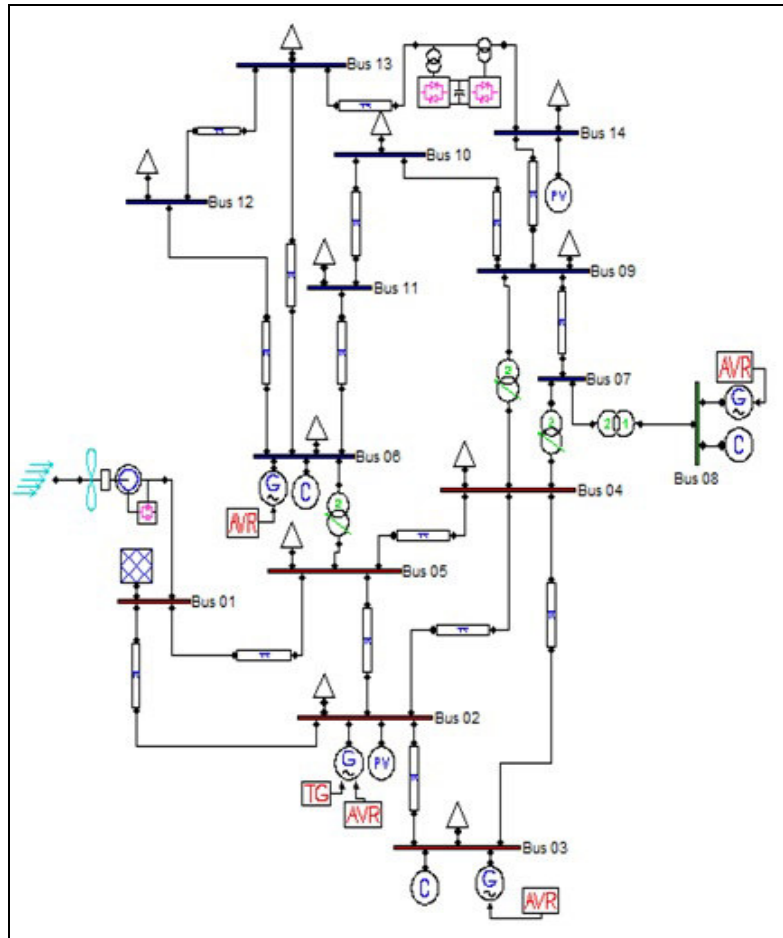
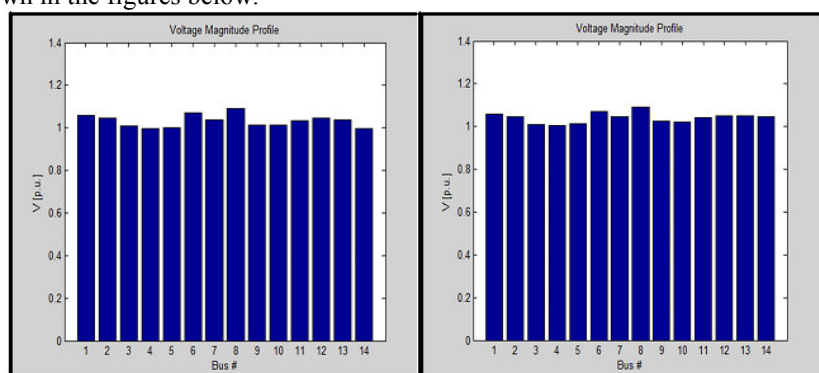

Figure 4.12: The testing method 3 with UPFC at bus 14.

From the figure 4.12 above, it could be shown that the FACTS controllers were shunted-series at bus 14. The Simulink models were simulated using the power flow method. After simulating the models, the voltage magnitude profile of the system were plotted and compared with the base case and each other. The voltage profiles were shown in the figures below.



a) Without FACTS Controllers b) With FACTS Controllers

Figure 4.13: Voltage magnitude profile after installing FACTS Controllers

Figure 4.13 shows the voltage magnitude profiles for the wind integration system with and without UPFC using testing method 3. Graph shows that the voltage magnitude was improved after installing FACTS Controllers. Figure 4.14 shows more details about the power flow results for voltage magnitude profile.

Bus	Voltage [p.u.]	Phase [rad]	P Gen [p.u.]	Q Gen [p.u.]	P Load [p.u.]	Q Load [p.u.]
Bus 1	1.06	0	1.500	-0.25775	0	0
Bus 2	1.045	-0.13568	1.00	0.76476	0.3038	0.1778
Bus 3	1.01	-0.33212	1.00	0.54577	1.3188	0.266
Bus 4	1.0065	-0.26441	0	0	0.6692	0.056
Bus 5	1.0029	-0.22695	0	0	0.164	0.0224
Bus 6	1.07	-0.36956	1.00	0.30522	0.1568	0.105
Bus 7	1.036	-0.33938	0	0	0	0
Bus 8	1.09	-0.33938	1.00	0.28489	0	0
Bus 9	1.0129	-0.37908	0	0	0.413	0.2324
Bus 10	1.0122	-0.38446	0	0	0.126	0.0812
Bus 11	1.0357	-0.37984	0	0	0.049	0.0252
Bus 12	1.0462	-0.39059	0	0	0.0854	0.0224
Bus 13	1.0366	-0.39147	0	0	0.189	0.0812
Bus 14	1.045	-0.41056	0.4	0.07906	0.2086	0.07

Figure 4.14: Power Flow Results Using Testing Method 3

Figure 4.14 shows the power flow results for the wind integration system with UPFC using testing method 2. We can see the voltage magnitude for bus 14 increased from 0.99695p.u to 1.045p.u.

From Bus	To Bus	Line	P Flow [p.u.]	Q Flow [p.u.]	P Loss [p.u.]	Q Loss [p.u.]
Bus 2	Bus 5	1	0.47383	0.04469	0.01192	0.00043
Bus 6	Bus 12	2	0.07848	0.03958	0.00077	0.0016
Bus 12	Bus 13	3	0.01128	0.01558	7e-04	7e-04
Bus 6	Bus 13	4	0.11346	0.09506	0.00127	0.00249
Bus 6	Bus 11	5	0.10769	0.10807	0.00193	0.00404
Bus 11	Bus 10	6	-0.05676	0.07883	0.00072	0.00167
Bus 9	Bus 10	7	0.07011	0.00444	0.00015	0.0004
Bus 9	Bus 14	8	-0.10187	-0.03101	0.00137	0.00292
Bus 14	Bus 13	9	2.5225	-0.71161	0.20513	0.1352
Bus 7	Bus 9	10	-0.24303	0.19329	0.19329	0.00973
Bus 1	Bus 2	11	2.1088	-0.3214	0.07817	0.13073
Bus 3	Bus 2	12	-0.94521	0.11383	0.04201	0.11407
Bus 3	Bus 4	13	0.37359	0.16593	0.01138	-0.00612
Bus 1	Bus 5	14	0.94237	0.06365	0.0431	0.12513
Bus 5	Bus 4	15	-0.80194	-0.12765	0.00858	0.01404
Bus 2	Bus 4	16	0.66574	0.02381	0.2112	0.2001
Bus 5	Bus 6	17	0.45284	0.08803	0	0.04554
Bus 4	Bus 9	18	0.13821	0.03268	0	0.0104
Bus 4	Bus 7	19	0.24303	-0.06702	0	0.01255
Bus 8	Bus 7	20	0.25857	0.28489	0	0.01203

Figure 4.15: Line Flow Results Using Testing Method 3

Figure 4.15 shows the power losses at line 9 are decreased from 0.2943p.u. to 0.20513p.u. This value shows that the FACTS Controllers had improved the power flow in the 14-bus test system.

4.6 Summarization of the results

Table 4.1: Simulation Results for the testing

Method	Bus/Line			Power Factor	P Losses [p.u]
	SSSC	STATCOM	UPFC		
0	-	-	-	0.89	0.2943
1	2-4	14	-	0.91	0.19243
2	14-13	14	-	0.91	0.22513
3	-	-	14-13	0.91	0.20513

From the Table 4.1, the simulation results for the testing method 0 mean the testing for based case without FACTS controllers. The power factor for base case is 0.89, while the real losses are 0.2943p.u. For the method 1, SSSC is applied in line 2-4 and STATCOM is applied at bus 14. The power factor for method 1 is 0.91 and the real power losses decreased to 0.19243p.u. For method 2, SSSC is applied in line 14-13, while STATCOM is applied at bus 14. The power factor for method 2 is almost same with the power factor in method 1, which is 0.91. But the real power losses for method 2 are slightly higher than method 1, which is 0.22513p.u. That was makes the method 2 transferred less power than method 1. For method 3, we use UPFC as FACTS controllers. In this method again power factor is almost the same, losses will be slightly less than method 2 but a bit higher than method 1. From the results, we can conclude that the best method is method 1, which is obtains 0.91 for power factor and 0.19243p.u for real power losses. This means method 1 will transferred more power to the system than the other two methods.

5. Conclusion

5.1 Research Conclusion:

The purpose of this project is to identify the effect of hybrid FACTS controllers in term of power factor and power quality improvement when implement it in power system. Three methods are used and several simulations have been run in MATLAB/PSAT to test the 14-bus system with and without FACTS controllers. The performance of each FACTS controllers used have been evaluated. Therefore, it could be concluded that specific type of FACTS controllers would improves some of the power system parameters, by placing it at the critical locations. This project has successfully tested at the 14-bus test system and optimal location of STATCOM, SSSC and UPFC also had been determined refer to the voltage magnitude and power losses. The performance of the power system with different location of the device had been analyzed and found that SSSC and STATCOM give better results when installing them at two different locations having low voltage magnitudes than UPFC. Because UPFC can be installed just at single location of low voltages, but STATCOM and SSSC can be installed at two different location having low voltages magnitudes.

5.2 Future Recommendation

There are few recommendations for future work for improving this project. These are follow:

- Test the system using others FACTS controllers such as SVC and TCSC because different device can show different effect for power factor improvement.
- Test the system using other simulation software like PSCAD, POWERWORLD, and other software because different software using different coding and different method.
- Test the FACTS controllers on a very large network, to view its capability handling complex network. Find and develop new method to improve power system delivery quality for reduce losses and improve power factor, voltage stability and other.

References

- [1] S. K. Khadem, M. Basu and M.F. Conlon, "Power quality in grid connected renewable energy systems," *Role of Custom Power Devices. School of Electrical Engineering Systems. Dublin Institute of Technology. 2010.*
- [2] I.El-Samahy, El-Saadany, "The effect of DG on power quality in a deregulated environment," *IEEE Power Engineering Society General Meeting 2005. 2969-2976.*
- [3] F. Wu, X. Zhang and Ping Ju, "Impact of wind turbines on power system stability," *Bulk Power System Dynamics and Control - VII. Revitalizing Operational Reliability, 2007 iREP Symposium, Charleston, SC, 2007, pp. 1-7.* doi: 10.1109/IREP.2007.4410535
- [5] G.Fandi, Z. Muller, L. Straka and J. Svec, "FACTS devices influence on power losses in transmission systems," *Electric Power Engineering (EPE), Proceedings of the 2014 15th International Scientific Conference on, Brno, 2014, pp. 29-33.* doi: 10.1109/EPE.2014.6839431
- [5] B.Gopinath and C.Keerthana, "Simultaneous tuning of power system damping controllers using Pi controller," *International Journal of Communications and Engineering. Volume 04 – No.4. Issue: 04 March 2012. 24-30.*
- [6] L. Gyugyi, "The Unified Power Flow Controller a new approach to power transmission controller," *IEEE Transaction of Power Delivery. Volume 10, No. 2, April 1995, 1085-1097.*
- [7] N.G. Hingorani, L. Gyugyi, "Understanding FACTS, concepts and technology of Flexible AC Transmission Systems," *IEEE Press 2000.*
- [8] S. Amara and H. Abdallah Hsan, "Power system stability improvement by FACTS devices: A comparison between STATCOM, SSSC and UPFC," *2012 First International Conference on Renewable Energies and Vehicular Technology, Hammamet, 2012, pp. 360-365.* doi: 10.1109/REVET. 2012.6195297
- [9] A. Kumar Sahoo, "An Improved UPFC control to enhance power system stability," *Modern Applied Science. Vol. 4, No. 6; June 2010. 37-48*
- [10] L.A.S. Pilotto, W.F. Long and A. Edris. "Determination of needed FACTS controllers that increase asset utilization of power systems," *IEEE Transactions on Power Delivery, Vol. 12, No 1, January 1997. 364-371.*