

# Examining Daylighting and Shading Devices Performance in High Temperature Conditions

Rawan Abu-Alatta, (Corresponding author)  
Collage of engineering, Albalqa' Applied University

Rasha Baan, Rawan Kanan

## Abstract

At recent days, many architects tend to design buildings' envelope with highly void ratio to insure view out and allow the maximum access to daylight. Using large glazed facades in sub-tropical climates, like Jordan is considered as a challenge due to the glare and overheating that leaves behind. Daylight and shading devices were developed to improve occupants' comfort inside buildings in such climates at the same time saves energy. Solving the over glare and heat caused by direct sunlight is one of the most important reasons why they were used. They can block up to 90 percent of this heat. The current research examined the thermal effect of three daylight and shading devices in one of Jordan University of Science and Technology (JUST) typical corridors. The research used real experiments to study what was mentioned by using light shelf (louvers), egg-crate and double facades. They were installed in one of identical physical models in real sky to compare air temperature inside with non-treated one. The results showed that double facade "textured glass" performed better than the other two devices to control the unprofitable heat that enters the building.

**Keywords:** Daylight and shading devices, heat gain. light shelf, egg-crate and double facades.

## 1. Introduction

Recently, many architects tend to use more glass area in buildings facades to allow more sunlight enter the buildings. Insuring sunlight to inter inside buildings is an important need because of its benefits on providing healthy environment and to reduce the amount of electrical lighting required. On the other side, increasing the amount of daylight introduces too much glare and heat at certain times of the day. Therefore, it is necessary to control solar radiation and decrease overheat gain inside them. To avoid negative impact of daylight, external and internal devices were designed to prevent the access of sun rays to internal spaces when the external air temperature is more than the average which is suitable for human comfort. Innovative and efficient devices were used to use to provide occupants a more comfortable environment with a sufficient daylight factor inside the buildings. Daylighting and shading devices are to allow minimum solar radiation and as well as sufficient day lighting into buildings and provide thermal comfort to the inhabitants. The perfect solar device should provide the required protection from direct sunlight without blocking vision or minimizing the effectiveness of natural ventilation. Types and design of daylight and shading devices specify the level of thermal control (Boake, Harrison et al., 2003, Kirankumar, Saboor et al., 2018).

Generally, tropical and subtropical areas temperature is uncomfortably high during daytime, especially during the warmer seasons and in low altitude locations. In such regions (hot and dry air conditions areas), the solar radiation is severe and direct. Architects who design in tropical and subtropical climate conditions try to provide comfortable environment for living with a minimum consumption of artificial energy. These two subjects helps to reduce environmental negative effects and decrease running costs (SKAT, 1993). Daylight in such regions are sufficient to provide spaces with required illumination without the need for artificial lighting. On the other hand, over heat gain and direct glare appear to formulate problems that need to be treated. Then, daylighting systems in the both tropical and sup-tropical regions are required to be as a solution for these negative impacts (Ho, Chiang et al., 2008).

Jordan is one of these countries which has a hot, dry climate characterized by long, hot, dry summers and short, cool winters, figure (1). The climate is influenced by Jordan's location between the subtropical aridity of the Arabian desert areas and the subtropical humidity of the eastern Mediterranean area (Weatheronline.co.uk). Therefore, what was mentioned above could be applied to Jordanian areas buildings which could benefit from sunlight illumination while using adequate devices and systems to avoid its associated problems.

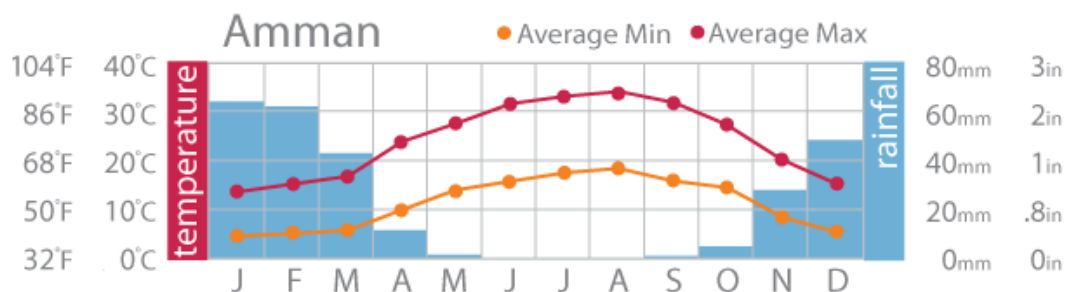

Figure 1 : Climate in Amman, Jordan (Source: <https://www.classicwadirumtours.com/all-about-jordan/jordan-weather-climate/>).

Various studies were previously conducted on daylighting and shading devices. Some previous research concentrated on the role of using such systems on decreasing buildings' indoor rooms temperatures. Another studies focused on the relationship between using shading systems with optimizing energy consumption, using simulations. While other researchers conducted comparative research of thermal performances of daylighting and shading devices of buildings (Kim, Shin et al., 2017).

It must be noted that most of the previous studies are applied on rooms or large spaces such as halls. While there are very few researches put corridors under study, although they are important spatial elements that affects other related spaces. In addition of being one of the places that are exposed to large amounts of sunlight during the day, especially in the summer. So, this study aims at analyzing and comparing the thermal effect of three types of daylighting devices in one of typical corridors in JUST. Light shelves, egg-crate and double facade which are well-known in their efficient performance in controlling the amount of light entering the space in tropical and subtropical areas.

## 2. Daylighting Devices Systems

Openings in architectural facades usually contain elements designed to various functions. Their usage may be for ventilation, provision of daylight, preventing direct sun glare, insuring privacy and security. In addition to use them as protection devices from all pollution sources. Daylighting and shading devices are an example of these elements, they are mainly expected to prevent glare and heat gain at the same time allow view out (Wulfinghoff, 1999).

### 2.1 Light shelf :

light shelf is a simple horizontal or a tilted elements that is installed inside /and or outside the glazed façade, as shown in figure (2). Light shelves are considered the best solution to reduce the glare resulted from the penetration of daylighting inside the building. When daylight enters any interior space turns into heat energy. This increases the cooling load in warm weather and decreases the heating load in cold weather. They reflect direct sunlight and also alter its direction from windows so that it comes from a more overhead direction, enhancing the quality of illumination which increases physical comfort within a certain space. The light shelves' function are simply to reflect direct sunlight from the windows which face daylight between southeast and southwest directions. They may be built of many materials, such as wood, metal, glass, plastic, or fabric (Wulfinghoff, 1999, Almssad and Almusaed, 2014).



Figure 2: Section for horizontal and tilted light shelf; light shelves installed inside and outside the windows (Source: (Wulfinghoff, 1999)).

There are no standard dimensions in manufacturing and installing light shelves, they should just suit the proportion to the window wide and height below. The light shelf should be as wide as the window, and the depth of the light shelf depends on the elevation of the sun. On the other hand, it must be installed above the height of a tall person to do not obstacle the circulation and to do not reflect glare into people's eye. The shape of light shelf as the name implies, it looks like a blade or a roof overhang. It must be much wider than the windows. There is another light shelf configuration to consider. It consists of louvers or outrigger system, as shown in figure (3) (Wulfinghoff, 1999).

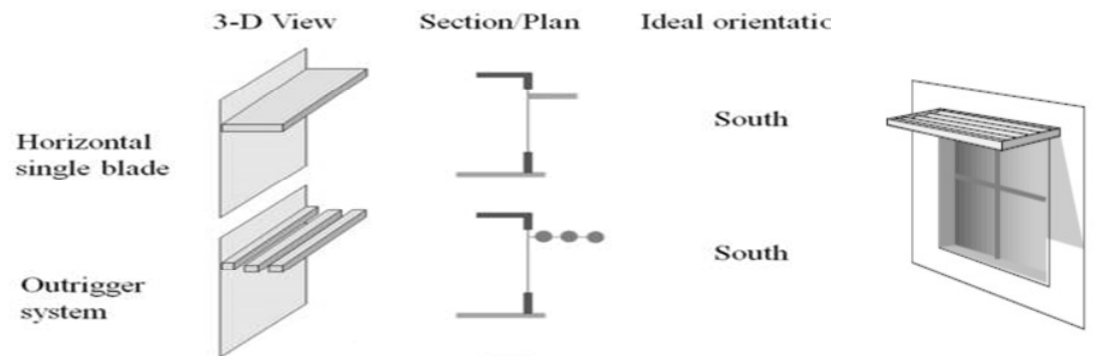

<https://www.scribdshare.net/RenuSinghParmar/solar-control-shading-devices> ).

Therefore, in the present paper, research results are presented for horizontal fixed light shelf louvers in place of solid overhang to diffuse more light while still shading.

### 2.2 Egg-crate:

The egg-crate shading device is a combination of vertical and horizontal elements. It may be used where only horizontal or vertical protection alone would not provide shade. They are usually in the form of grid blocks or decorative screens, as shown in the following figure. They are used in the south-eastern and south-west façades, and are designed based on the value of horizontal and vertical shadow angles. Their performances are also determined by both the horizontal and vertical shadow angles (Ogunsote, 1993).



Figure 4: Explanation of egg-crate shading device form, (Source: [http://www.artefacts.co.za/main/Buildings/image\\_slide.php?type=2&bldgid=9197&rank=8](http://www.artefacts.co.za/main/Buildings/image_slide.php?type=2&bldgid=9197&rank=8), <http://www.nationalmetals.com/specialty-products.php>).

It is more commonly used in hot climate regions because of their high shading efficiency. The horizontal elements control ground glare from reflected solar rays. It may be required on east to southeast and on west to southwest oriented surfaces. It could be made of precast concrete or brick elements, timber or other similar material. figure (5).

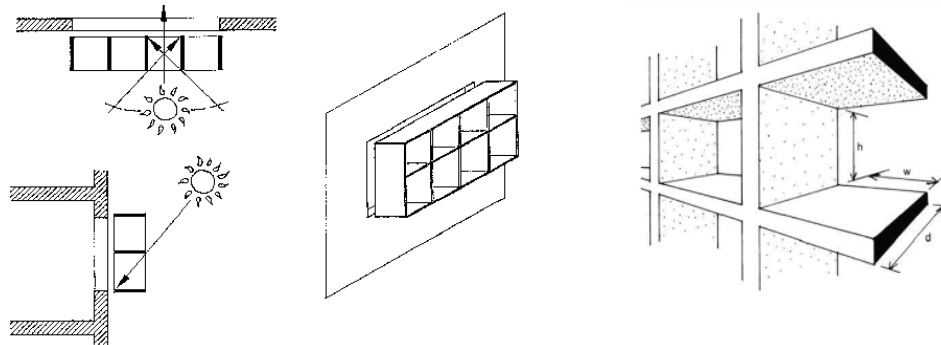

Figure 5: Egg-crate shading device details (Source: <http://slideplayer.com/slide/7083910/> ).

### 2.3 Double facades:

The Double Skin Façade shown in figure (6) is based on the concept of external walls which react with changeable climatic conditions. It can serve as a sun-protector, a natural ventilation supplier and as a thermal insulator device. Recently, double skin façade systems are employed increasingly in transparent and glass architecture, and furthermore they turned to a substantial demand to achieve an environmental responsible design (Boake, Harrison et al., 2003).

Double-skin facade is an envelope in which duplicate layers of glass are separated by a significant amount of air space. These two layers of single glazing space 25 to 90 cm apart. The air buffer zone which separated them insulates extreme temperature, winds and sound (Boake, Harrison et al., 2003).



Figure 6: Double Skin Façade (Source: <http://italwindows.com/products/double-skin-facades/>,  
<http://www.alumgostar.com/index.php/en/products-2/facade/double-skin-facade.html>).

Double skin façade combines the passive techniques of natural ventilation, daylighting and heat gain which guarantee energy efficiency as shown in the following figure (Boake, Harrison et al., 2003).

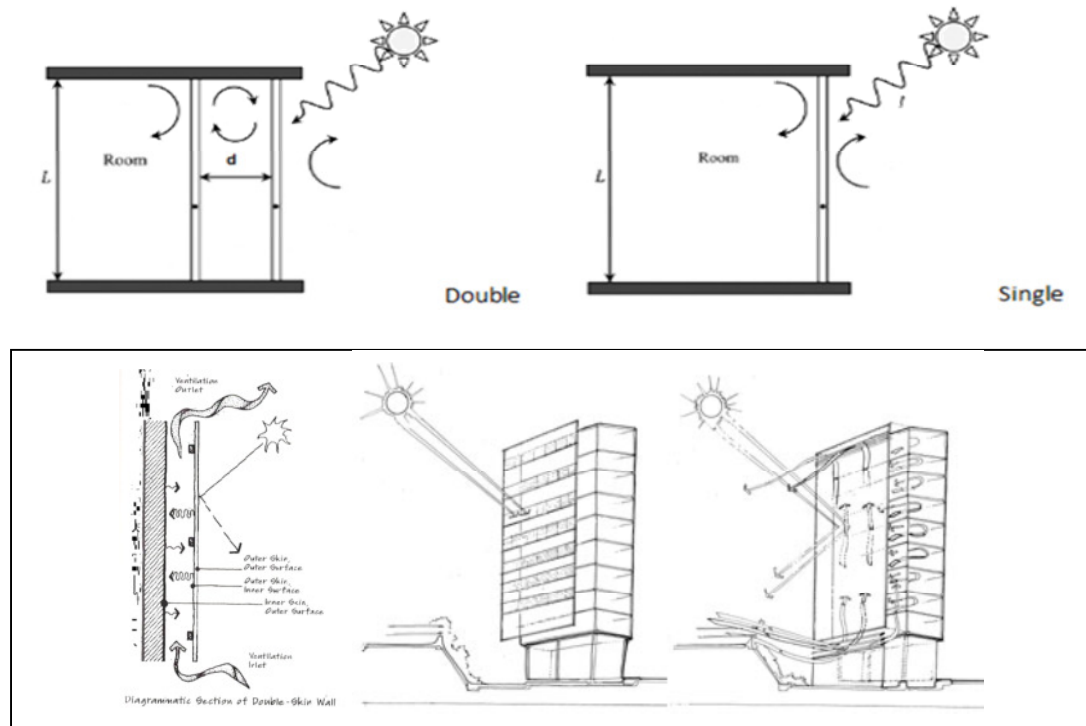

Figure 7: Passive techniques for Double skin façade (Source: <https://www.pinterest.com/pin/146789269080892238/>).

In the present research, the results are presented for double façade with obscure glass. Obscure glass is considered as an efficient kind of glass that permits daylight to enter an interior space while blocking direct rays and minimizes heat gain. It is a plane glass with a surface texture on at least one side of the glass and it is typically transparent, as shown in figure (8). Obscure glass varies in design and optical properties. The most noticeable variation is the geometric design of the surface texture, smooth or rough, and exhibits various larger scale patterns for aesthetic appeal.



Figure 8: Obscure glass used in double skin façade (Source: <http://www.clearglass.com.au/glass-types/acid-etched-glass>).

### 3. Experiment Set Up

#### 3.1 The tested environment

A physical model was made to one of Jordan university of Science and Technology (JUST) typical corridors, figure (9). This corridor with 3.3\*7.8m dimensions as shown in figure (10), oriented to west because of its large heat gain. The width and length of the tested corridor with its balcony measure 3.3 m and 45m respectively. The simulation was made in real sky conditions during the period of time from 1.00-4.00 pm (in one of the sunny days from March) which consider having a maximum magnitude of sunlight according to its vertical direction.



Figure 9: JUST typical corridors (Source: <http://wikimapia.org/14442351/Jordan-University-of-Science-and-Technology-JUST>).

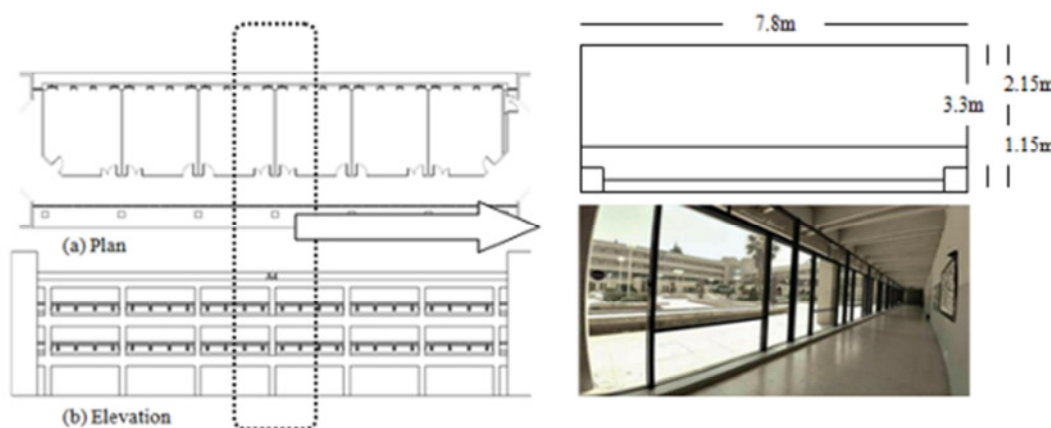

Figure 10: JUST typical corridors' dimensions (Source: <http://www.ccjo.com/Projects/Building/CivicCultural/JORDANSCIENTECHNOLOGYUNIVERSITYCAM/PUS/tabid/488/Default.aspx>, Authors).

### 3.2 Model description and experiments

Two models (scale 1:10) were made to simulate the daylighting environment; the first one acts as a reference case to the existing building's conditions and the second performs the corridor with shading device, both of them were made with movable roof to allow the researcher to put the light meter inside them. Models' materials were chosen to have a reflectance close to the existing materials in real corridor (65% Walls, 43% Floor, and 70% Roof); as shown in the table below.

Table 1: Materials reflectance used in real building and in physical models (Source: By authors).

MATERIALS		Real Building	Physical Models
	Walls	Stain (white)	Paper (white)
	Floor	Off-white tiles	Tiled paper (off-white)
	Roof	Rough concrete	Rough tracing (off-white)
	Glass	Double glazing	1 mm single plastic sheet
REFLECTANCE	Walls	65%	65%
	Floor	43%	40%
	Roof	70%	69%

### 3.2.1 First Experiment: Light shelf (louvers)

In the Light Shelf experiment, two 1:10 scale models were used. The first model forms the reference case, where the second model forms a corridor supplied with horizontal light-shelf, Figure (11).

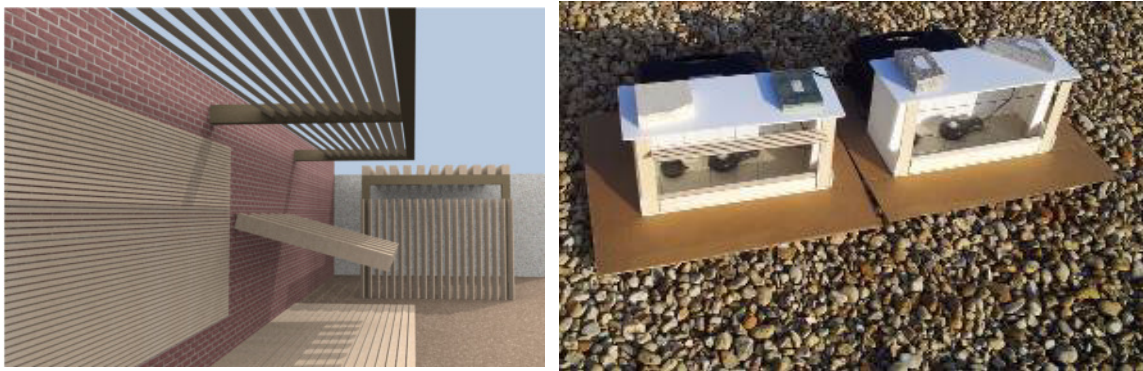

Figure 11: First experiments (light shelf) physical models (Source: By authors).

### 3.2.2 Second Experiment: Egg-crate:

In the Egg-crate experiment, two 1:10 scale models were used. The first model forms the reference case, where the second model forms a corridor supplied with an egg-crate device, Figure (12).



Figure 12: Second experiments (egg-crate) physical models (Source: By authors).

### 3.2.3 Third Experiment: Double facade:

In this experiment, two 1:10 scale models were used. The first model forms the reference case; the second forms the double façade case “decoration panel”, Figure (13).



Figure 13: Third experiments (double facade) physical models (Source: By authors).

#### 4. Measuring Procedure

Two light meters “heavy duty data logging light meter”- one for each model- were used to measure the internal luminance level. Light meter is a small and often portable device for measuring illumination (Merriam-webster.com). It measures illuminance in Lux and Foot candles (Fc). The heavy duty data logging light meter includes a PC interface and Windows™ compatible software for downloading data (Extech.com).

##### 4.1 Meter Description

1. Sensor cable plug
2. USB jack for PC interface (under the flip-down cover)
3. LCD Display
4. Upper function button set
5. Lower function button set
6. Power ON-OFF button
7. Light sensor



Figure 14: Light meter components description (Source: <http://www.extech.com/display/?id=14484>).

##### 4.2 Program Software

Readings taken from the light meter can be stored on the meter for download to a pc. The supplied software allows the user to view readings in real-time on a PC, Figure (15). The readings can be analyzed, zoomed, stored, and printed. The main software screen is shown below for preview (Extech.com).

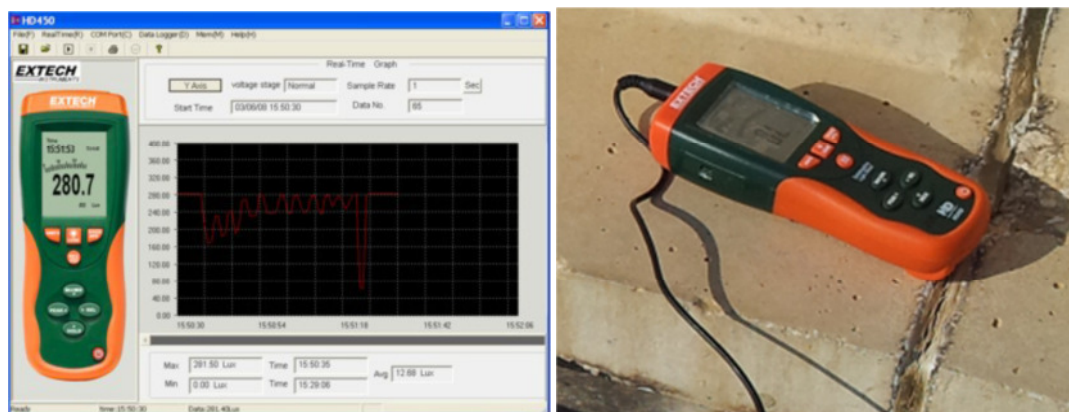

Figure 15: Light meter and its program software (Source: <http://www.extech.com/display/?id=14484>).

#### 5. Measurements' Results and Discussion

When comparing the illumination level of the three installed daylighting devices models with clear glazing illumination model as a reference case from 1:00 to 4:00 pm, the light shelves show about 7%-10% less in illumination rate. While it shows about 30%- 50% less illumination in egg-crate model at the same period. And the illumination level of the double facade obscure glass shows 70%-80% less than the reference model illumination, as shown in the following figures.



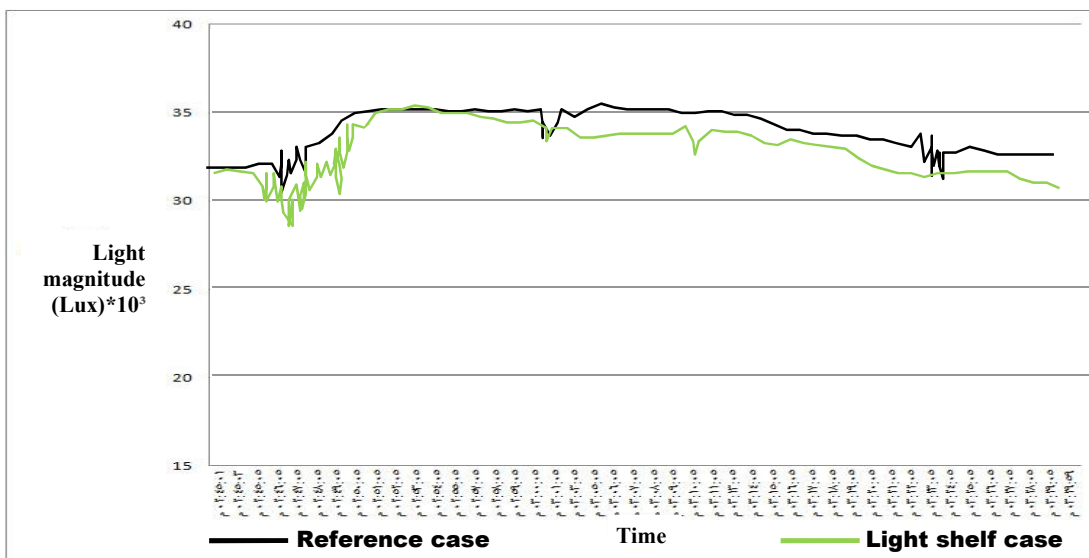

Figure 16: Light shelf experiment result (Source:By authors).

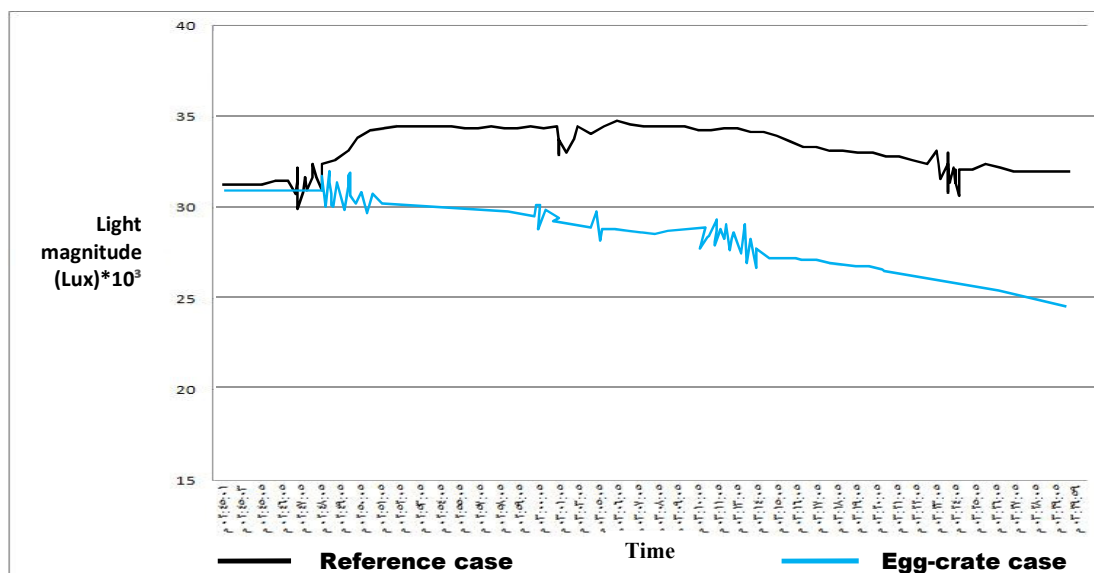

Figure 17: Egg-crate experiment result (Source:By authors).

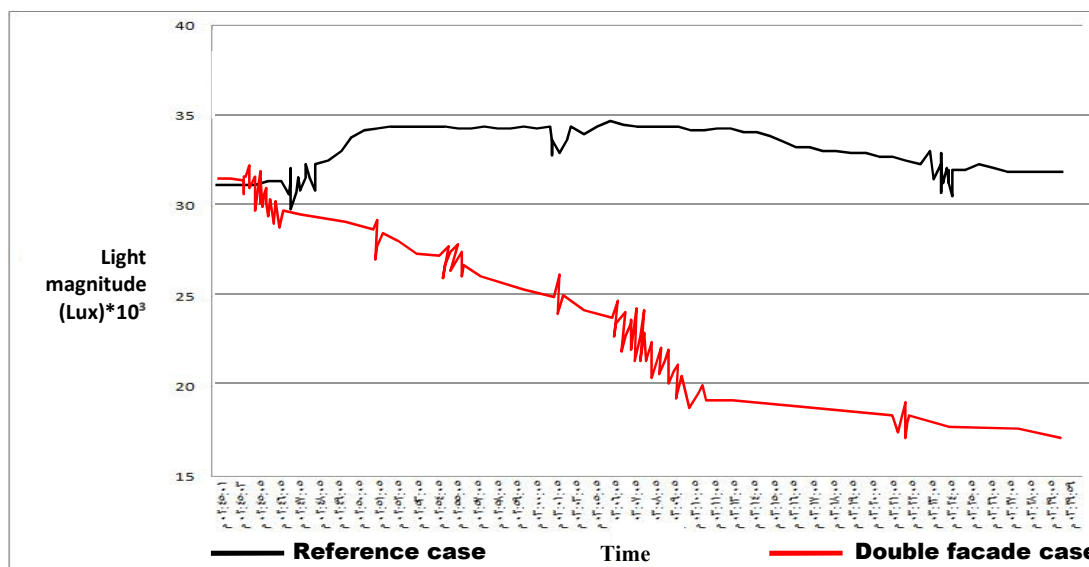

Figure 18: Egg-crate experiment result (Source:By authors).

### Conclusion

The current paper has investigated the impact of three day lighting devices performance on affecting the level of illumination inside a typical corridor in JUST. Physical model experiments were used under real sky conditions. Results showed that when comparing the three tested devices; double facade “textured glass” performed better in reducing the direct amount of light enters the corridor than the other two systems as indicated in the results of the study. And that using egg crate reduces the luminance level and then the gained heat more than the horizontal light shelf (louvers).

### References

- Almssad, A. and A. Almusaed (, 2014). "Efficient daylighting approach by means of light-shelve device adequate for habitat program in Aarhus City." *International Journal of Smart Grid and Clean Energy* 3(4): 441-453.
- Boake, T. M., et al. (, 2003). *Understanding the General Principles of the Double Skin Façade System*, University of Waterloo.
- Ho, M.-C., et al. (, 2008). "Optimal sun-shading design for enhanced daylight illumination of subtropical classrooms." *Energy and buildings* 40(10): 1844-1855.
- Kim, S.-H., et al. (, 2017). "A Study on the Effectiveness of the Horizontal Shading Device Installation for Passive Control of Buildings in South Korea." *International Journal of Polymer Science* 2017.
- Kirankumar, G., et al. (, 2018). *Effect of Various External Shading Devices on Windows for Minimum Heat Gain and Adequate Day lighting into Buildings of Hot and Dry Climatic Zone in India*. MATEC Web of Conferences, EDP Sciences.
- Ogunsote, O. (, 1993). "An Introduction to Building Climatology-A Basic Course for Architecture Students." *Ahmadu Bello University, Zaria*.
- SKAT, S. (, 1993). "Appropriate Building Construction in Tropical and Subtropical Region." *SKAT, Switzerland*.
- Wulfinghoff, D. R. (, 1999). *Energy efficiency manual*, Energy Institute Press Maryland.