

Voltage Dip mitigation in Distribution System by Using D- Statcom

Sambugari Anil Kumar^{1*}, D. vanurrappa²

1. Department of Electrical and Electronics Engineering, G.Pulla Reddy Engineering College, Kurnool-518007, Andhra Pradesh, India
2. Department of Electrical and Electronics Engineering, Brindavan Institute of Technology & Science, Kurnool -518218, Andhra Pradesh, India

* E-mail: sanil.0202@gmail.com

Abstract

A Power quality problem is an occurrence manifested as a nonstandard voltage, current or frequency that results in a failure or a mis-operation of end user equipments. Utility distribution networks, sensitive industrial loads and critical commercial operations suffer from various types of outages and service interruptions which can cost significant financial losses. With the restructuring of power systems and with shifting trend towards distributed and dispersed generation, the issue of power quality is going to take newer dimensions. In developing countries like India, where the variation of power frequency and many such other determinants of power quality are themselves a serious question, it is very vital to take positive steps in this direction. The present work is to identify the prominent concerns in this area and hence the measures that can enhance the quality of the power are recommended.

This work describes the techniques of correcting the supply voltage sag, swell and interruption in a distributed system. At present, a wide range of very flexible controllers, which capitalize on newly available power electronics components, are emerging for custom power applications. Among these, the distribution static compensator and the dynamic voltage restorer are most effective devices, both of them based on the VSC principle. A D-STATCOM injects a current into the system to correct the voltage sag, swell and interruption. Comprehensive results are presented to assess the performance of each device as a potential custom power solution

The STATCOM is applied to regulate transmission voltage to allow greater power flow in a voltage limited transmission network, in the same manner as a static var compensator (SVC), the STATCOM has further potential by giving an inherently faster response and greater output to a system with depressed voltage and offers improved quality of supply. The main applications of the STATCOM are; Distribution STATCOM (D-STATCOM) exhibits high speed control of reactive power to provide voltage stabilization and other type of system control. The DSTATCOM protects the utility transmission or distribution system from voltage sag and /or flicker caused by rapidly varying reactive current demand. During the transient conditions the D-STATCOM provides leading or lagging reactive power to active system stability, power factor correction and load balancing

Keywords: Distribution Static Synchronous Compensator (D-STATCOM), Voltage Dip, Distribution System

1. Introduction

One of the most common power quality problems today is voltage dips. A voltage dip is a short time (10 ms to 1 minute) event during which a reduction in r.m.s voltage magnitude occurs. It is often set only by two parameters, depth/magnitude and duration. The voltage dip magnitude is ranged from 10% to 90% of nominal voltage (which corresponds to 90% to 10% remaining voltage) and with a duration from half a cycle to 1 min. In a three-phase system a voltage dip is by nature a three-phase phenomenon, which affects both the phase-to-ground and phase-to-phase voltages. A voltage dip is caused by a fault in the utility system, a fault within the customer's facility or a large increase of the load current, like starting a motor or transformer energizing. Typical faults are single-phase or multiple-phase short circuits, which leads to high currents. The high current results in a voltage drop over the network impedance. At the fault location the voltage in the faulted phases drops close to zero, whereas in the non-faulted phases it remains more or less unchanged.

Electric power distribution network becomes more increasingly important and plays an essential role in power system planning. This type of power systems has a major function to serve distributed customer loads along a feeder line; therefore under competitive environment of electricity market eservice of electric energy transfer must not be interrupted and at the same time there must provide reliable, stable and high quality of electric power. To complete this challenge, it requires careful design for power network Planning. There exist many different ways to do so. However, one might consider an additional device to be installed somewhere in the network. Such devices are one of capacitor bank, shunt reactor, series reactors, and automatic voltage regulators and/or recently developed dynamic voltage restorers, distribution STATCOM or combination of them.

Most industries and companies prefer electrical energy with high quality. If delivered energy to these loads has poor quality, products and equipment of these loads such as microcontrollers, computers, motor drives etc are damaged. Hurt of this phenomenon in companies that dealing with information technology systems is serious. According to a study in U.S., total damage by voltage sag amounts to 400 Billion Dollars .For these reasons power quality mitigation in power systems is necessary. Nowadays, Custom Power equipments are used for this purpose. DSTATCOM is one of these equipments which can be installed in parallel with. Sensitive loads. This device mitigates the load voltage by Injecting necessary current to the system

2. Structure of Statcom

Basically, STATCOM is comprised of three main parts ,a voltage source inverter (VSI), a step-up coupling transformer, and a controller. In a very-high-voltage system, the leakage inductances of the step-up power transformers can function as coupling reactors. The main purpose of the coupling inductors is to filter out the current harmonic components that are generated mainly by the pulsating output voltage of the power converters.

2.1 Voltage Source Converter (VSC)

A voltage-source converter is a power electronic device, which can generate a sinusoidal voltage with any required magnitude, frequency and phase angle. Voltage source converters are widely used in adjustable-speed drives, but can also be used to mitigate voltage dips. The VSC is used to either completely replace the voltage or to inject the 'missing voltage'. The 'missing voltage' is the difference between the nominal voltage and the actual. The converter is normally based on some kind of energy storage, which will supply the converter with a DC voltage. The solid-state electronics in the converter is then switched to get the desired output voltage. Normally the VSC is not only used for voltage dip mitigation, but also for other power quality issues, e.g. flicker and harmonics.

2.2 A Controller

The aim of the control scheme is to maintain constant voltage magnitude at the point where a sensitive load is connected, under system disturbances. The control system only measures the r.m.s voltage at the load point, i.e., no reactive power measurements are required. The VSC switching strategy is based on a sinusoidal PWM technique which offers simplicity and good response. Since custom power is a relatively low-power application, PWM methods offer a more flexible option than the Fundamental Frequency Switching (FFS) methods favored in FACTS applications. Besides, high switching frequencies can be used to improve on the efficiency of the converter, without incurring significant switching losses.

The controller input is an error signal obtained from the reference voltage and the value rms of the terminal voltage measured. Such error is processed by a PI controller the output is the angle δ , which is provided to the PWM signal generator. It is important to note that in this case, indirectly controlled converter, there is active and reactive power exchange with the network simultaneously: an error signal is obtained by comparing the reference voltage with the rms voltage measured at the load point. The PI controller process the error signal generates the required angle to drive the error to zero, i.e., the load rms voltage is brought back to the reference.

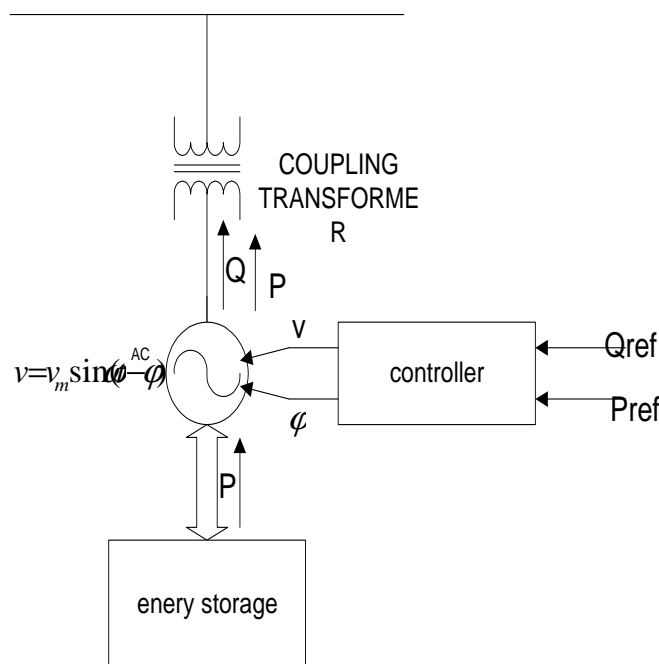

Fig.1 Block diagram representation of STATCOM

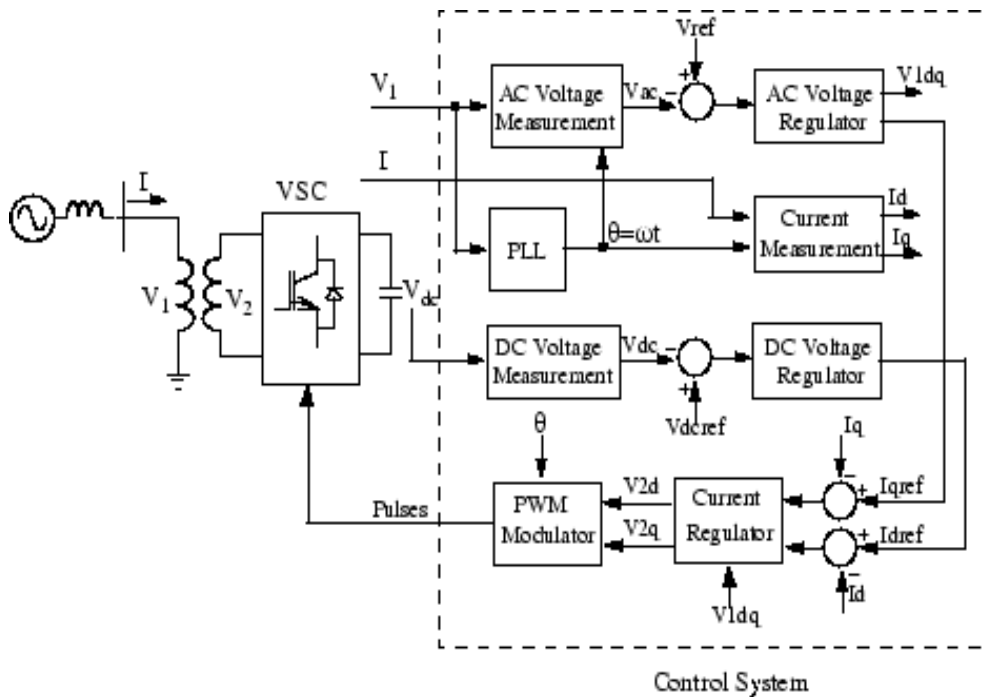

Fig.2 Single-line Diagram of a STATCOM and Its Control System Block Diagram

The control system consists of:

- A phase-locked loop (PLL) which synchronizes on the positive-sequence component of the three-phase primary voltage V_1 . The output of the PLL (angle $\Theta = \omega t$) is used to compute the direct-axis and quadrature-axis components of the AC three-phase voltage and currents (labeled as V_d , V_q or I_d , I_q on the diagram).
- Measurement systems measuring the d and q components of AC positive-sequence voltage and currents to be controlled as well as the DC voltage V_{dc} .
- An outer regulation loop consisting of an AC voltage regulator and a DC voltage regulator. The output of the AC voltage regulator is the reference current I_{qref} for the current regulator (I_q = current in quadrature with voltage which controls reactive power flow). The output of the DC voltage regulator is the reference current I_{dref} for the current regulator (I_d = current in phase with voltage which controls active power flow).
- An inner current regulation loop consisting of a current regulator. The current regulator controls the magnitude and phase of the voltage generated by the PWM converter (V_{2d} V_{2q}) from the I_{dref} and I_{qref} reference currents produced respectively by the DC voltage regulator and the AC voltage regulator (in voltage control mode). The current regulator is assisted by a feed forward type regulator which predicts the V_2 voltage output (V_{2d} V_{2q}) from the V_1 measurement (V_{1d} V_{1q}) and the transformer leakage reactance.

3. Principle of Operation

The D-STATCOM is a three phase and shunt connected power electronics based reactive power Compensation equipment, which generates and /or absorbs the reactive power whose output can be varied so as to maintain control of specific parameters of the electric power system.

The AC voltage difference across the leakage reactance power exchange between the D-STATCOM and the Power system, such that the AC voltages at the busbar can be regulated to improve the voltage profile of the power system, which is primary duty of the D-STATCOM. The D-STATCOM employs an inverter to convert the DC link voltage V_{dc} on the capacitor to a voltage source of adjustable magnitude and phase. Therefore the D-STATCOM can be treated as a voltage controlled source. The D-STATCOM can also be seen as a current controlled source. The basic objective of a VSI is to produce a sinusoidal AC voltage with minimal harmonic distortion from a DC voltage. The operation of the D-STATCOM is as follows: The voltage is compared with the AC bus voltage system (V_s).

- When the AC bus voltage magnitude is above that of the VSI magnitude (V_c); the AC system sees the D-STATCOM as inductance connected to its terminals.
- Otherwise if the VSI voltage magnitude is above that of the AC bus voltage magnitude, the AC system sees the D-STATCOM as capacitance to its terminals.
- If the voltage magnitudes are equal, the reactive power exchange is zero.

If the D-STATCOM has a DC source or energy storage device on its DC side, it can supply real power to the power system. This can be achieved by adjusting the phase angle of the D-STATCOM terminals and the phase angle of the AC power system. When phase angle of the AC power system leads the VSI phase angle, the DSTATCOM absorbs the real power from the AC system, if the phase angle of the AC power system lags the VSI phase angle, the D-STATCOM supplies real power to AC system

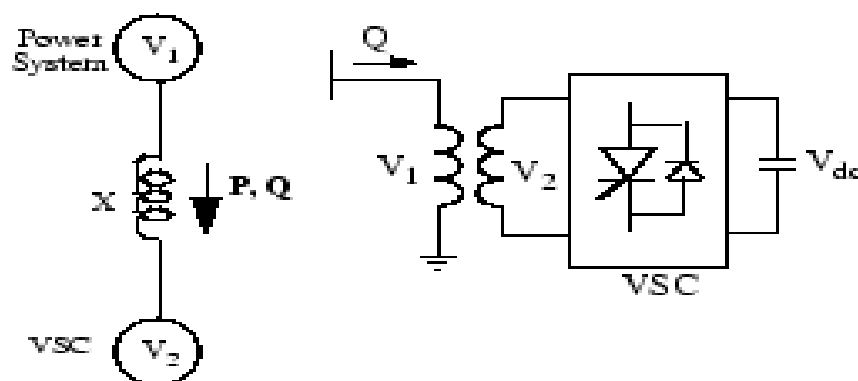

Fig.3 Operating Principle of the STATCOM

4. Compensation schemes

4.1 General Compensation Scheme

A shunt-connected solid-state synchronous voltage source, composed of a six-pulse/five level, voltage-sourced inverter and a dc energy storage device, is shown schematically in Figure 7. As explained in the previous section, it can be considered as a perfect sinusoidal synchronous voltage source behind a coupling

reactance provided by the leakage inductance of the coupling transformer. If the energy storage is of suitable rating, the STATCOM can exchange both reactive and real power with the ac system. The reactive and real power, generated or absorbed by the STATCOM, can be controlled independently of each other, and any combination of real power generation/absorption With var generation/absorption is possible, as illustrated in Figure 7b. The real power that the STATCOM exchanges at its ac terminals with the ac system must, of course, be supplied to, or absorbed from, its dc terminals by the energy storage device. By contrast, the reactive power exchanged is internally generated by the STATCOM, without the dc energy storage device playing any significant part in it.

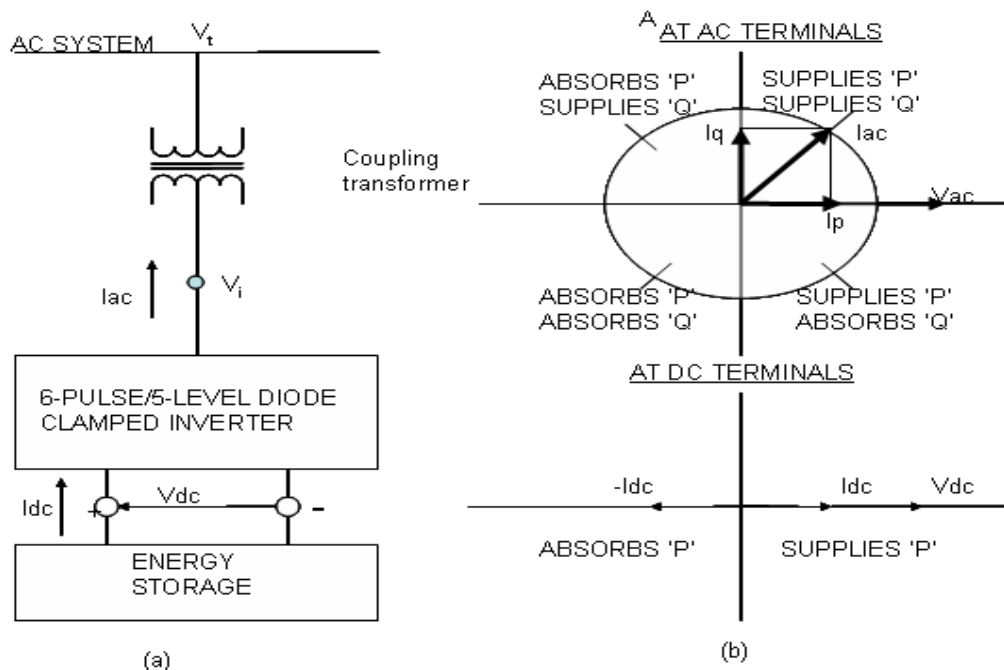

Fig 4: a) shunt connected synchronous voltage source and b) its possible operating modes for real and reactive power generation

4.2 Reactive Power Compensation Scheme

If the D-STATCOM is used only for reactive shunt compensation, like a conventional static var compensator, then the dc energy storage device can be replaced by a relatively small dc capacitor. In this case, the steady-state power exchange between the STATCOM and the ac system can only be reactive.

When the STATCOM is used for reactive power generation, the inverter itself can keep the capacitor charged to the required voltage level. This is accomplished by making the output voltages of the inverter

lag the system voltages by a small angle. In this way the inverter absorbs a small amount of real power from the ac system to replenish its internal losses and keep the capacitor voltage at the desired level. The same control mechanism can be used to increase or decrease dc capacitor voltage, and thereby the amplitude of the output voltage of the inverter, for the purpose of controlling the var generation or absorption

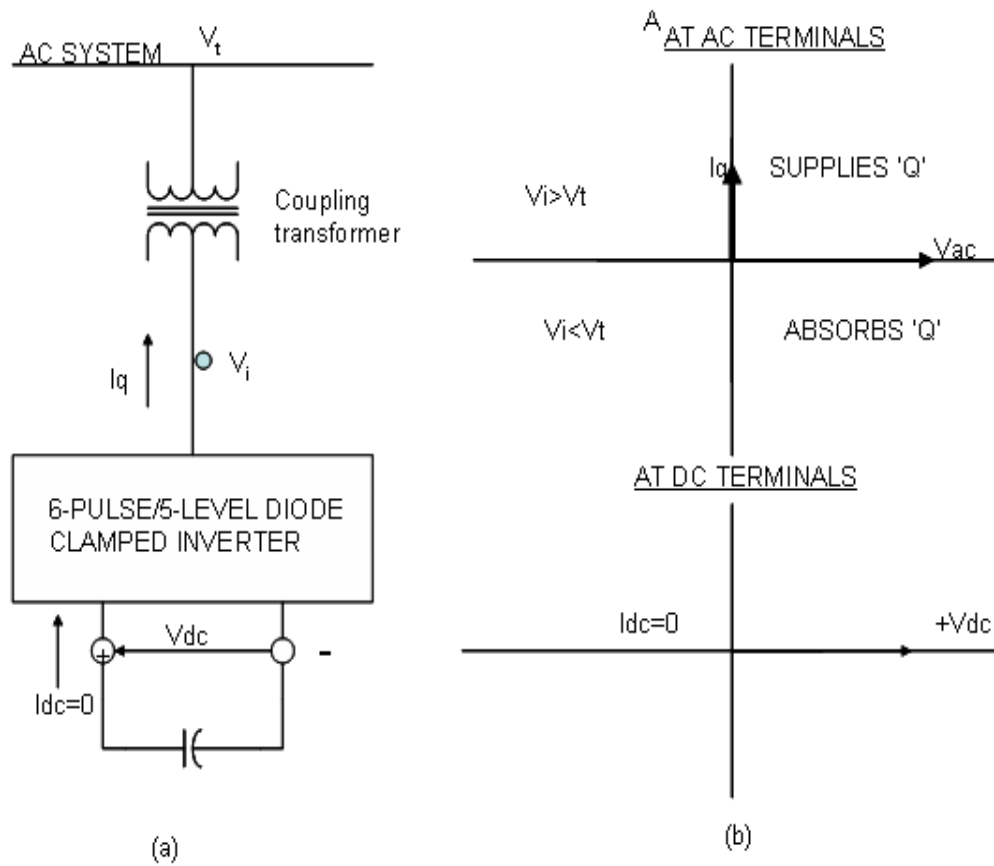
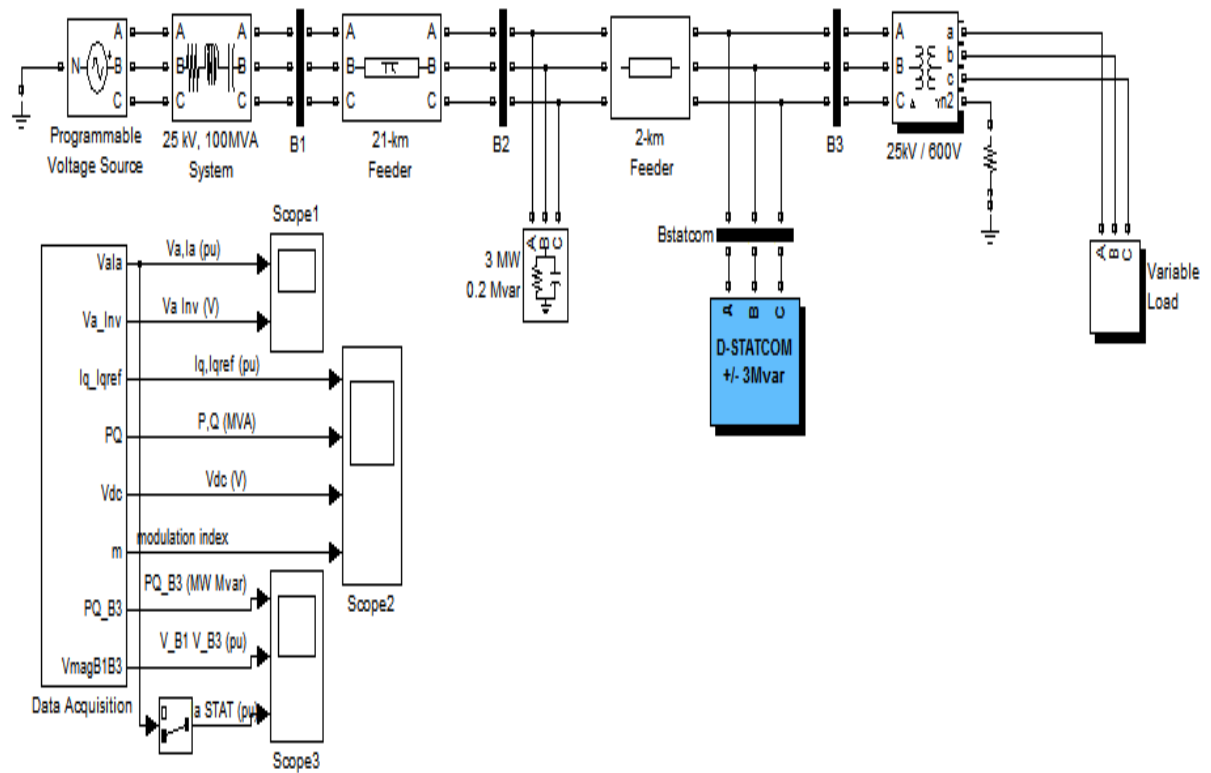

Fig 5.a) synchronous voltage source operated as the static condenser b) its possible operating mode for reactive power generation

5. Simulation Block Diagram of D-Statcom



6. Simulation Results

6.1 Without D-Statcom

Here initially the D-STATCOM was not connected to the system and the load of three phase RLC load

of 3MW, 0.2 MVAR is applied on the system in the time interval of 0.1sec to 0.5 sec. the voltage got dipped from 1.12 p.u to 0.98p.u for voltage across B1 and 1.06 p.u to 0.94 p.u for voltage across B3.

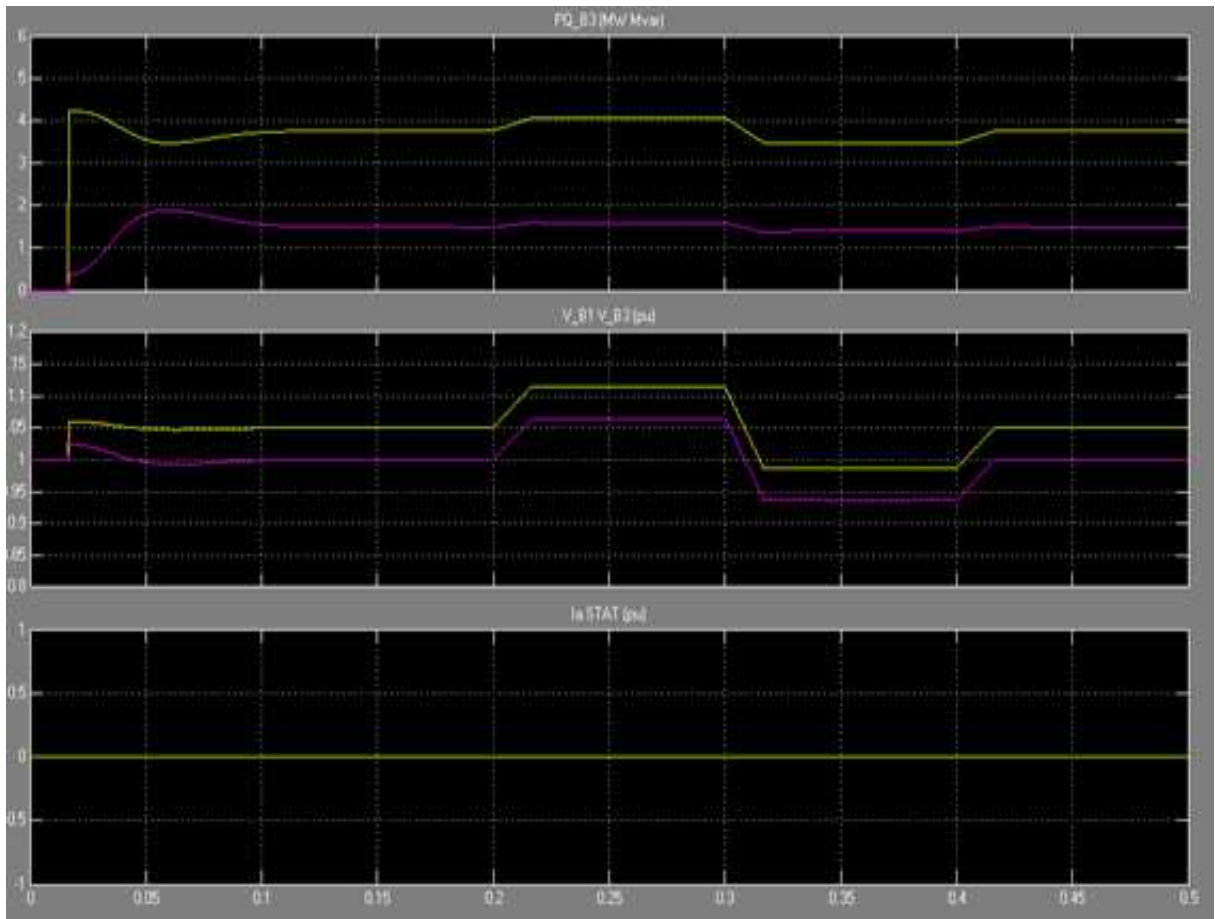

6.2 With D-Statcom

Here the D-STATCOM was connected to the system and the load of three phase RLC load of 3MW, 0.2 MVAR is applied on the system in the time interval of 0.1sec to 0.5 sec. the voltage got dipped from 1.09 p.u to 1.01p.u for voltage across B1 and 1.02 p.u to 0.96 p.u for voltage across B3

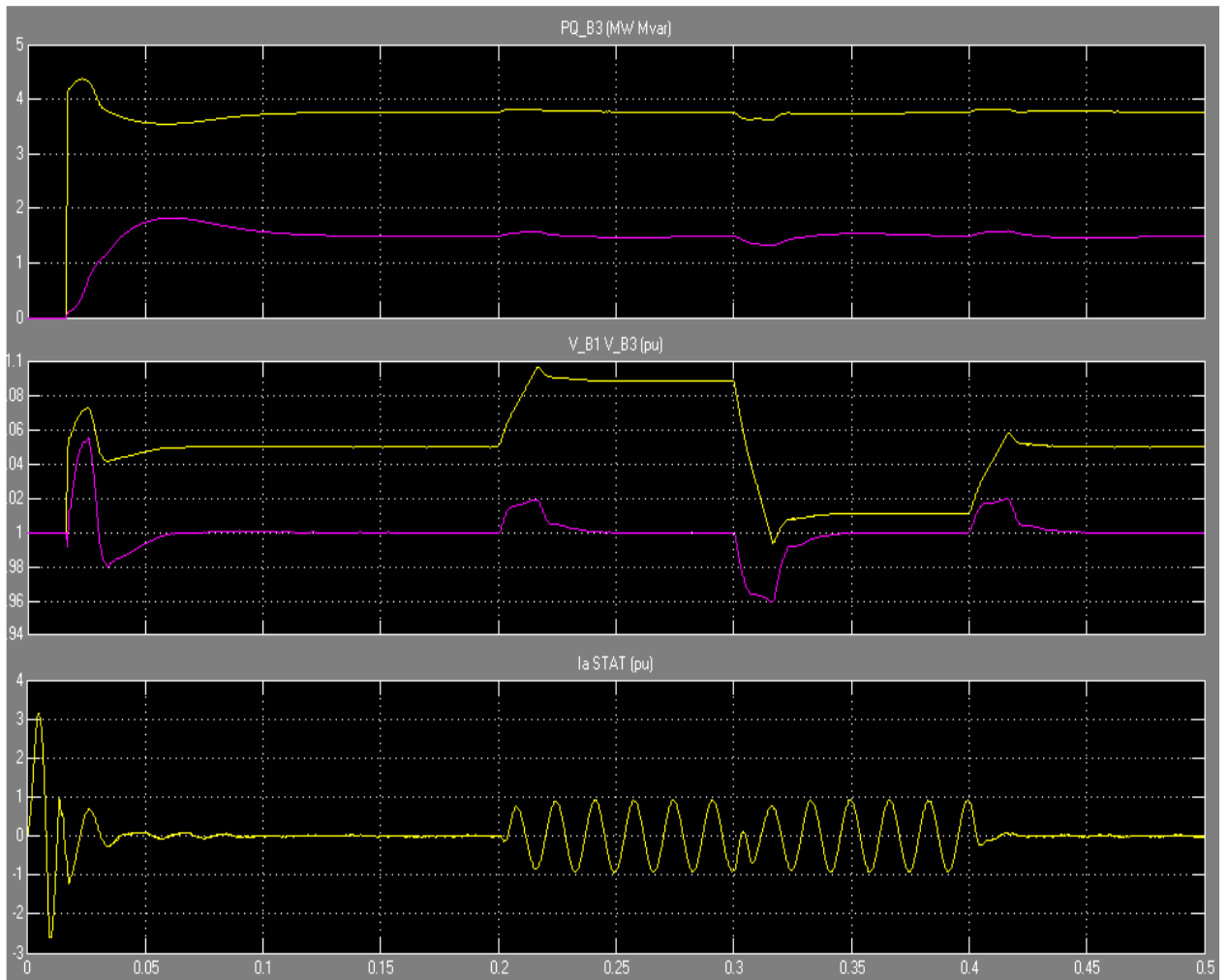

7. Conclusion

Voltage dip and voltage flickering are the two major power quality problems which are frequently seen in the distribution systems. These power quality problems in 25KV, 100 MVA distribution system are investigated in this paper. The analysis and simulation of a DSTATCOM application for the mitigation of power quality problems are presented and discussed. The Mat lab Power System Block set simulation results shows that the mitigation of the power quality problems (voltage dip and the voltage flickering) done effectively with D-STATCOM. The voltage got dipped from 1.12 p.u to 0.98p.u for voltage across B1 and 1.06 p.u to 0.94 p.u for voltage across B3 for without D-Statcom and 1.09 p.u to 1.01p.u for voltage

across B1 and 1.02 p.u to 0.96 p.u for voltage across B3 with D-Statcom.

References

- G.Yaleinkaya, M.H.J. Bollen, P.A. Crossley (1999), "Characterization of voltage sags in industrial distribution systems", IEEE transactions on industry applications, vol.34, no. 4, July/August, pp. 682-688.
- Hague, M.H (2001), "Compensation of distribution system voltage sag by DVR and D-STATCOM", Power Tech Proceedings, 2001 IEEE Porto, vol.1, pp.10-13, Sept.
- Peter Ashmole and Paul Amante (1997), "System Flicker Disturbances from Industrial Loads and Their Compensation," Power Engineering Journal, pp. 213-218, Oct.
- W. N. Chang, C. J. Wu, and S. S. Yen (1998), "A Flexible Voltage Flicker Teaching Facility for Electric Power Quality Education," IEEE Trans.Power Systems, vol. 13, pp. 27-33, Feb.
- M. K. Walker (1979), "Electric Utility Flicker Limitations", IEEE Trans.Industrial Applications, vol. 15, pp. 644-655, Nov.
- Laszlo Gyugyi (1994), "Dynamic compensation of ac transmission lines by solid-state synchronous voltage sources" IEEE transactions on power delivery, vol.9, no.2, pp.904-911, April.
- Pirre giroux, G.sybille, Hoang le-huy (2001),"Modeling and simulation of a D-STATCOM using simulink's power system blockset" The 27th annual conference of the IEEE industrial electronics society, pp990-994.
- Anaya-Lara O, Acha E (2002), "Modeling and analysis of custom power systems by PSCAD/EMTDC", IEEE Transactions on Power Delivery, Vol.17, and Issue: 1, Jan., Pages: 266 – 272.
- R.Miensi, R.Pawelek and I.Wasiak (2004), "Shunt Compensation for Power Quality Improvement Using a STATCOM controller: Modeling and Simulation", IEEE Proce., Vol.151, No.2, March

S.Anil Kumar was born in India in 1986. He received his B.Tech in Electrical & Electronics Engineering from Jawaharlal Nehru Technological University, Hyderabad in 2007. He is pursuing his Master of Technology in Electrical power systems from the Jawaharlal Nehru Technological University, Anantapur. He is currently working as an Assistant Professor in Electrical and Electronics Engineering Department at G.Pulla Reddy Engineering College, Kurnool. His Research interests include electric power distribution systems, HVDC, FACTS and Power system operation and control.

D.Vanurrappa was born in India in 1982. He received his B.Tech in Electrical & Electronics Engineering from Jawaharlal Nehru Technological University, Hyderabad in 2007. He is pursuing his Master of Technology in Electrical power systems from the Jawaharlal Nehru Technological University, Anantapur. He is currently working as an Assistant Professor in Electrical and Electronics Engineering Department at Brindavan Institute of Technology & Sciences, Kurnool. His Research interests include electric power distribution systems, HVDC, FACTS and Power system operation and control.

This academic article was published by The International Institute for Science, Technology and Education (IISTE). The IISTE is a pioneer in the Open Access Publishing service based in the U.S. and Europe. The aim of the institute is Accelerating Global Knowledge Sharing.

More information about the publisher can be found in the IISTE's homepage:

<http://www.iiste.org>

The IISTE is currently hosting more than 30 peer-reviewed academic journals and collaborating with academic institutions around the world. **Prospective authors of IISTE journals can find the submission instruction on the following page:**

<http://www.iiste.org/Journals/>

The IISTE editorial team promises to review and publish all the qualified submissions in a fast manner. All the journals articles are available online to the readers all over the world without financial, legal, or technical barriers other than those inseparable from gaining access to the internet itself. Printed version of the journals is also available upon request of readers and authors.

IISTE Knowledge Sharing Partners

EBSCO, Index Copernicus, Ulrich's Periodicals Directory, JournalTOCS, PKP Open Archives Harvester, Bielefeld Academic Search Engine, Elektronische Zeitschriftenbibliothek EZB, Open J-Gate, OCLC WorldCat, Universe Digital Library, NewJour, Google Scholar

