

## Smart Antennas Implementation for MIMO

Suraya Mubeen<sup>1\*</sup>, A.M.Prasad<sup>2</sup>, A.Jhansi Rani<sup>3</sup>

1. KL UNIVERSITY ASSISTANT PROFESSOR ECE VIJAYAWADA ANDHRA PRADESH INDIA

2 .JNTU KAKINADA PROFESSOR ECE KAKINADA

3 .VRSEC PROFESSOR ECE VIJAYAWADA

\*Email of the corresponding author: SURAYA418@GMAIL.COM

### Abstract

MIMO systems place the same requirements on the RF link as do the receive diversity systems that are in place for current cellular networks, that is, there must be de-correlation between the channels received at the antenna. This de-correlation is provided by space diversity when achieved by the separation of the antennas, or by the use of polarization diversity when implemented by the use of orthogonal antenna elements. However, for dual-pole antennas, cross-polar discrimination and port-to-port isolations can affect the diversity or MIMO performance of the system by introducing correlation between the channels. MIMO systems employing smart antennas are a promising candidate for future mobile communications due to their tremendous spectral efficiency. RF engineers have to find new antenna solutions for MIMO applications, especially the integration of MIMO antennas into small handsets is a challenging task. Smart antenna systems may revolutionize future communications systems. So far, only the spectrum, the time and the code domain are exploited for communications systems. The resources spectrum and code are very limited. Smart antennas exploit the spatial domain, which has been almost completely unused so far. For multiplex transmission within one communications link, i.e. a parallel transmission of several data streams at the same time and frequency only separated by the spatial domain, multiple transmit and multiple receive antennas (multiple input multiple output - MIMO) are required. MIMO systems promise to reach very large data rates and therewith high spectral efficiencies. The proposed research work states smart antennas for mimo's and related for wireless systems.

**Keywords:**MIMO,SISO,DIVERSITY

### 1.Introduction:

MIMO technology leverages multipath behavior by using multiple, “smart” transmitters and receivers with an added “spatial” dimension to dramatically increase performance and range. MIMO allows multiple antennas to send and receive multiple spatial streams at the same time. This allows antennas to transmit and receive simultaneously. MIMO makes antennas work smarter by enabling them to combine data streams arriving from different paths and at different times to effectively increase receiver signal-capturing power. Smart antennas use spatial diversity technology, which puts surplus antennas to good use. If there are more antennas than spatial streams, as in a 2x3 (two transmitting, three receiving) antenna configuration, then the third antenna can add receiver diversity and increase range. In order to implement MIMO, either the station (mobile device) or the access point (AP) need to support MIMO. Optimal performance and range can only be obtained when both the station and the AP support MIMO. Legacy wireless devices can't take advantage of multipath because they use a Single Input, Single Output (SISO) technology. Systems that use SISO can only send or receive a single spatial stream at one time.

## 2. MIMO Types:

Multi-antenna MIMO (or Single user MIMO) technology has been mainly developed and is implemented in some standards, e.g. 802.11n products. SISO/SIMO/MISO are degenerate cases of MIMO Multiple-input and single-output (MISO) is a degenerate case when the receiver has a single antenna. Single-input and multiple-output (SIMO) is a degenerate case when the transmitter has a single antenna. Single-input single-output (SISO) is a radio system where neither the transmitter nor receiver has multiple antennas.

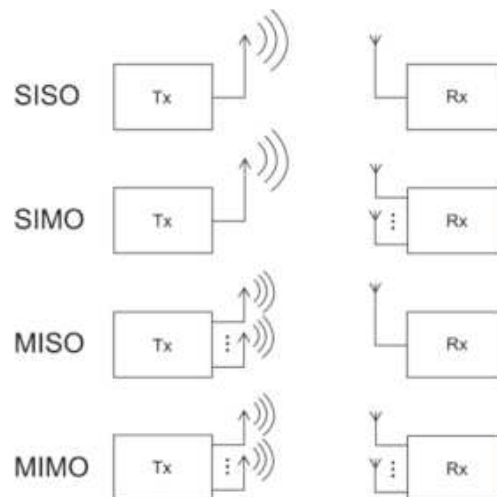

Figure 1: Different MIMO'S AND SISO'S

**3.MIMO FUNCTIONS:** MIMO can be sub-divided into three main categories, precoding, spatial multiplexing or SM, and diversity coding

3.1.Precoding: It is multi-layer beam forming in a narrow sense or all spatial processing at the transmitter in a wide-sense. In (single-layer) beam forming, the same signal is emitted from each of the transmit antennas with appropriate phase (and sometimes gain) weighting such that the signal power is maximized at the receiver input. The benefits of beam forming are to increase the signal gain from constructive combining and to reduce the multipath fading effect. In the absence of scattering, beam forming results in a well defined directional pattern, but in typical cellular conventional beams are not a good analogy. When the receiver has multiple antennas, the transmit beam forming cannot simultaneously maximize the signal level at all of the receive antennas, and precoding is used. Note that precoding requires knowledge of the channel state information (CSI) at the transmitter.

3.2. Spatial multiplexing: This requires MIMO antenna configuration. In spatial multiplexing, a high rate signal is split into multiple lower rate streams and each stream is transmitted from a different transmit antenna in the same frequency channel. If these signals arrive at the receiver antenna array with sufficiently different spatial signatures, the receiver can separate these streams, creating parallel channels free. Spatial multiplexing is a very powerful technique for increasing channel capacity at higher Signal to Noise Ratio (SNR). The maximum number of spatial streams is limited by the lesser in the number of antennas at the transmitter or receiver. Spatial multiplexing can be used with or without transmit channel knowledge. Spatial multiplexing is not intended to make the transmission more robust; rather it increases the data rate. To do this, data is divided into separate streams; the streams are transmitted independently via separate antennas. Because MIMO transmits via the same channel, transmissions using

cross components not equal to 0 will mutually influence one another.

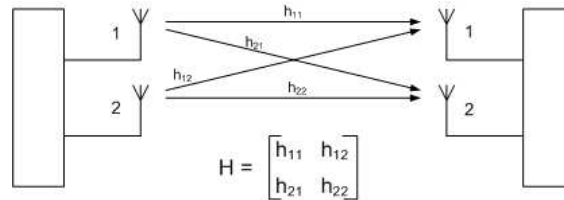

Figure 2 :MIMO 2x2 antenna configuration

If transmission matrix  $H$  is known, the cross components can be calculated on the receiver. In the open-loop method, the transmission includes special sections that are also known to the receiver. The receiver can perform a channel estimation. In the closed-loop method, the receiver reports the channel status to the transmitter via a special feedback channel. This makes it possible to respond to changing circumstances.

3.3. Signal Diversity Coding: These techniques are used when there is no channel knowledge at the transmitter. In diversity methods a single stream (unlike multiple streams in spatial multiplexing) is transmitted, but the signal is coded using techniques called space-time coding. The signal is emitted from each of the transmit antennas using certain principles of full or near orthogonal coding. Diversity exploits the independent fading in the multiple antenna links to enhance signal diversity. Because there is no channel knowledge, there is no beam forming or array gain from diversity coding. The purpose of spatial diversity is to make the transmission more robust. There is no increase in the data rate. This mode uses redundant data on different paths.

**4.RX Diversity:**

RX diversity uses more antennas on the receiver side than on the transmitter side. The simplest scenario consists of two RX and one TX antenna (SIMO, 1x2).

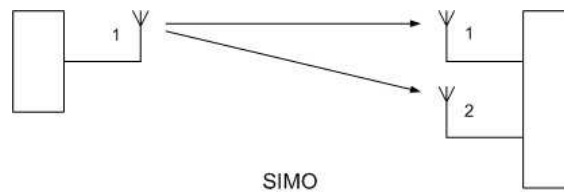
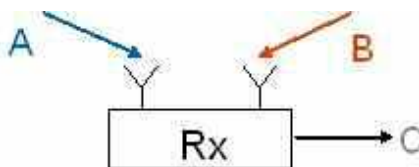

Figure 3: SIMO antenna configuration

Because special coding methods are not needed, this scenario is very easy to implement. Only two RF paths are needed for the receiver.



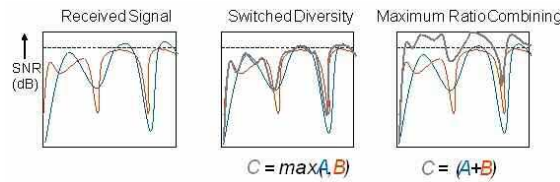

Figure 4 : RX diversity

Because of the different transmission paths, the receiver sees two differently faded signals. By using the appropriate method in the receiver, the signal-to-noise ratio can now be increased. Switched diversity always uses the stronger signal, while maximum ratio combining uses the sum signal from the two signals

4.1. TX Diversity: When there are more TX than RX antennas, this is called TX diversity. The simplest scenario uses two TX and one RX antenna (MISO, 2x1).

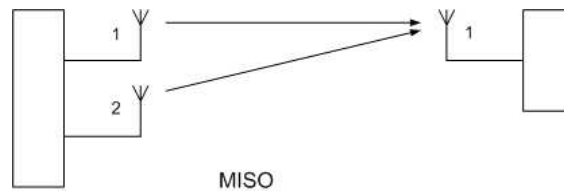

Figure 5: MISO antenna configuration

In this case, the same data is transmitted redundantly over two antennas. This method has the advantage that the multiple antennas and redundancy coding is moved from the mobile UE to the base station, where these technologies are simpler and cheaper to implement. To generate a redundant signal, space-time codes are used. A simple way to appreciate the benefits of MIMO is to consider the Shannon limit on the capacity (in bits/s/Hz) of a given channel between a transmitter and receiver. This is well known to be

$$C = \log_2 (1 + SNR) \quad (1)$$

Using M transmitters and M receivers, but reducing the power transmitted from any one transmitter to maintain the same total transmit power as the single antenna case, then the total capacity limit between M transmitters and M receivers becomes:

$$C_M = M \cdot \log_2 \left( 1 + \frac{SNR}{M} \right) \quad (2)$$

## 5. MIMO Antennas: Diversity

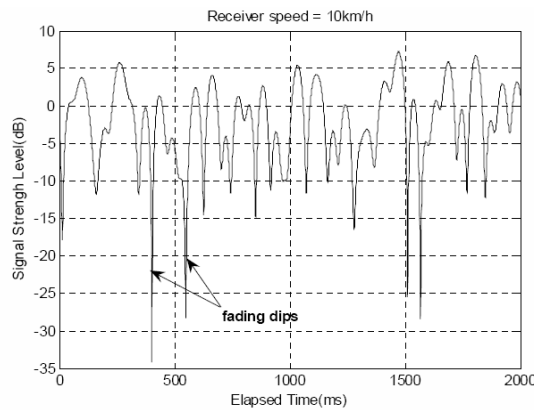

Figure 6:MATLAB Result for signal strength and time

Multi-path signal transmission may lead to destructive signal overlay resulting in local deep dips (called Rayleigh-Fading) From the correlation a diversity gain of a MIMO antenna system can be defined based on statistic assumptions.

$$G_{app} = 10 \cdot \sqrt{1 - |\rho|^2} \quad (3)$$

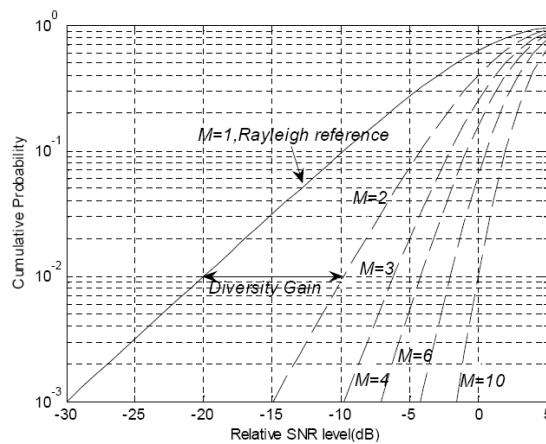

Figure 7:MATLAB Result for SNR and probability

## 6. Smart Antenna Planning Example

In this section, we discuss a specific planning problem through a simulation study. We discuss the connectivity of users in a 3G cellular network with conventional sectorization and compare it with the connectivity when the network deploys 4-element uniform linear array antennas. Specifically, we assume a UMTS radio access network configuration including approximately 100 sectors. In order to investigate the system performance ,system-level simulations were carried out using a state-of-the-art Monte Carlo simulator. The system-level simulator models the network similarly to most of the commercially available radio network planning tools. Additionally, we included the modeling of smart antenna processing. In the first scenario, we consider all base stations to be equipped with

conventional sector antennas (three sectors per site). In the second scenario, the base stations are equipped with 4-element uniform linear array antennas. In the second scenario, we assume that the baseband signal processing at the base station implements optimum combining. The typical questions to be answered by the operator are:

- How do smart antennas influence the system performance?
- In which regions are disconnected users concentrated?
- Does the distribution of disconnected users change in the case of smart antenna deployment?
- Does it make sense to deploy smart antennas throughout the entire network or only in certain areas?

For simplicity we assume an idealized service mix with just two different service types, i.e., we assume 40% of the users to be served at a data rate of 12.2 kbit/s and 60% of the users at 64 kbit/s.

The results are shown in Figure:8 shows the distribution of the connected users for conventional sector antennas (a) and 4-element-ULAs (b). Conversely, Figure: 9 shows the distribution of disconnected users in case of conventional sector antennas (a) and 4-element- ULAs (b). This comparison shows that smart antennas are capable of increasing the number of served users. Hence, the network's aggregated throughput can be increased substantially by the use of smart antennas. In the studied scenario, the deployment of 4-element-ULAs is capable of doubling the network throughput. Only a very small number of users remain disconnected in areas of poor coverage. We note that smart antennas provide a "cluster gain," rather than just a performance gain limited to the smart antenna serving cell. This means that a single cell equipped with a smart antenna will not just improve the coverage and capacity of the serving sector, but will also improve the performance of the neighboring cells, due to the highly reduced inter cell interference power.

Recently, a statistical analysis in live CDMA networks was carried out in North America [22]. The analysis has shown that among all sites in which the load exceeds the capacity threshold, around 51% have a single overloaded sector, while the other sectors operate below the capacity threshold. Another 38% of the sites have two sectors exceeding the capacity threshold, and only 11% of the sites have all three sectors exceeding the capacity threshold. This means that, when deployed per sector, smart antennas allow the operator to address capacity where additional resources are needed, increasing the utilization of every deployed carrier.

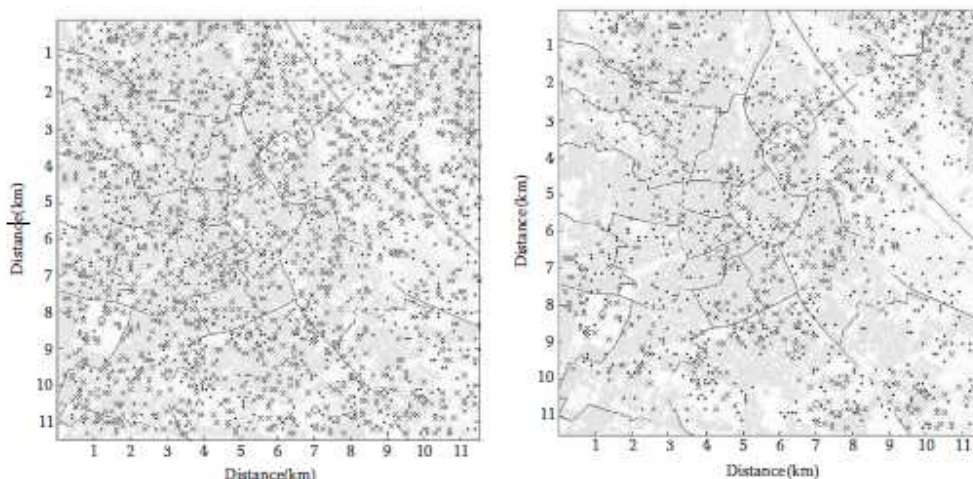

Figure 8; Distribution of connected users in the system area. Each base station is either equipped with a single element sector antenna (a) or a 4-element uniform linear array (ULA, performing optimum combining) (b), respectively. The "." indicates users with a 12.2 kbit/s service, and the "x" shows users with 64 kbit/s service.

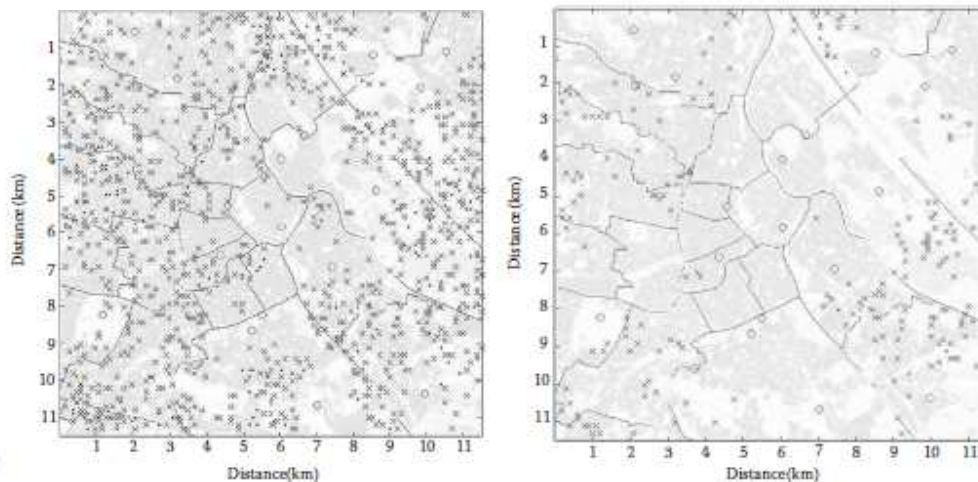

Figure 9; Distribution of disconnected users in the system area. Each base station is either equipped with a single element sector antenna (a), or a 4-element uniform linear array (ULA, performing optimum combining) (b), respectively. The “.” indicates users with a 12.2 kbit/s service, and the “x” shows users with 64 kbit/s service.

**7 .Conclusion:** Considering both the sector-based capacity limitations and the cluster gain of smart antennas, future challenges for smart antenna and MIMO radio network deployment. We have presented a development platform for MIMO systems and smart antennas, which contains With those technologies it is possible to improve the signal-to-noise ratio at the receiver and increase capacity in mobile radio systems. A variety of smart antennas, from those with MIMO as well as active antenna array antenna configurations have been reviewed in great depth. Their installation and operational characteristics have been detailed and several deployment and upgrade strategies have been discussed.

#### References:

- [1]. 3GPP TSG RAN Future Evolution Workshop, November 2005
- [2]. P.F. Driessen and L.J. Greenstein. 1995. “Modulation techniques for high-speed wireless indoor systems using narrowbeam antennas,” *IEEE Transactions on Communications*, Vol. 43, No. 10, Oct. 1995.
- [3]. C. Evcı, A. de Hoz, R. Rheinschmitt, M. Araki, M. Umehira, M.A. Beach, P. Hafezi, A. Nix, Y. Sun, S. Barberis, E. Gaiani, B. Melis, G. Romano, V. Palestini, and M. Tolonen. 1999. “AWACS: system description and main project achievements,” *Proceedings ACTS Mobile Communications Summit*, Sorrento, Italy, June 8–11, 1999.
- [4]. G. Grosskopf, A. Norrdine, D. Rohde, and M. Schlosser. 2004. “Gigabit Ethernet Transmission Experiments at 60 GHz,” *Proceedings 13th International Plastic Optical Fibres Conference*, Nurnberg, Germany, Sept. 2004 (on CD-ROM).
- [5]. D.R. Wisely. 1996. “A 1 Gbit/s optical wireless tracked architecture for ATM delivery,” *Proceedings IEE Colloquium on Optical Free Space Communication Links*, London, pp. 14/1–7.
- [6]. C.B. Papadias and H. Huang. 2001. “Linear space-time multiuser detection for multipath CDMA channels,” *IEEE Journal of Selected Areas in Communications*, Vol. 19, No. 2, pp. 254–265.
- [7]. V. Jungnickel, H. Chen, and V. Pohl. 2005. “A MIMO RAKE receiver with enhanced interference cancellation,”

Proceedings Vehicular Technology Conference (VTC Spring), Stockholm, Sweden, May 30–June 2, 2005 (on CD-ROM).

- [8]. G.G. Raleigh and J.M. Cioffi. 1998. “Spatio-temporal coding for wireless communications,” IEEE Transactions on Communications, Vol. 46, No. 3, March 1998.
- [9]. A. van Zelst and T. C.W. Schenk. 2004. “Implementation of a MIMO OFDM based wireless LAN system,” IEEE Transactions on Signal Processing, Vol. 52, No. 2, Feb. 2004, pp. 483–494.
- [10]. W. Xiang, D. Waters, T.G. Pratt, J. Barry, and B. Walkenhorst. 2004. “Implementation and experimental results of a three-transmitter three-receiver OFDM/BLAST testbed,” IEEE Communications Magazine, Vol. 42, No. 12, Dec. 2004, pp. 88–95.
- [11]. C. Dubuc, D. Starks, T. Creasy, and Y. Hou. 2004. “A MIMO-OFDM prototype for next generation wireless WANS,” IEEE Communications Magazine, Vol. 42, No. 12, Dec. 2004, pp. 82–87.
- [12]. K. Mizutani, K. Sakaguchi, J. Takada, and K. Araki. 2004. “Development of  $4 \times 4$  MIMO-OFDM system and test measurements,” Proceedings 12th European Signal Processing Conference (EUSIPCO), Vienna, Austria, Sept. 6–10, 2004 (on CD-ROM).
- [13]. S. Hane, D. Perels, D.S. Baum, M. Borgmann, A. Burg, N. Felber, W. Fichtner, and H. Bolcskei. 2004. “Implementation aspects of a real-time multi-terminal MIMO-OFDM testbed,” Proceedings IEEE Radio and Wireless Conference (RAWCON), Atlanta, GA, Sept. 2004 (on CD-ROM).
- [14]. V. Jungnickel, T. Haustein, A. Forck, U. Krueger, V. Pohl, and C. von Helmolt. 2004. “Over-the-air demonstration of spatial multiplexing at high data rates using real-time base-band processing,” Advances in Radio Science, Vol. 2, pp. 135–140



This academic article was published by The International Institute for Science, Technology and Education (IISTE). The IISTE is a pioneer in the Open Access Publishing service based in the U.S. and Europe. The aim of the institute is Accelerating Global Knowledge Sharing.

More information about the publisher can be found in the IISTE's homepage:

<http://www.iiste.org>

The IISTE is currently hosting more than 30 peer-reviewed academic journals and collaborating with academic institutions around the world. **Prospective authors of IISTE journals can find the submission instruction on the following page:**

<http://www.iiste.org/Journals/>

The IISTE editorial team promises to review and publish all the qualified submissions in a fast manner. All the journals articles are available online to the readers all over the world without financial, legal, or technical barriers other than those inseparable from gaining access to the internet itself. Printed version of the journals is also available upon request of readers and authors.

### **IISTE Knowledge Sharing Partners**

EBSCO, Index Copernicus, Ulrich's Periodicals Directory, JournalTOCS, PKP Open Archives Harvester, Bielefeld Academic Search Engine, Elektronische Zeitschriftenbibliothek EZB, Open J-Gate, OCLC WorldCat, Universe Digital Library, NewJour, Google Scholar

