

# Exploring the Feasibility of Adopting Cloud Computing in Computer Center Taiz University

The Center for Graduate Studies  
Taiz University, Republic of Yemen

Mohammed A.M. Ibrahim  
Email:sabri1966@yahoo.com  
Alsabry, Fatimah, Ameen

## Abstract

The paper would discuss the possibilities of using cloud computing as a solution to expand work efficiency at Taiz university (TU) Computer Center and Information Technology (CCIT) labs, these Labs equipped with hardware and software resources. Cloud computing has been adopted for managing the labs to facilitate maintenance and network management according to cloud computing characteristics, also paper has studied the different types of cloud-based computing to decide the appropriate type that would gain significant advantages for students and lecturers. Surely result of this paper will be the guideline for all universities in Yemen to use the cloud computing in different areas of their work.

**Keywords:** Distributed computing system , Network computing ,Cloud Computing, Infrastructure As A Service (IAAS) layer, Platform As A Service (PAAS) layer, Software As A Service (SAAS) layer, private cloud, public cloud, hybrid cloud.

## 1. Introduction

Recently cloud computing has offered attractive solutions for many organizations especially academic and research institutions to get their applications up and running faster, with improved manageability however software ,hardware maintenance efforts and reducing the expenditures are features motivated us to used cloud computing as a solution to expand work efficiency of the labs and managements works at Taiz University Computer Center & Information Technology (CCIT) funds limitation are crucial problem . This paper will propose the adoption of cloud computing to be a solution for managing software, hardware and network management in computer labs for facilitate maintenance efforts according to cloud computing characteristics.

The proposed model of cloud computing will focus on the most famed free cloud services, free IDEs and private clouds. Although cloud computing provides dependable and secured data storage which we will not discuss in this paper. The main focusing on exploring the feasibility of adopting cloud computing in CCIT labs as a solution to facilitate the maintaining, learning, and teaching activities. Furthermore, to choose the appropriate model with compliance of the maintenance management then identifies the challenges and proposes a roadmap that will act as a guideline for technical and business managers when evaluating a cloud adoption model. IT professionals in computer center need to respond quickly to increasing demands from students and lecturers, which make the maintaining of dozens of computers to become a burden task for them with fixed budgets and staff.

In this challenging environment, cloud-based computing has become an increasingly attractive option for delivering education services to develop the teaching network management and facilitate the environment of IT education with more availability, reliably, and economically via remote access to the computing resources or services provided by cloud providers through a web browser or other remote desktop accessing mechanisms.

Distributed computing system use several technologies for solve complex issues based on computer networks [1,2] thus technologies are Utility Computing, Cluster Computing, Grid Computing ,Distributed Computing and Cloud Computing. Intensive research works are being performed. Most researchers believed that cloud-computing technology will replace traditional IT systems, in other hand cloud computing is cheapest technology and economically if compared to the abovementioned technologies and also a cloud computing system serving for processing and storing of user data, by clustering and virtualization of computing resources of multiple computers an example Google , Amazon , IBM. In this paper we have investigated cloud computing technology to know if it is useful for the Computer Labs of Taiz University, for this reason we have chosen to explore Cloud Computing in taiz university (CCIT) the objective is to study the different types of cloud-based computing to decide the appropriate type that would gain significant advantages for students and lecturers with the limited resources that are available.

## 2. Review of Related Literature

The paper focus on the significance of cloud computing as a solution to facilitate maintaining, learning, and teaching in laboratories at the lowest cost and time as possible, in addition, it will discuss the possible choices to

apply it in Maintenance Management to choose the appropriate solution with compliance of the administrators and Maintenance Management.

The literature review shows that researchers try to focus on the impacts of using cloud computing in enterprises and education fields. Several studies lead to focus more on the overall results. [3,4,5,6] The related literature studies categorized and concluded as follows: 1) cloud computing impact in Enterprises, 2) cloud computing in projects migration, 3) cloud computing in education.

### 3. Cloud Computing in Education

Cloud computing is a general term for delivering hosted services over the Internet. Google provides a service called Google Docs, a widely used example of cloud computing. [7]. Theory of Planned Behavior used to guide the research in examining what factors influence students to use Google Docs. [8] The researcher conducted both interviews and surveys to gain a better understanding of this phenomenon. The results derived from this research show that at the university level, students' intentions to use Google Docs are positively and significantly, the researches' findings can be used by multiple stakeholder groups to better understand the factors influencing the usage of Google Docs.

in [8] article presents the blended learning concept based on cloud computing paradigms and the manner it can be customized for higher and postgraduate education in engineering. Article starts from a functional analysis between traditional e-learning platforms and blended learning environments dedicated to higher and postgraduate education then it continues with the technological aspects and the deployment diagram of an e-learning cloud environment for engineering education. The article concluded that, the implementation of the interactive learning approach in individual study grants a high retention factor (up to 80%) and the collaborative learning develops the soft skills and teamwork capabilities. In other words, the hybrid class-ware approach implements the synchronous collaborative learning methodologies and allow the students to actively participate to the educational.

[9]. put forward and design college laboratory teaching management system based on hybrid cloud management function, and provide a good guide for colleges and universities to achieve cloud computing experimental teaching management.

The paper establishes the university experimental teaching management system based on hybrid cloud, realized the university experimental teaching platform construction and sharing of resources.

[10] concluded that there is significant difference in the attitude of computer usage between before and after using the environment of cloud computing service IT education for elementary school students. After using, the environment of IT education of cloud computing, students had more positive attitude toward it. There is a positive correlation between the using behavior and learning achievement for the IT education environment of cloud computing.

Several universities and research Institutes have developed number of cloud computing environments and supported tools example can be seen in Baker University School of Professional & Graduate Studies .

#### 3. Types of Cloud Computing

In the literature review of the could computing there are four basic cloud delivery models, as outlined by [11] which relate to who provides the cloud services. Companies and organizations may employ one model or a combination of different models in delivery of applications and business services, today there are four delivery models that companies and organizations are implementing for cloud Figure 1 shown four cloud computing models

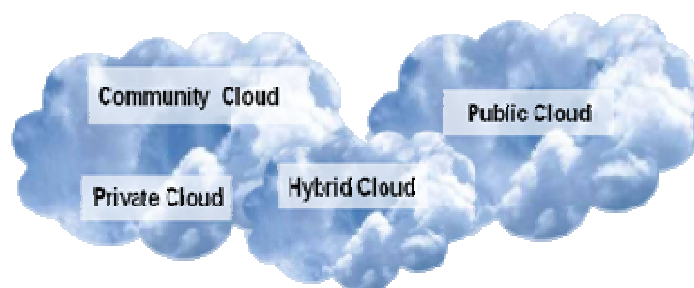

Figure 1 Shows the Four Cloud Computing Models

#### 1. Private Cloud or Internal

Cloud services only provided for an organization and managed by the organization or a third party. Private clouds are built to provide the IT activities/functions as a service, via an intranet, within the enterprise and

behind the firewall also this model is providing the control over data, security, and quality of service. The owners of this model have control over applications. Private clouds may be deployed in an enterprise datacenter, the key features of this model are: Scalability, rapid provisioning, chargeback ability, Widespread virtualization. Apply private cloud in Taiz university, students, employees and technicians can flexibly get access to virtual laboratories and materials from anywhere, e.g. their home PCs, laptop. This will reduce the burden of universities in investing laboratory facilities and staff. The advantages of a private cloud over enterprise IT include more cost effective datacenter management and higher levels of scalability. Private clouds are also more complicated to setup and more expensive to maintain than public clouds. Figure 2 shown the private cloud computing

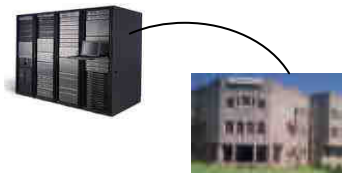

Figure 2 Private Cloud Computing

## 2. Public Cloud

IT activities/functions are provided “as a service,” over the Internet. The cloud infrastructure (data and applications) is owned and controlled by a third party which is an organization selling cloud services and it is available to the general public or a large industry group; that is, any user may access and use a public cloud. public cloud services can be Seen in figure 3.

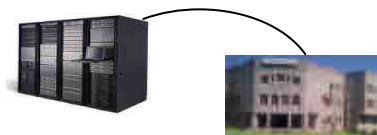

Figure 3 Public Cloud Computing

Public service cloud consists of storage service providers (free or charged) and web application for the public (for example: e-mail, Amazon Elastic Compute Cloud, Cloud Sun, IBM Blue Cloud, Google AppEngine or Windows Azure Services Platform).

Public Cloud has several key features such as: Scalability, Automatic/rapid provisioning, Standardized offerings, Consumption-based pricing and Multi-tenancy, in addition public cloud have several benefits such as: Easy and low cost infrastructure management, offers various tools for quick application deployment.

## 3. Hybrid Cloud

Hybrid clouds is Internal and external service delivery methods are integrated, with activities/functions allocated to based on security requirements and other established policies. It is also known as “virtual private clouds”. The cloud infrastructure is a composition of two or more clouds (private, community, or public) that remain unique entities but are bound together by standardized or proprietary technology that enables data and application portability (e.g., cloud bursting for load-balancing between clouds). Figure 4 represents the hybrid cloud infrastructure

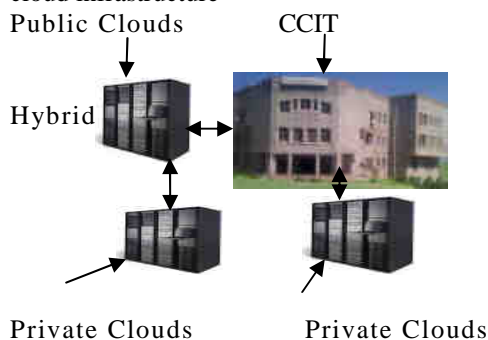

Figure 4 Hybrid Cloud Infrastructure

## 4. Community Cloud

Community cloud infrastructure is shared by several organizations and supports a specific community that has shared concerns (e.g., mission, security requirements, policy, and compliance considerations) where a company can use IaaS, PaaS and also customized SaaS for their business[12,13].

### 4. Private Cloud implementation

#### 1. Problem description

Taiz University (TU) has become one of the first Yemeni Universities to offer education and research programs to its local and regional academic institutions and industry. TU consists of eight faculties that award BSc, MSc, and PhD degrees in many disciplines, and number of students reached more than 24000 in 56 different academic disciplines. Computer Center and Information Technology (CCIT) was established to follow the recent technologies in information technology and in software engineering, it focus on adaptation the suite cloud computing technologies to make it easier to apply in the activities of the academic, administrative and community services. Due to the increasing number of students, and trainers, CCIT faces many obstacles during the work hour of labs. The IT technicians and the managers of CCIT summary the problem as follows:

- The training process is still performed in the traditional way and is not using the most recent technology and it does not correspond to the CCIT objectives.
- Operating systems and related software applications are installed and configured manually on each computer in laboratories and this process takes a lot of time and effort.
- Each course requires different environments (operating systems, libraries and software applications). Sometimes, they are incompatible and conflicting with each other.
- The number of maintenance resources such as CDs and DVDs are limited compared to the number of computers which yield to installation delays and course delay.
- The available hard disk space is not enough to store the required software and this lead to slow response of the devices.
- If a computer is crashed, IT technicians have to manually reinstall the software and this effect the students work in that time.
- Maintenance processes during the year cause expenditures that is about 4.26% of the total expenditures of CCIT.
- Frequent failures in the electricity cause delays followed by a burden of maintenance activities.

To solve the above mentioned problems we proposed a hybrid cloud computing model which consists of Ubuntu private cloud with Eucalyptus as a private side of the cloud, and Google Apps as a public side of the cloud. A short description of the contents of proposed model (hybrid cloud computing) is given as follows:

**2. Eucalyptus software:** (Elastic Utility Computing architecture for Linking the programs to useful systems) as in[14] Eucalyptus is a linux-based software architecture that implements scalable private and hybrid clouds within the existing IT infrastructure(hardware, storage, and network). It provides a virtual network overlay that both isolates network traffic of different users and allows two or more clusters to appear to belong to the same Local Area Network (LAN).

**3. Ubuntu Enterprise Cloud.** UEC for very summarized, is a stack of applications from Canonical included with Ubuntu Server Edition. UEC includes Eucalyptus along with a number of other open source software. UEC makes it very easy to install and configure the cloud. According to the Ubuntu enterprise documentation, Ubuntu private cloud with Eucalyptus is chosen for the implementation for several reasons:

- a) It is Open Source Software (OSS) so the security patches and version upgrades are free.
- b) Eucalyptus is suited to support private cloud solutions, and can be scale up.
- c) Ubuntu Server with Eucalyptus and other applications is easy to install and configure the cloud.
- d) Eucalyptus offers both computing and storage facilities.

All the mentioned reasons was behind the motivated of CCIT's maintenance Unit to create their own cloud computing infrastructure with nothing more than whatever commodity hardware they have available and that already runs Ubuntu Server.

CCIT laboratories are only open at scheduled class hours and not available for 24\*7. So out of the class hours access to laboratory facilities is limited or not possible.

As we know that cloud computing is useful in cases where the demands for computing resources are relatively small and stable. Such a situation reflects CCIT.

Therefore the CCIT’s management has to focus on the latest technologies for its activities by using the feasible benefits of cloud computing types.

#### 4. Implementation steps

The first step was to identify the data and applications within the CCIT laboratories that will be moved into the cloud. These data and applications are linked to three categories of activities as shown in table 1

Table 1. Data ,Applications and Roles of cloud service users activities in CCIT.

<p><b><u>Trainers (Teachers):</u></b>                  Develop lecture notes, lab manuals, and multimedia presentations.                  - Communicate with students.                  Prepare tests.</p>
<p><b><u>Students:</u></b>                  - Send feedback to trainers.                  - Communicate with students (forums).                  - Take the lectures and notes.                  - Send homework and projects.</p>
<p><b><u>Web Developers:</u></b>                  - Provide the training staff with software (email accounts, operating systems, productivity applications).                  - Use the development tools needed to write and host Web applications.                  - Install the applications and programs into the cloud image.                  - Insert the information about the cloud server such as the server name, IP address, administrator’s, remote power management, and the update of the default user name and password.</p>

The cloud users can be categorized to act with the appropriate cloud computing types. Figure 5 illustrates that student and trainers can use SaaS (software) by enabling service providers to give them the needed software. In addition they can use IaaS (infrastructure) to access the virtual machines, raw (block) storage, firewalls, load balancers, and networks are offered which will navigate to provide cloud based services to clients. On the other hand, the web developer can use PaaS (platform) to configure and maintain the operating systems, and to develop the applications platform such as Microsoft’s Visual Studio.Net to clients through internet service.

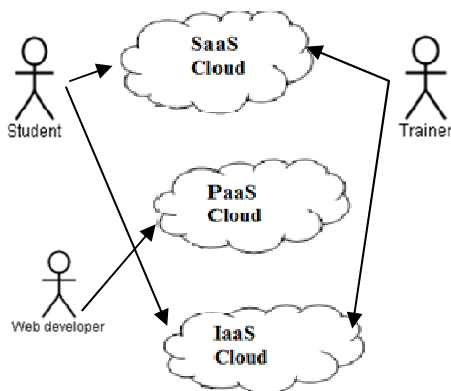

Figure 5. The main users of cloud services in CCIT.

## Processes of proposed

The main processes of the proposed solution are presented in figure 6. and are listed as follows:

1. The trainer prepares an application for the next lesson.
2. The web developer prepares a virtual machine image for the given applications. Only a single virtual machine image for each course is stored on the server.
3. The students have access to laboratory applications through virtual machines, instead of access to physical machines in laboratories.
4. Student and trainer get to the server and select the desired course. They have free choice to select suitable programming languages, for example, php, java, c++.
5. The server loads the image of the course from the image repository to a virtual machine on the server and runs that virtual machine for the student to do practice.
6. When a computer is crashed, the student neither has to wait for the laboratory manager to reinstall that computer nor move to another computer. The student just restarts the virtual machine, reloads the image to this virtual machine and runs it to continue his/her practicing.
7. Laboratory managers do not have to install and to configure software applications for every individual computer. Every time the software applications and their configurations for a course need to be changed, laboratory managers only need to modify or reconfigure the master virtual machine.

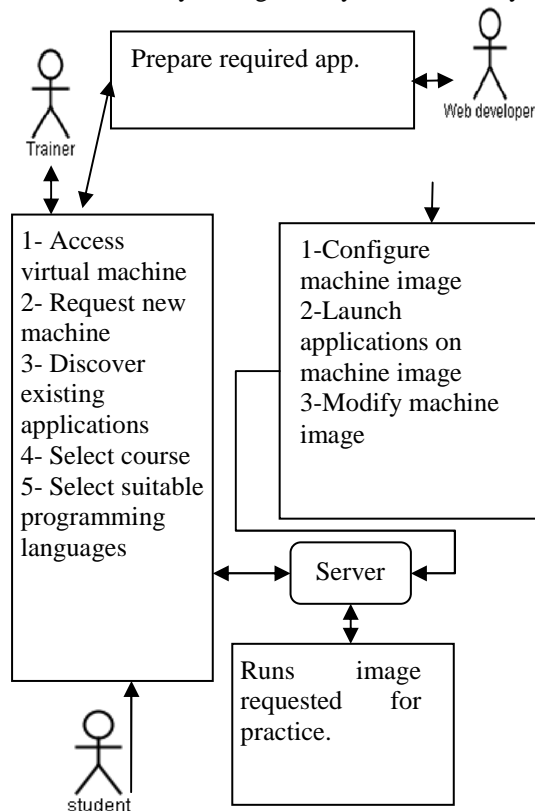

Figure 6. Processes of the Proposed Solution .

## 5. The proposed architecture

Detail and description of Ubuntu with Eucllyptus cloud architecture components such (Cloud Controller, Walrus Storage Controller, Cluster Controller, Storage Controller, Compute Node and Client machine) which we have adopted in this paper can be seen in [15] and figure 7 shown the proposed architectures. The proposed architecture is performed on two servers(SERVER 1,SERVER 2) and one client machine (CLIENT 1) as shown in figure 7.

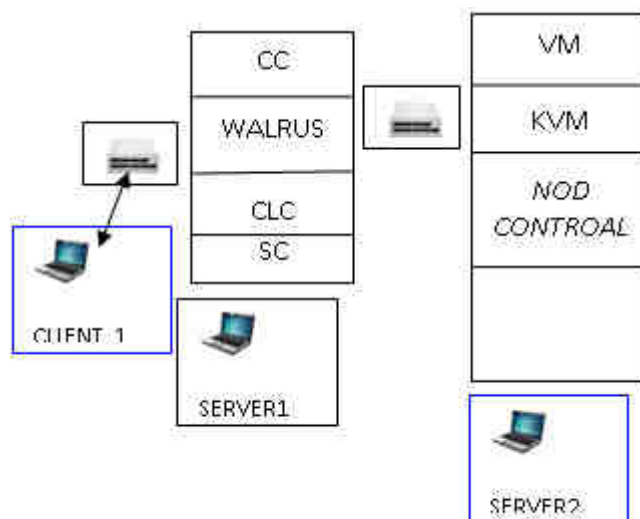

Figure 7. Proposed private Network connection.

The proposed cloud components have a private network via Ethernet network connectivity via switch layer 2.

- End-user requests to launch the instance via authentication interface on the client machine and to ensure that he/she Eucalyptus requires two sets of IP addresses. The first range is private, to be used only within the Eucalyptus system itself. The second range is public, to be routable to and from end-users and VM(Virtual Machine) instances. Both sets must be unique to Eucalyptus, not in use by other components or applications within the same network.
- The CLC (Cloud Controller) must have TCP/IP connectivity to all other Eucalyptus components.
- End-user typically interacts with Eucalyptus through a client interface through sending messages via TCP/IP to the machine on which the CLC (Cloud Controller) is deployed.
- End-user should has permission to get the session.
- Identification of CC(Cluster Controller) to take responsibility for deploying the instance and identification of the NC for running the instance.
- Downloading the image from WS3Walrus Storage Controller(SC) to NC images are cached so that starting multiple instances of the same machine image downloads that image only once.
- NC servers must be able to send messages to the Walrus server because images are downloaded by the NC using the Walrus URL. That is, the CLC does not need to be able to route network traffic directly to the NCs but Walrus is doing for the purposes of image delivery.
- Kernel-based Virtual Machine (KVM) is a virtualization solution for Linux on hardware that contains virtualization extensions. In Eucalyptus. KVM is chosen as preferred hypervisor. . KVM allowing multiple operating systems to run concurrently as VM on a host computer, hypervisor manages the execution of the operating systems of the virtual machines, called “instances”.
- Eucalyptus allows the running of instances from both Linux-based images and Windows-based images.
- The NC is running on each UEC node and is controlling the instances on the node. Cluster Controller(CC) gathers the data about physical resource availability on the node and their utilization, and the data about instances running on that node.

## 6. Cloud Computing Proposed requirements

UEC suggests hardware specification for a Eucalyptus Cloud Infrastructure as follows:

Hardware	Minimum	Suggested
CPU	1GHz	2 x 2GHz
Memory	2GB	4GB
Disk	5400rpm IDE	7200 rpm SATA
Disk Space	40GB	200GB
Networking	100Mbps	1000Mbps

Hardware	Minimum	Suggested
CPU	VT extensions	VT, 64-bit, Multicore
Memory	1GB	4GB
Disk	5400rpm IDE	7200rpm SATA or SCSI
Disk Space	40GB	100GB
Networking	100Mbps	1000Mbps

Hardware	Minimum	Suggested
CPU	VT extensions	VT, 64-bit, Multicore
Memory	1GB	2GB
Disk	5400rpm IDE	7200rpm SATA or SCSI
Disk Space	40GB	100GB
Networking	100Mbps	1000Mbps

## 7. Virtualize Computer Labs on a private cloud

To virtualize computer labs on a private cloud, a cloud developer must perform the following tasks:

Step 1: Prepare a private network which equipped with Layer 2 switches and connecting to servers with adequate hard drive space or networked data storages, so that the cloud clients can communicate with the cloud servers and storage devices.

Each machine should have one extra NIC for avoid network failure. hardware components).

Step 2: Installing and setting server 1.

Step 3: Installing and setting server 2.

Step 4: Installing Desktop version on the client machine and install KVM to help for install images on KVM platform and bundle them.

Step 5: Create custom Ubuntu machine image into CLC.

Step 6: Test the cloud workflow by running instance of custom image.

Step 7: The servers and data storage devices may generate heat during operation for that cooling system and uninterruptible power supply must be available.



### 8. Access cloud services workflow

Schema of the mapping workgroups in CCIT's labs is illustrated in figure 8. users groups are mapped in several sets, each set is mapped into one separate account with the ability that each group can be mapped into multiple accounts.

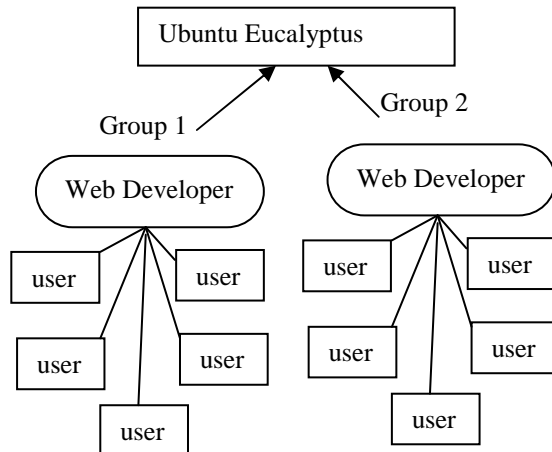

Figure 8. Mapping workgroups in CCIT labs.

For example web developer can log in to the Eucalyptus Administrator Console as the admin user. Admin user can add a new user to the Eucalyptus cloud through the following process: create a user, add user to a group and give user a login profile, admin user also, can create groups to share resource access authorizations among a set of users within an account.

Eucalyptus manages access to the cloud by policies attached to accounts, groups, and users each one of them has its own tasks, in addition to the tasks for credential management. Users can login into the cloud using one of the IP addresses assigned to the user by typing the CLC IP(Cloud Controller IP) in the web browser.

### 9. Public side

Google Apps is a web-based suite of programs provided by Google[16] also, it is available and free of charge to all schools and universities, for all those advantages the proposed model is illustrated in figure 9 the Google Docs

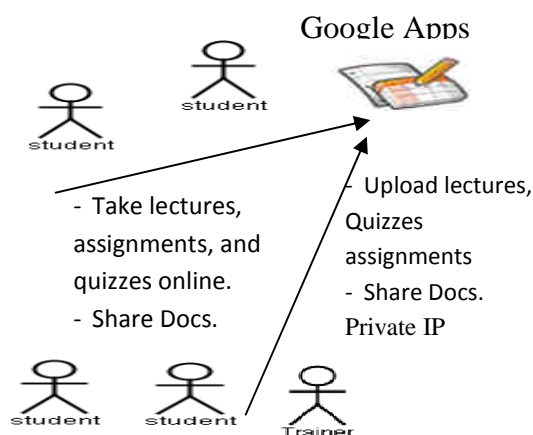

Figure 9. Google Docs usability's in CCIT.

usability's in CCIT domain name and can use Google Docs to allow users to do the following services :

- 1). Import existing documents, or create new ones from scratch.
- 2). Edit documents, spreadsheets and presentations from anywhere and anytime.
- 3). Share documents online and collaborate instantly.
- 4). Create an online form to do quizzes, and to collect data from others.
- 5). Collaborate on assignments.
- 6).Store documents secured online.

- 7). Eliminate confusing email attachments and version-control issues.
- 8). Save documents online for access at CCIT or at home.

## 9. Accessing Google Apps for CCIT

Users can access Google Apps for CCIT in several ways:

1. Through CCIT's website. There are several links to Google Apps from CCIT's website. For example, in the "Student services" drop-down menu student can click the links for "Gmail", "Google Docs", or "Google Calendar".
2. The Google Apps address will be available in CCIT's brochure. Users can directly access Google Apps directly using the web address.

As the result of adoption of Google Apps and Ubuntu cloud computing CCIT deliver high quality of services to their developers, students, and trainers, it not only allows the application developer to create Web based applications on CCIT's own infrastructure but also gain huge benefits as follows:

1. Easy access to the
2. programs using virtual machines (VM), and decreases maintenance efforts.
3. Maintaining costs will decrease proportional by the web developers.
4. Google Apps saves the provision of the amounts paid by the students to buy the lecture notes.
5. Students can retain their email addresses and continue to get access to the CCIT's work, stored
6. online in Google Docs, after graduation.
7. All of the Google Apps services can be accessed from anywhere via Internet connection. This reduces the need for flash drives.
8. There is no issue to have one version of a program at home and another version at CCIT.
9. Google Apps allows students to share documents and files with teachers and other students. So they can turn into assignments electronically and collaborate on projects with classmates.
10. The students can get their pre-prepared lectures notes and presentations using Google Docs which consists of the following programs: Google Documents, Google Presentations, Google Presentations.

## Conclusions

The hybrid cloud was designed to achieve the CCIT objectives to keep pace with current information technology, and to have a better control of the IT assets and configuration items in CCIT's IT environment. Exploration of the feasibility of implementing cloud computing at Tail University has been achieved and conclusion result is that cloud computing is feasible and worthwhile to implement and being part in education and research. Cloud computing will have significant impacts for managing the resources for taiz University in several areas such as daily education operations, supporting staff, and distributed management system can substantially reduce load, leveraging efficiencies. Students can work on the cloud, cooperate with their team members, share knowledge, and they can access their homework anywhere, at home or at CCIT.

## References

- [1]. P. Sharma " Grid Computing Vs. Cloud Computing" *International Journal of Information and Computation Technology*. ISSN 0974-2239 Volume 3, Number 6 (2013), pp. 577-582
- [2]. B. Kahanwal, T. Singh " The Distributed Computing Paradigms: P2P, Grid, Cluster, Cloud, and Jungle", *International Journal of Latest Research in Science and Technology* ISSN (Online):2278-5299 Vol.1, Issue 2 :Page No.183-187, July-August(2012),
- [3] A. Ampatzoglou, & I. Stamelos. (2010). Software engineering research for computer games: A systematic review. *Information and Software Technology*.
- [4] J. Chen, & H. Song. Industrial clusters' information based on SaaS model. Paper presented at the International Conference on Business Management and Electronic Information (BMEI), 13-15 May, 2011.
- [5] C. S. Chien, & J. Chien. Insight to Cloud Computing and Growing Impacts Information Computing and Applications (Vol. 105), Springer, pp. 250-257. 2010
- [6] T. Dillon, W. Chen, & E. Chang. Cloud Computing: Issues and Challenges. Paper presented at the 24th IEEE International Conference on Advanced Information Networking and Applications (AINA), 20-23 April, 2010.
- [7] M. Taylor, J. Haggert, D. Gresty, L. David, *Network Security* Volume 2011, Issue 3, March 2011, Pages 4-10
- [8]. IBM, "Google and IBM Announced University Initiative to Address Internet-Scale Computing Challenges," [http://www03.ibm.com/press/us/en/press\\_release/22414.wss](http://www03.ibm.com/press/us/en/press_release/22414.wss).
- [9]. B. Jeannette, R. Harvey, M. Martha and P. Terry Plum, Building a Virtual Archives and Preservation Curriculum Laboratory at Simmons College: A Case Study in Collaborative Construction

Journal of Education for Library and Information Science, Vol. 51, No. 4 ((Fall) October 2010), pp. 241-25.

[10]. E. Thomas, MAHMOOD, Zaigham and PUTTINI, Ricardo. Cloud Computing: Concepts, Technology & Architecture. Westford, Pearson Education 2013.

[11]. P. Mell. and T. Grance. "NIST Definition of Cloud Computing V15."

[12] Czernicki, "IaaS, PaaS, and SaaS Terms Clearly Explained and Defined."

<http://www.silverlighthack.com/post/2011/02/27/IaaS-PaaS-and-SaaS-Terms-Explained-and-Defined.aspx>, February 27, 2011.

[13] T. Behrend, E. Wiebe, J. London and E. Johnson. "Cloud Computing Adoption and Usage in Community Colleges", *Behaviour & Information Technology*, Volume 30, Issue 2, 2011, pp.231-240.

[14]. D. Nurmi, D. R. Wolski, C. Grzegorzczak, ... "The eucalyptus open-source cloud-computing system," in Proceedings of the 2009 9th IEEE/ACM International Symposium on Cluster Computing and the Grid, pp. 124–131, IEEE Computer Society, 2009.

[15]. Dr.G.R.Karpagam<sup>1</sup>, J.Parkavi<sup>2</sup>, Setting up of an Open Source based Private Cloud, IJCSI International Journal of Computer Science Issues, Vol. 8, Issue 3, No. 1, May 2011 ISSN (Online): 1694-0814, [www.IJCSI.org](http://www.IJCSI.org)

[16] Google "Getting to know Google Docs." <https://docs.google.com/support/bin/answer.py?hl=en&answer=49008&topic=15152>, February 2011.

The IISTE is a pioneer in the Open-Access hosting service and academic event management. The aim of the firm is Accelerating Global Knowledge Sharing.

More information about the firm can be found on the homepage:  
<http://www.iiste.org>

## CALL FOR JOURNAL PAPERS

There are more than 30 peer-reviewed academic journals hosted under the hosting platform.

**Prospective authors of journals can find the submission instruction on the following page:** <http://www.iiste.org/journals/> All the journals articles are available online to the readers all over the world without financial, legal, or technical barriers other than those inseparable from gaining access to the internet itself. Paper version of the journals is also available upon request of readers and authors.

## MORE RESOURCES

Book publication information: <http://www.iiste.org/book/>

## IISTE Knowledge Sharing Partners

EBSCO, Index Copernicus, Ulrich's Periodicals Directory, JournalTOCS, PKP Open Archives Harvester, Bielefeld Academic Search Engine, Elektronische Zeitschriftenbibliothek EZB, Open J-Gate, OCLC WorldCat, Universe Digital Library, NewJour, Google Scholar

