

Hover Control of an Underactuated Nonlinear Quadrotor Aerial Robot

Sakhi Rehman¹ Muhammad Umair Khan¹ Kifayat Ullah¹ Atiqur Rahman² LiaqatAli¹
1.Department of Electrical Engineering, University of Science and Technology Bannu, Pakistan
2.Department of Computer Science, Qurtaba University of Science and Information Technology D.I.Khan,
Pakistan

Abstract

Quadrotor aerial robot is an under actuated system with nonlinearities. It has 6 DOF with only four actuators. Actuators are the propellers with fixed pitch mounted on brushless DC motors. The actuators perform three basic operations for flight control of a quadrotor aerial robot; to generate lift force against gravity; to produce thrust force for flight in forward, backward, left and right directions against air drag; to balance weight at specific altitude during hover. Both translational and rotational motions of quadrotor aerial robot are controlled by varying relative propeller angular speed. The purpose of research work is to stabilize roll, pitch and yaw motions of a quadrotor during hover condition. To stabilize the system, an optimal model of quadrotor is presented. The model comprises of determining equations of motion of quadrotor, deriving the DC motor model and deriving the control inputs in terms of motor speeds. An optimal PD controller is designed, implemented in Simulink/Matlab and analyzed the performance of quadrotor in roll, pitch and yaw motions during hover.

Keywords: Hover, Under activated, Quadrotor, Aerial robot, PD controller.

1. Introduction and Problem Statement

An aerial vehicle is an air craft that is either controlled by auto pilots or remotely controlled from the ground. The aerial robots have complex behavior. They are autonomous such as to cope with the environmental changes. They have unique features to fly in almost all types of weather conditions. They have access to the places where human lives are in danger. The recent goal in research field of aerial robots is the ability to improve performance. Quadrotor aerial robot is an under actuated nonlinear system. Motion of quadrotor is controlled using the relative angular speeds of four contra-rotating propellers. The core issue of this research work is to get a stable hover for quadrotor. The main focus will be on the angular (roll, pitch and yaw) stability during hover. It is also necessary to get the altitude stability for stable hover, so altitude stability will also be considered. Newtonian method will be used to model the non-linear system of equations and it will be implemented in Matlab.

2. Literature Review

Many researchers have worked in the field of aerial robots with particular reference to quad rotor aerial robot. Some of the research work is discussed below.

[1] Bouabdallah and Siegwart (2007) have modeled a quadrotor platform known as OS4. The researchers studied the control aspects of the project by considering aerodynamic coefficient of the system. By simulating the control algorithm, fruitful results were acquired. An Integral Backstepping control algorithm has been adopted for controlling the complete behavior of the quadrotor such as attitude, position and altitude. Other parameters as hover, take off and landing and avoiding the obstacles autonomously have been presented.

[2] Bresciani et. al. (2008) focused on the quadrotor as to model the dynamics and evaluates the control algorithm. For the purpose, he developed a real plate form and simulated the system in 6 DOF simulations. For modeling of dynamic system, Newton-Euler formulism technique is used. In first stage only simulation of the quadrotor was carried out while on the second stage, the control approach was implemented on the platform.

[3] Flores (2012) designed a control model for tilt rotorcraft and experimentally implanted the model using hardware platform. The rotorcraft was able to cruise with high speed and hover like a helicopter. The control algorithm is based on Newtonian model which controls the transition between cruise mode and the hover state of the rotorcraft.

[4] Mary et al. (2010) designed a control algorithm for tracking and stabilization of a quadrotor helicopter using thrust, roll, pitch and yaw commands. The authors analyzed and identified the system using non-linear modeling. At a specific hover position, the model has been linearized through a Linear Quadratic Controller being implemented in simulation.

[5] Patkar et al. (2013) designed Micro Aerial Vehicle (MAV) having good maneuverability in the presence of atmospheric disturbances. A kinematic model has been designed using lift forces generated by rotors of an MAV, lift coefficient, roll, pitch and yaw movements caused by the variations in the rotor speeds and other basic operations of maneuvering. The research also analyzed the structural deflections of an MAV under different loading conditions.

[6] Rodic and Mester (2011) developed a model for outdoor autonomous quadrotor. The research is based on

developing a simulator for flight control. The authors modeled quadrotor kinematics, dynamics of rigid body, location of the position and navigation through different outdoor environment. The results have been shown for different maneuvers through simulation.

3. Mathematical Model of the System

The motion of a quadrotor aerial robot is considered as rigid body motion. The motion of a rigid body with 6 DOF can best be described using two reference frames.

- Earth inertial frame (E-frame)
- Body fixed frame (B-frame)

The Earth inertial frame and the Body fixed frame are as shown in figure 1.

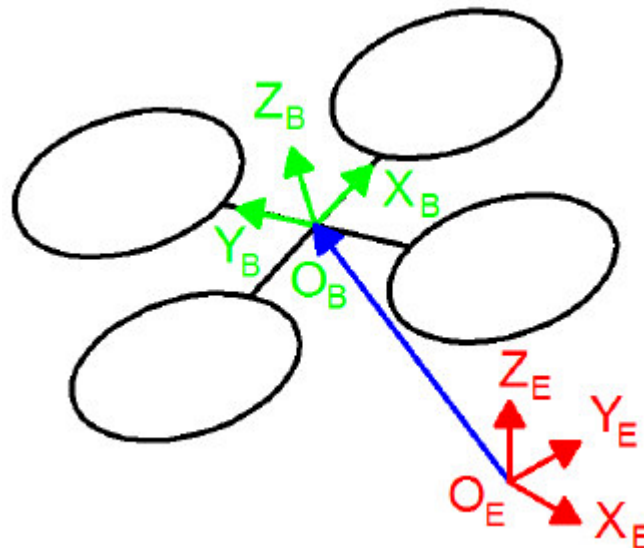

Figure 1 Reference Frames of a Quadrotor Aerial Robot

Earth inertial frame is shown as the right hand reference where X_E is pointing towards North, Y_E is pointing towards West, Z_E is pointing in upward direction with respect to earth and O_E is the E-frame origin. The Earth inertial frame is used to describe the linear and angular positions of a quadrotor aerial robot in a ground station.

Body fixed frame describes the orientation of a body of a quadrotor aerial robot. X_B is in the direction of a quadrotor front, Y_B is in the direction of a quadrotor left, Z_B is in the upward direction and O_B coincides at the origin of a quadrotor.

The quadrotor consists of four motors (DC brushless) with corresponding four propellers. First a best model of motor/propeller matching is obtained. In the second section, quadrotor model will be presented which include mathematical derivations for modeling the quadrotor parameters.

DC Motor Model

The dc motor model contains brushless dc motor system acting as an actuator in quadrotor system. The dc motor converts electrical energy into mechanical energy. The motor is supplied a dc voltage source.

DC motor consists of a stator and a rotor. Stator is a static part and fed by a DC voltage source. Rotor is a rotating part which rotates through the action of electromagnetic induction. DC motor consisted of a series resistor, an inductor and a voltage generator “e” (back emf of a rotor) as shown in figure 2.

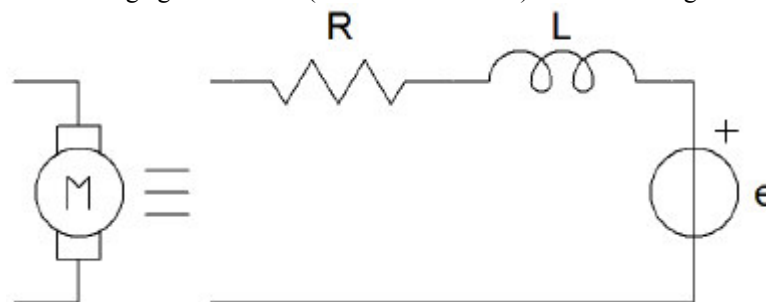

Figure 2 Motor model

Rotor voltage “e” and motor speed are directly related. Speed of the motor is controlled by a DC voltage source V. Circuit diagram is given by,

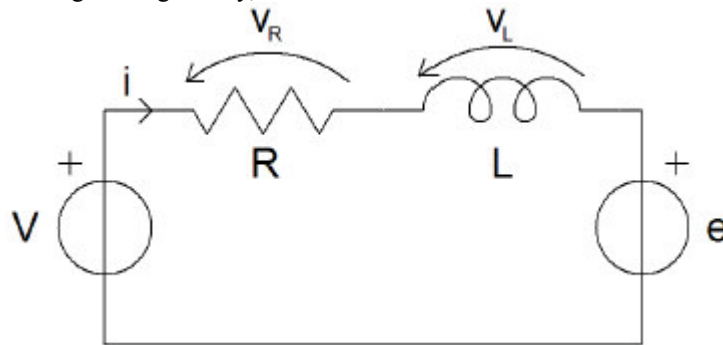

Figure 3 Motor circuit

Applying Kirchoff’s Voltage Law (KVL) to the circuit,

$$v = v_R + v_L + e \quad (1)$$

Where,

- v = applied voltage
- v_R = voltage across resistor
- v_L = voltage across inductor
- e = back emf

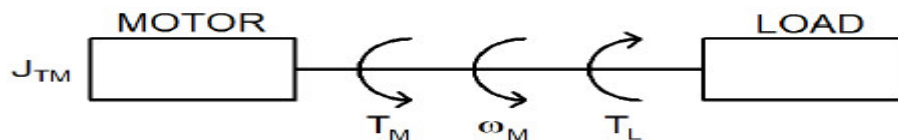

$$J_{TM} \dot{\omega}_M = T_M - T_L \quad (2)$$

Where,

- J_{TM} = total moment of inertia of motor
- $\dot{\omega}_M$ = angular acceleration of motor
- T_M = motor torque
- T_L = load torque

Rotor of DC motor is attached to propeller, it will exert torque. The relation of motor torque to motor speed is described by,

$$\Omega = (v - iR)K_v \quad (3)$$

$$Q_m = (i - i_o)/K_v \quad (4)$$

Where,

- Ω = Angular speed of motor
- v = Motor terminal voltage
- i = Motor current
- R = Motor resistance
- K_v = Motor speed constant
- Q_m = Motor torque
- i_o = Idle current

Whenever the rotor rotates it exerts mechanical power on the shaft. The relation between shaft power and motor speed is described by,

$$P_{shaft} = Q_m \Omega \quad (5)$$

$$P_{shaft} = (i - i_o)(v - iR) \quad (6)$$

Where,

- P_{shaft} = Shaft power

The relation between motor efficiency and motor speed is given by:

$$\eta_m = \left[1 - \frac{i_o R}{v - \frac{\Omega}{K_v}} \right] \frac{\Omega}{v K_v} \quad (7)$$

Where,

η_m = Motor efficiency

Thrust is the force exerted by the propellers on air in the downward direction. It is related to the motor speed by,

$$T = \frac{1}{2} \rho (\Omega R)^2 \pi R^2 C_T \quad (8)$$

Where,

T = Propeller thrust

ρ = Air density

C_T = Thrust coefficient

Propeller thrust is a result of the propeller torque. To find the relation between propeller torque and motor speed, the relationship is given by,

$$Q = \frac{1}{2} \rho (\Omega R)^2 \pi R^3 C_p \quad (9)$$

Where,

Q = Propeller torque

ρ = Air density

C_p = Power coefficient

Quadrotor Model

The orientation of a quadrotor is specified in three dimensional planes (x, y and z axes). The quadrotor has its linear position and angular position thus it has two types of motions, translational motion and rotational motion. Thus the orientation of a quadrotor is defined by its states in x, y and z axes. There are twelve states of a quadrotor, six of which are related to its linear positions (x, y, z) and rates of these positions ($\dot{x}, \dot{y}, \dot{z}$) in three dimensional plane while the other six states are related to angular positions (ϕ, θ, ψ) and their rates ($\dot{\phi}, \dot{\theta}, \dot{\psi}$). The state space vector of a quadrotor is given by,

$$X = [x \ \dot{x} \ y \ \dot{y} \ z \ \dot{z} \ \phi \ \dot{\phi} \ \theta \ \dot{\theta} \ \psi \ \dot{\psi}] \quad (10)$$

$$X = [x_1 \ x_2 \ x_3 \ x_4 \ x_5 \ x_6 \ x_7 \ x_8 \ x_9 \ x_{10} \ x_{11} \ x_{12}] \quad (11)$$

$$\left\{ \begin{array}{l} x_1 = x \quad x_5 = z \quad x_9 = \theta \\ x_2 = \dot{x} \quad x_6 = \dot{z} \quad x_{10} = \dot{\theta} \\ x_3 = y \quad x_7 = \phi \quad x_{11} = \psi \\ x_4 = \dot{y} \quad x_8 = \dot{\phi} \quad x_{12} = \dot{\psi} \end{array} \right\} \quad (12)$$

Control Inputs

The control of a quadrotor is totally based on the motion control of the four propellers attached to brushless dc motors. Generally the angular speed of a motor is represented by a symbol omega “ Ω ” and measured in radians per second. Thus the angular speeds of the four motors M_1, M_2, M_3 and M_4 mounted at the end of each arm are $\Omega_1, \Omega_2, \Omega_3$ and Ω_4 respectively. Relative variations in angular speeds of the motors give rise to control inputs.

Based on the pattern of variations in angular speeds, there are four basic control inputs to a quadrotor. The control vector for a quadrotor is given by:

$$U = [U_1 \ U_2 \ U_3 \ U_4] \quad (13)$$

$$U_1 = \frac{mg + k_{pz}(z_d - z) + k_{dz}(-\dot{z})}{\cos\theta \cos\phi} \quad (14)$$

$$U_2 = k_{pp}(\phi_d - \phi) + k_{dp}(-\dot{\phi}) \quad (15)$$

$$U_3 = k_{pt}(\theta_d - \theta) + k_{dt}(-\dot{\theta}) \quad (16)$$

$$U_4 = k_{pps}(\psi_d - \psi) + k_{dps}(-\dot{\psi}) \quad (17)$$

Where,

k_{pz} and k_{dz} = Controller gains for altitude control

k_{pp} and k_{dp} = Controller gains for roll angle control

k_{pt} and k_{dt} = Controller gains for pitch angle control

k_{pps} and k_{dps} = Controller gains for yaw angle control

z_d , ϕ_d , θ_d and ψ_d are the desired values of altitude, roll angle, pitch angle and yaw angle.

In terms of angular speeds of a quadrotor the control inputs are given by:

$$U_1 = b(\Omega_1^2 + \Omega_2^2 + \Omega_3^2 + \Omega_4^2) \quad (18)$$

$$U_2 = b(-\Omega_2^2 + \Omega_4^2) \quad (19)$$

$$U_3 = b(\Omega_1^2 - \Omega_3^2) \quad (20)$$

$$U_4 = d(-\Omega_1^2 + \Omega_2^2 - \Omega_3^2 + \Omega_4^2) \quad (21)$$

Where 'b' is the thrust factor and 'd' is the drag factor.

The linear acceleration along x-axis, y-axis and z-axis and the angular acceleration about x-axis, y-axis and z-axis are given by,

$$\ddot{X} = (\sin\psi \sin\phi + \cos\psi \sin\theta \cos\phi) \frac{U_x}{m} \quad (22)$$

$$\ddot{Y} = (-\cos\psi \sin\phi + \sin\psi \sin\theta \cos\phi) \frac{U_x}{m} \quad (23)$$

$$\ddot{Z} = -g + (\cos\theta \cos\phi) \frac{U_x}{m} \quad (24)$$

$$\ddot{\phi} = \frac{I_{yy} - I_{zz}}{I_{xx}} \dot{\theta} \dot{\psi} - \frac{I_{TP}}{I_{xx}} \dot{\theta} \Omega + \frac{U_x}{I_{xx}} \quad (25)$$

$$\ddot{\theta} = \frac{I_{zz} - I_{xx}}{I_{yy}} \dot{\phi} \dot{\psi} + \frac{I_{TP}}{I_{yy}} \dot{\phi} \Omega + \frac{U_x}{I_{yy}} \quad (26)$$

$$\ddot{\psi} = \frac{I_{xx} - I_{yy}}{I_{zz}} \dot{\phi} \dot{\theta} + \frac{U_x}{I_{zz}} \quad (27)$$

Where,

I_{xx} = the moment of inertia along x-axis

I_{yy} = the moment of inertia along y-axis

I_{zz} = the moment of inertia along z-axis

m = the mass in kg of a quadrotor

Angular speed ' Ω '

The angular speed generates different types of motions of a quadrotor. It is measured in radians per second.

$$\left\{ \begin{array}{l} \Omega_1 = \left[\frac{1}{4b} U_1 + \frac{1}{2b} U_3 - \frac{1}{4d} U_4 \right]^{\frac{1}{2}} \\ \Omega_2 = \left[\frac{1}{4b} U_1 - \frac{1}{2b} U_2 + \frac{1}{4d} U_4 \right]^{\frac{1}{2}} \\ \Omega_3 = \left[\frac{1}{4b} U_1 - \frac{1}{2b} U_3 - \frac{1}{4d} U_4 \right]^{\frac{1}{2}} \\ \Omega_4 = \left[\frac{1}{4b} U_1 + \frac{1}{2b} U_2 + \frac{1}{4d} U_4 \right]^{\frac{1}{2}} \end{array} \right. \quad (28)$$

4. Simulation Results

The behavior of a quadrotor aerial robot can best be tested by successfully implementing the controller using Matlab. It is necessary to get the accurate results of both altitude and attitude. Altitude is simply the vertical distance which the quadrotor will cover and necessarily becomes stable. Attitude is the behavior of a quadrotor during their rotational motions, which are roll, pitch and yaw. In order to test the behavior of a quadrotor, simulation results for both altitude and attitude are presented while implementing the mathematical model using Matlab.

Thrust is the force exerted by the propellers on air in the downward direction.

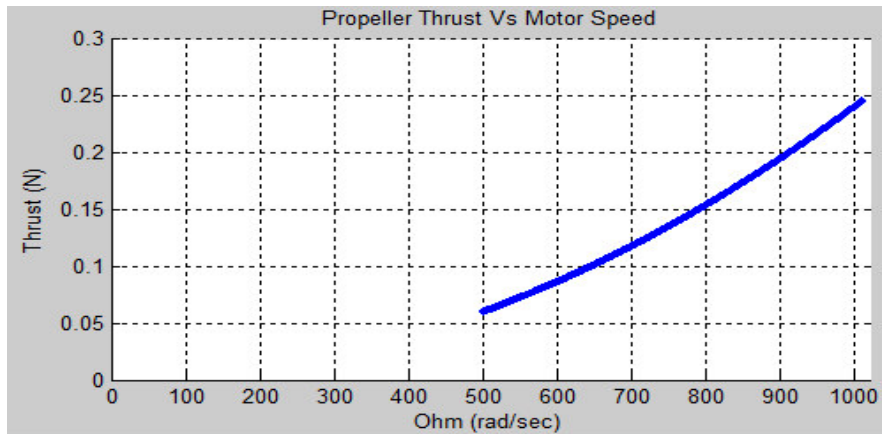

Figure 4 Simulation results of Thrust Vs Motor Speed

Initially the altitude of the quadrotor is set to zero. The desired altitude is 10 meters. The controller is set to respond at time $t=0$. For this reference signal, the controller shows 2.9% overshoot and then becomes settling down to the desired value as shown in figure 5.

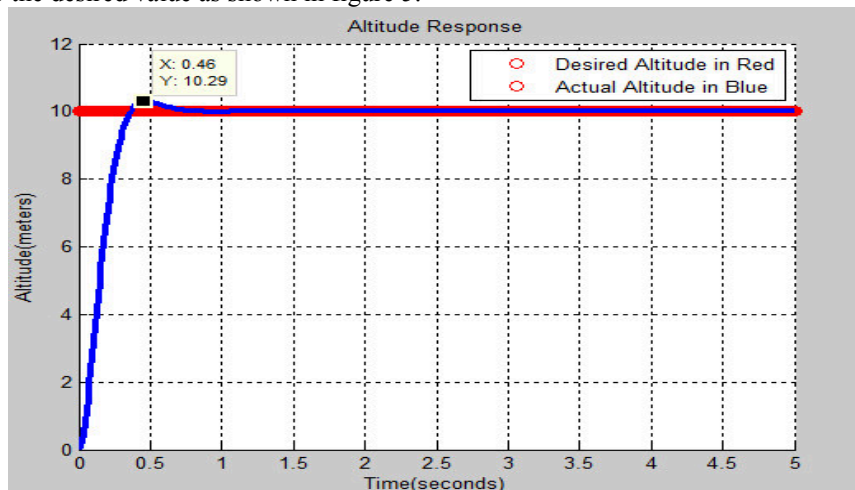

Figure 5 Simulation result for altitude controller

In most of the situations, it is advisable to avoid overshoots and slower response is not problematic. Thus the parameters of the controller are adjusted such that the overshoots are eliminated as shown in figure 6.

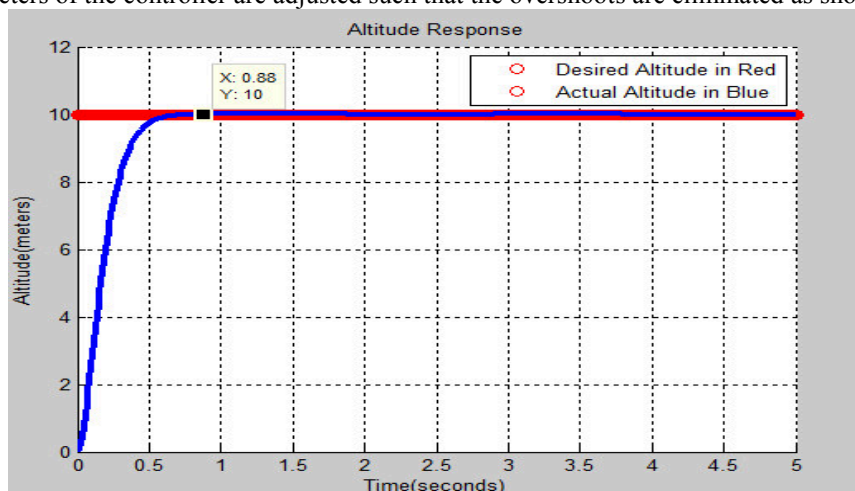

Figure 6 Simulation result for altitude controller

It is clear from the figure 7 that it takes some considerable time to reach the desired signal. Thus an error response of the controller is plotted in figure 6.

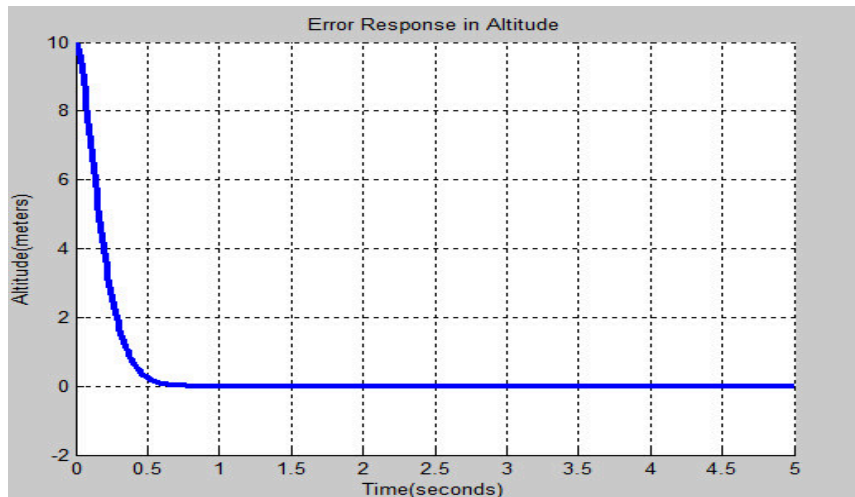

Figure 7 Simulation result for error in altitude

Attitude Response

In order to get the attitude response of a quadrotor, three different states of a quadrotor aerial robot must be considered. These states are the roll, pitch and yaw angles. The response of a controller for each state is separately described.

Roll Angle Response

Roll angle is formed through rotation of a quadrotor about the longitudinal axis. Its initial value is set to 1.04 ($\pi/3$) radians and the desired roll angle is 3.14 (π) radians. The controller is set to respond at time $t=1$ sec as shown in figure 8.

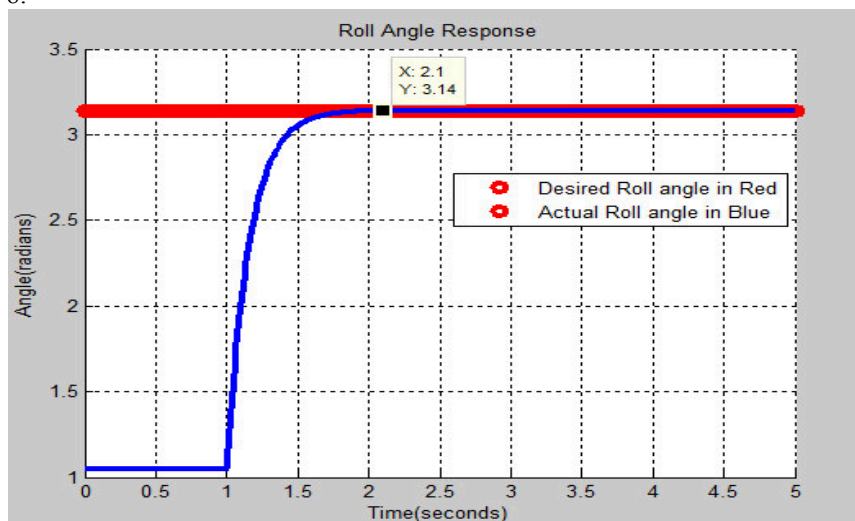

Figure 8 Simulation result for roll angle

Pitch Angle Response

Pitch angle is the angular displacement of a quadrotor about lateral axis. Its initial value is set to 1.57 ($\pi/2$) radians and the desired pitch angle is -1.57 ($-\pi/2$) radians. The controller responds at time $t=0.5$ sec as shown in figure 9.

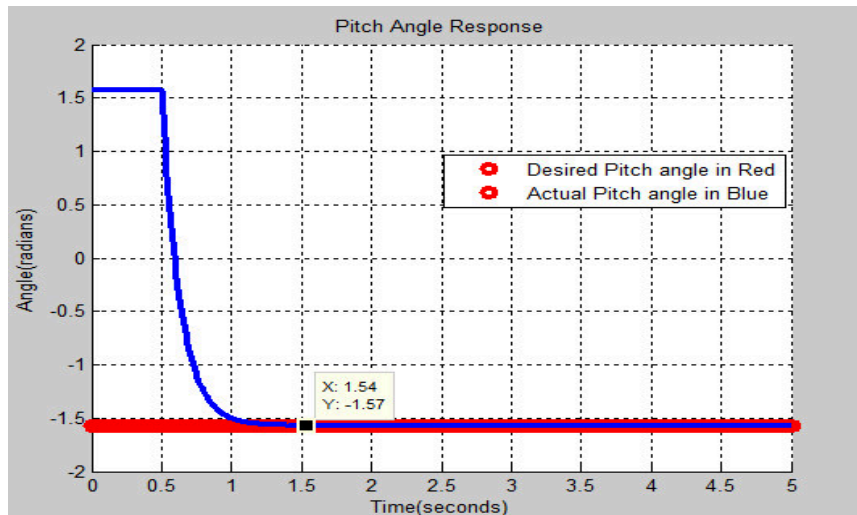

Figure 9 Simulation result for pitch angle

Yaw Angle Response

The rotation of a quadrotor about vertical axis gives rise to a yaw angle. The initial value for the yaw angle is chosen to be $0.628 (\pi/5)$ radians and the reference value is $6.28 (2\pi)$ radians. The controller response is shown in figure 10 at time $t=2$ sec.

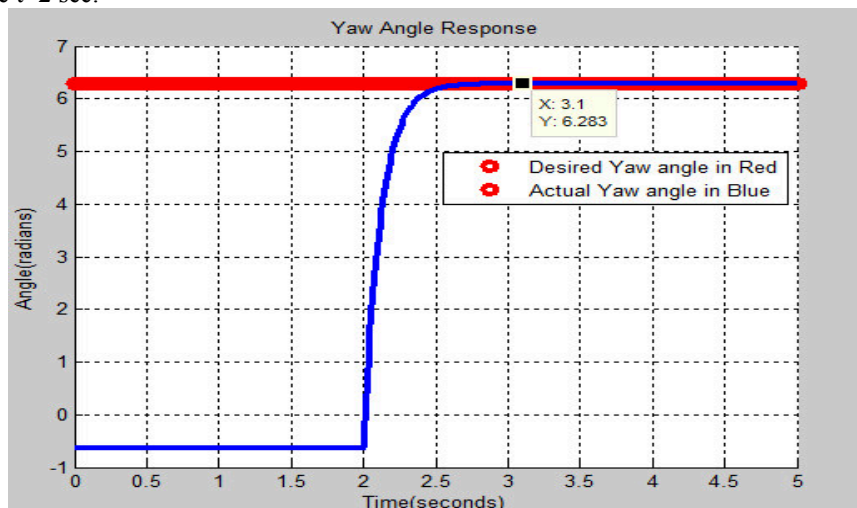

Figure 10 Simulation result for yaw angle

The error response of the controller for roll, pitch and yaw angle is shown combined in figure 11.

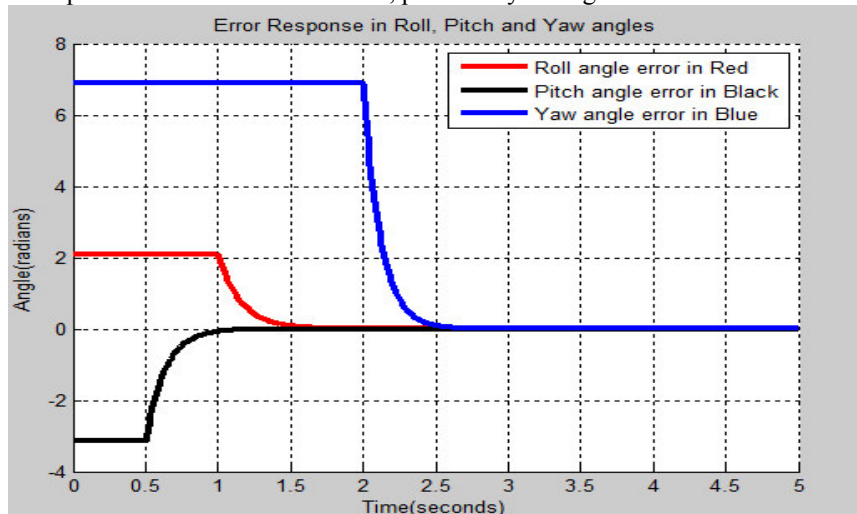

Figure 11 Simulation result for error in roll, pitch and yaw angles

It is clear from the plots that after a finite time the steady state errors in both altitude and attitude are settled to zero and the system becomes stable.

5. Conclusion

The main purpose of this project is to design a stable hover for a quadrotor. As the quadrotor system is highly nonlinear, so there are mechanical vibrations during the hover state of a quadrotor. In order to minimize these mechanical vibrations and get a stable system, a dynamic model for stable hover of a quadrotor is presented. The model is suitable and coped with the control and stability of the system. It is composed of a quadrotor model. The dc motor is analyzed using mathematical modeling techniques while the quadrotor is analyzed through modeling the aerodynamic forces and relative equations of motions. The control inputs are derived using the angular speeds of the motors. The core objective is to analyze the aerodynamic behavior of the quadrotor and diminish the mechanical vibrations through design of an optimal controller.

References

1. Bouabdallah, S. and R. Siegwart. 2007. Full Control of a Quadrotor. International Conference on Intelligent Robots and Systems, Zurich, Switzerland.
2. Bresciani, T., D. Caltabiano and R. Sannino. 2008. Modelling, Identification and Control of a Quadrotor Helicopter. ISSN 0280-5316 ISRN LUTFD2/TFRT-5823-SE.
3. Flores, G. R., J. Escareño, R. Lozano and S. Salazar. 2012. Quad-Tilting Rotor Convertible MAV: Modeling and Real-Time Hover Flight Control. *J Intell Robot Syst*, 65:457–471.
4. Mary, C., L. C. Totu, S. K. Koldbak and Flemming. 2010. Modelling and Control of Autonomous Quad-Rotor. Department of Electronic Systems AALBORG University.
5. Patkar, U., S. Datta, S. Majumder, D. Ray, S Char and M. Majumder. 2013. Studies on effect of basic maneuvering operations on quadcopters thrust generated. 2013 International Conference on Robotics, Biomimetics, Intelligent Computational Systems (ROBIONETICS) Yogyakarta, Indonesia, November 25-27.
6. Rodic, A. and G. Mester. 2011. The Modeling and Simulation of an Autonomous Quad-Rotor Microcopter in a Virtual Outdoor Scenario. *Acta Polytechnica Hungarica* Vol. 8, No. 4. 107-122.