

# Design Build Lung Sound Detection with Fast Fourier Transform (FFT) Analysis in Normal and Smoker Subjects

Endang Dian S

Department of Electromedical Engineering, Health Polytechnic of Surabaya, Indonesia

Sumber

Department of Electromedical Engineering, Health Polytechnic of Surabaya, Indonesia

## Abstract

Smoking disturbs health, this is a fact we can not avoid. Many diseases have been shown to be a bad result of smoking, either directly or indirectly. Even the World Health Organization (WHO) has warned that in the decade 2020-2030 tobacco will kill 10 million people per year, 70% of which occur in developing countries. Through the 1983 resolution, the World Health Organization (WHO) has established May 31st as World Tobacco Free Day every year. The output of this research is to design an instrument booster for lung sound detection and analyze lung noise by using FFT method on smokers and nonsmokers subject. In the signal of the smoker respondent shows with the same amplitude of its height with regular period, so the amplitude is 5mvp-p. After our signal analysis using FFT method the lung voice signal shows the same amplitude, At the same frequency between 0.5 Hz amplitude 5.8 mV. In non smoker respondents the signal shows with the same amplitude of its altitude with regular period, so the amplitude is 6mvp-p. After our signal analysis using the FFT method the lung voice signal shows different amplitude. At the same frequency between 0.5 Hz the amplitude is 11 mV.

**Keywords:** FFT, Lung Sound, Smokers and Non Smokers Respondents

## 1. INTRODUCTION

Smoking disturbs health; this is a fact we can not avoid. Many diseases have been shown to be a bad result of smoking, either directly or indirectly. Recent research also shows the dangers of secondhand smoke, which is smoke inhaled by non-smokers because it is around smokers, or commonly referred to as passive smokers (Aji gunawan, 2013). According to research Pramitra Joko R (2012) about the acquisition of lung sounds with auscultation techniques that only distinguish the state of normal and abnormal lungs. The problem that arises is the sound of the lungs occupying a fairly low frequency of about 20 - 400 Hz. one of the components that can be taken from the lung sound signal is the frequency spectrum and then transformed into the frequency domain using FFT then the pulmonary voice signal can be recognized characteristic of the signal. So the study still lacks the clarity on the description.

Lung sound recording was obtained using a modified stethoscope using condenser Mic. data subject retrieval was in boys and girls of each measurement in the bronchovesicular region, right chest. In research conducted by Dyah Titisari research (2013) only removes the sound of jantung on lung sound recording does not discuss about certain disorders in the lungs. Endah Budiasih research (2011) is developing an electronic stethoscope that can menghilangkan noise - noise that occurs so that the sound data obtained more clearly, but the study has not discussed the pattern recognition for lung sounds.

Based on the research - research that has been done previously it is necessary to study lung sound analysis on the subject of smokers and non smokers with the research title "Design Build Lung Sound Detection With Fast Fourier Transform Analysis (FFT) On Normal Subjects and Smokers"

The purpose of this study was to detect lung sounds with normal subjects and smokers using FFT method, to find out how much the frequency spectrum value in normal subjects and smokers.

## 2. RESEARCH METHOD

This research was experimental research that was conducted in the field with the design of posttest only control group. The subject of this research was comparison of lung sound detection. The procedure of this research was compare lung sound detection with Fast Fourier Transform analysis (FFT) on normal subjects and smokers. The data was processed descriptively.

## 3. RESULT AND DISCUSSION

### Lung

Our bodies depend on the respiratory system to live, respiratory assessment contains an important aspect in evaluating health. The respiratory system primarily serves to maintain the exchange of oxygen and carbon dioxide in the lungs and tissues and to regulate acid-base balance. Any changes in this system will affect other body systems. In the respiratory system especially in the lungs. Examination can be done to determine the condition of the lung by examination such as inspection, palpation, percussion, and auscultation.

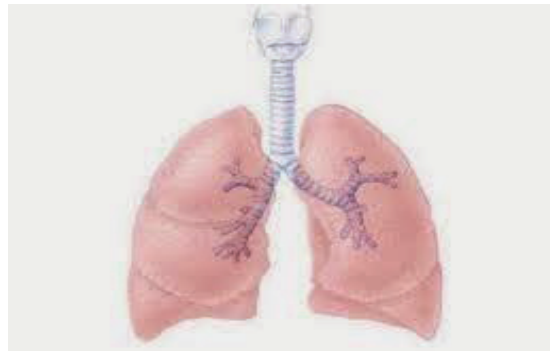

Figure 1 Lungs

### Stethoscope

The direct auscultation method was until 1816 when he was examining a girl with general symptoms of heart disease. Because the patient is fat, young, and female, he feels that the usual method of examination is inappropriate. However, he recalls that if one end of a piece of wood is scratched with a needle, the sounds that arise will be able to be heard clearly if the other end of the wood is taped to the ear.



Figure 2 Stethoscope

### Mic Condenser

Condenser mic is an electronic component that stores energy in the electrostatic field, this type of microphone is also a transducer that uses the basic materials of a capacitor that converts acoustic energy into electrical energy. This type of microphone is widely used for both live and recording purposes.



Figure 3 Sensor Mix Condenser

In the operation of the condenser mic, this type of mic requires a suber battery or an external phantom power source in order for the microphone to operate. That is, this mic must use the amplifier or preamp before plugged into amps or other tools. The use of mic condenser requires the consumption of electric power, the power can come from batteries placed in the mic (must be replaced if the battery runs) or from external power (up to 48 V, which is routed via a microphone cable).

### High pass filter

High pass filter is a type of filter that passes high frequency, but reduces the frequency amplitude lower than the cutoff frequency. The value of the reduction for the frequency varies for each of these filters. The high pass filter is the opposite of the low pass filter, and the band pass filter is a combination of high pass filter and low pass filter.

This filter is very useful as a filter that can block unwanted low frequency components from a complex signal as it passes the highest frequency. The simplest high pass filter consists of a capacitor connected in parallel with the resistor.

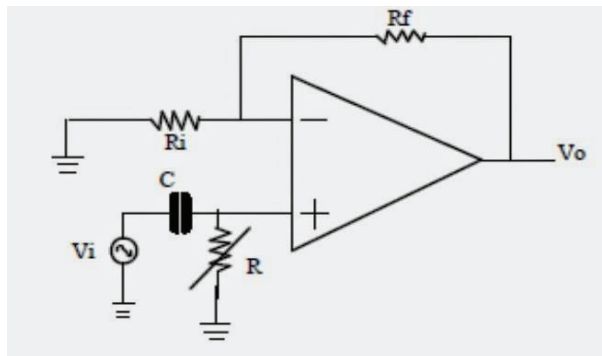

Figure 4 High Pass Filter second order (-40dB)

### Fast Fourier Transform (FFT)

J. W. Cooley and J. W. Tukey (W. Tukey, 1965), successfully formulated an efficient Fourier Transform algorithm calculation technique. The technique of computing this algorithm is known as Fast Fourier Transform or more popularly known as FFT which was introduced by J.S. Bendat and A.G. Piersol in 1986. Fast Fourier Transform in Indonesian is Fast Fourier Transformation is the source of an algorithm to calculate. Discrete Fourier Transform (fast transformation of DFT diskriers) quickly, efficiently and inversely. Fast Fourier Transform (FFT) is applied in various fields of digital signal processing and solving partial differential equations into algorithms for multiplying large numbers of integers. There is also a basic class of FFT algorithms that are decimation in time (DIT) and decimation in frequency (DIF). The outline of the word Fast is interpreted because the FFT formulation is much faster than the previous Fourier Transform algorithm. The FFT method requires about 10000 mathematical algorithm operations for data with 1000 observations, 100 times faster than the previous method. FFT discovery and personal computer development, FFT techniques in the process of data analysis became popular, and is one of the standard methods in data analysis. A common form of transformation used to convert signals from time domain to frequency domain is Fourier transform: The equation of the sinya  $x(t)$ .

$$X(\omega) = \int_{-\infty}^{\infty} x(t) e^{-j\omega t} dt$$

FFT in gesture processing include Period and frequency :

1. Period In general the period is defined as the time required for a signal or wave to reach a full wave. And can determine the value of perodesitasnya. It should be noted that this notion applies to monochromatic cues, the signal in question is a single wave, must have a priode. Thus the signal is known as priodis, the observation can be done by monitoring the wave we can know the value contained in the cues and periods.
2. Frequency There is a period, then there is a frequency defined as the number of waves that occur in 1 second. Frequency is defined simply as the opposite of time. So the time that the units are seconds (second) will be Hertz (1-per second) will only have exactly one spectral value. Which is known as the frequency spectrum. This sense of frequency also applies to monochromatic waves.

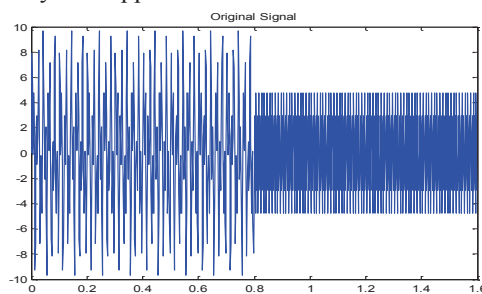

Figure 5 Signal source in time domain

## Pre Amplifier Circuit

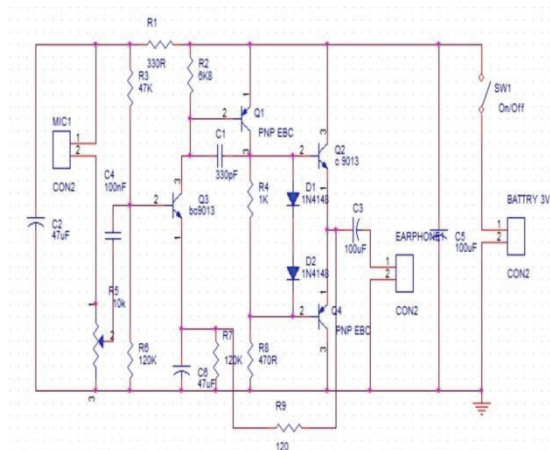

Figure 6 Pre Amplifier circuit

The Pre Amplifier circuit is the first amplifier circuit of the condenser mic. The purpose of this circuit is used as a signal modifier of the sound input of the mic condenser inside the stethoscope. In this Pre Amp circuit the signal is boosted by 5 times so that the output of sinyal is not too big and can be read through PC soundcard.

### The output image of each block

#### 1. Output of Pre-Amp Circuit

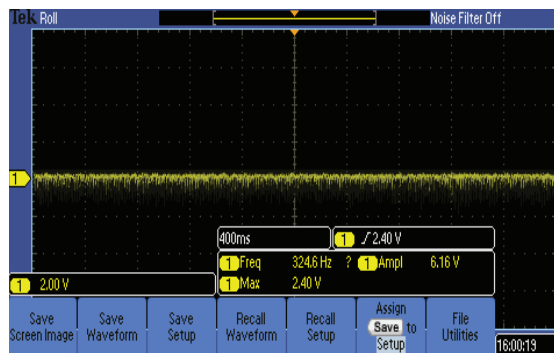

Figure 7 Output Pre-Amp

#### 2. Output Filter Series (Low Pass Filter)

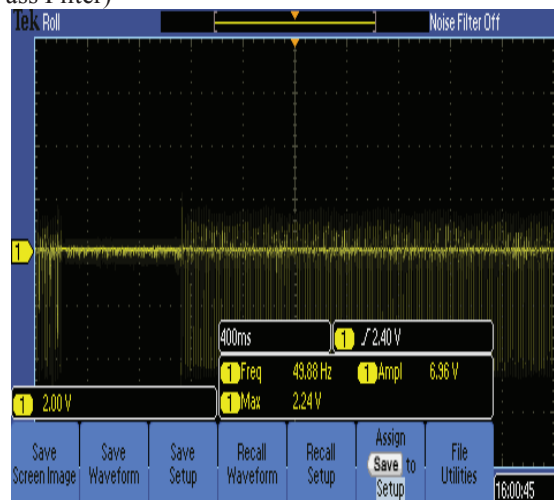

Figure 8 Output of LPF

### 3. Output Filter Series (High Pass Filter)

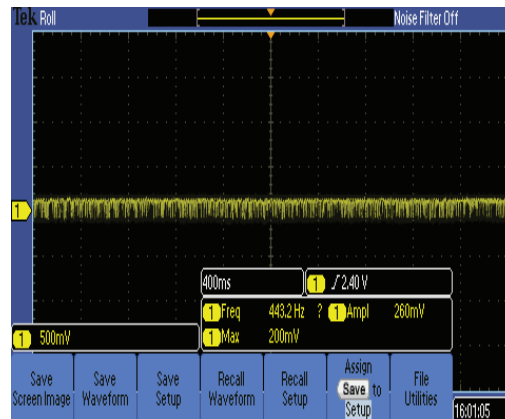

Figure 9 HPF output

Data of First Respondents Non Smokers Pulmonary lung signal on smokers and non smokers respondents are taken for analysis. Non smoker respondents data were analyzed using Fast Fourier transform method. Fast Fourier Transform (FFT) method is used to know the spectrum of signal to be analyzed. Changes in signal form between smokers and non smokers will be known to differ by looking at the signal spectrum. The highest amplitude value will be seen to know the value of frequency which will be used to know the difference between lung noise of smoker and non smoker.

Pulmonary lung signal in the first non smoker respondents is shown in Figure 10 amplitude indicates lung sounds that tend to have the same amplitude. There is no decrease in amplitude in the lungs.

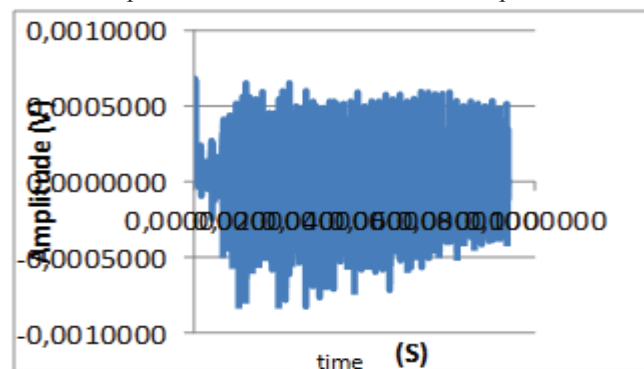

Figure 10 lung respondent noise signal non smoker

Pulmonary lung signal in the non smoker male respondent shows signal with equal amplitude of height and regular period. Amplitude of pulmonary signals in non-smoker men is 6 mVp-p. Figure 11 shows the pulse signals.

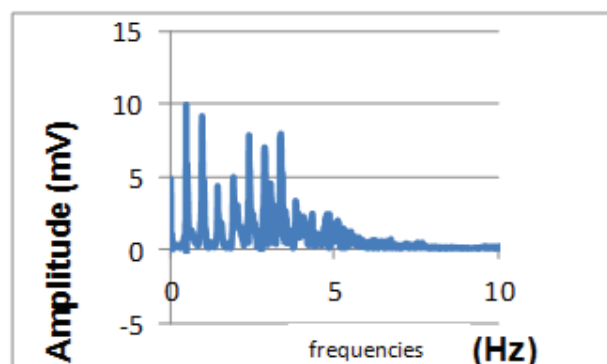

Figure 11 The first lung respondent's lung signal is non smoker

In the first respondent non-smoker men were analyzed using FFT. The pulmonary sound signal indicates a frequency between 0-5 Hz. The highest amplitude is at a value of 10 mV at a frequency of 0.8 Hz. the second largest amplitude appears after the main frequency with a height of 9mV at a frequency of 1 Hz.

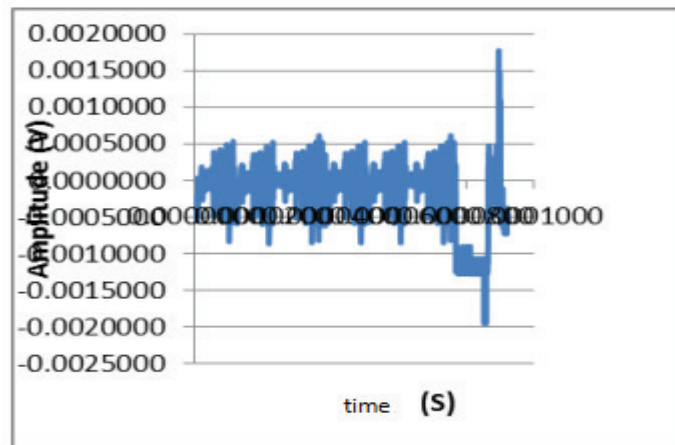

Figure 12 The first lung respondent's lung smoke signal

Pulmonary lung signals in the first male smoker respondent exhibit signals with equal amplitude of altitude and regular periods. Amplitude of pulmonary signals in non-smoker men is 5mVp-p. Figure 13 shows the pulse signals.

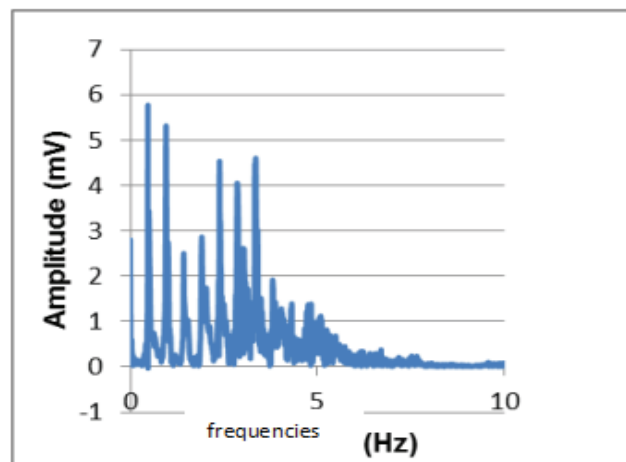

Figure 13 First lung lung respondents' signals are smokers

In the first respondents male smokers were analyzed using FFT. The pulmonary sound signal indicates a frequency between 0-5 Hz. The highest amplitude is at 5.8 mV at a frequency of 0.8 Hz. the second largest amplitude appears after the main frequency with a height of 5.5 mV at a frequency of 1 Hz

**Data of Respondents of both Signals of Smokers (5 years and above)**

The lung pulmonary signal in the respondents of both smokers is shown in Figure 13. The amplitude shows the lung noise which tends to have the same amplitude. It can decrease the amplitude in the lung sound.

**3. CONCLUSION**

In the smoker respondent signal indicates with the same amplitude of its altitude with regular period, so the amplitude is 5mvp-p. After our signal analysis using the FFT method the lung voice signal shows the same amplitude, At the same frequency between 0.5 Hz shows the amplitude of 5.8 mV. In the non smoker respondent shows the signal with the same amplitude of its altitude with regular period, so the amplitude is 6mvp-p. After our signal analysis by using FFT method the lung voice signal shows different amplitude, At the same frequency between 0.5 Hz shows the amplitude of 11 mV.

**4. SUGGESTION**

1. Group of respondents can be increased division of age group to know lung voice - lung between responder age responder.
2. More improved on hadwere due to its components using local components. In terms of already visible differences.

**REFERENCES**

Acmah Rizal ,Sogirjardjo Soegijoko ( 2006 ) , Stetoskop Elektronik Sederhana Berbasis PC dengan fasilitas

- Pnegolahan Sinyal untuk Auskultasi jantung dan paru Teknik Biomedik Bandung .  
Amos Henry Ronald, (<http://gloriaentertainment.blogspot.co.id/2011/09/mikropon-kondensor.html>)  
Dyah Titisari, Indah Soesanti , Bondhan Winduratna ( 2013 ) Reduksi Suara Jantung Dari Instrumentasi Akuisisi  
Perekaman Suara Paru – paru Pada Anak – anak Menggunakan Butterworth Band Pass Filter ,Pascasarjana  
Jurusan Teknik dan Teknik Informasi UGM.  
Endah Budiasih , Achmad Rizal , ( 2011 ) , Pengembangan Stetoskop Elektronik dan Software Analisis Auskultasi  
Fakultas Sain , Institut Teknologi Telkom Bandung.  
Pramitra Joko R,Kemalasar , Andrik Wijayanto. (2012). Identifikasi Sinyal Suara Paru Berdasarkan Power  
Spectra Density metode Welch Untuk Deteksi Kelainan Parenkim Paru, Teknik Elektronika Politeknik  
Elektronika Negeri Surabaya.  
Ramadhan, M,Z. (2012). Perancangan Sistem Instrumentas iuntuk Indetifikasi dan Analisis Suara Paru-Paru  
Menggunakan DSP TMS320C6416T, Universitas Sumatra Utara  
[Setiaagungw.blogspot.co.id/2014/05/pengertian-dan-aplikasi-rangkaian-high.html](http://Setiaagungw.blogspot.co.id/2014/05/pengertian-dan-aplikasi-rangkaian-high.html))  
Septi.2012, Poltekkes Kemenkes Malang Prodi D III Keperawatan Lawang Makalah Anatomi Fisiologi  
[Wirawan-lesmana.blogspot.co.id/2010/10/sejarah-dan-cara-kerja-Stetoskop.html](http://Wirawan-lesmana.blogspot.co.id/2010/10/sejarah-dan-cara-kerja-Stetoskop.html))  
W.Tukey, J. W. C. and J. (1965). An Algorithm For the machina Calculation Of Complex Fourier series. In  
*mathematics Of Computation* (pp. 297–301). the American Mathematic Society.