

# A novel PAPR reduction scheme based on selective mapping and a random-like coding with no explicit side information in OFDM

Fateme Kargozar

Department of Electrical Engineering, University of Tabriz, Tabriz  
PO box 5166-616471, Imam Khomeini Street, Tabriz, Iran  
Tel: +989113438165 E-mail: [Fateme.kargozar@gmail.com](mailto:Fateme.kargozar@gmail.com)

Mehrbakhsh Nilashi

Department of Computer Engineering, Roudsar and Amlash Branch, Islamic Azad University,  
Roudsar, Iran, PO box 1151-44815, Shohada Street, Roudsar, Iran  
Tel: +98-911-344-3135 E-mail: [Nilashidotnet@yahoo.com](mailto:Nilashidotnet@yahoo.com)

Othman Ibrahim

Faculty of Computer Science and Information Systems, University Teknologi Malaysia, Johor  
Alumni House, Universiti Teknologi Malaysia  
Tel: +60127477698 E-mail: [Othmanibrahim@utm.my](mailto:Othmanibrahim@utm.my)

Mousa Barisami

Department of Computer Engineering, Roudsar and Amlash Branch, Islamic Azad University,  
Roudsar, Iran  
Tel: +98-911-243-8732 E-mail: [barisamy.lahijan@gmail.com](mailto:barisamy.lahijan@gmail.com)

## Abstract

Orthogonal Frequency Division Multiplexing (OFDM) is a promising technique for high data rate and reliable communication over fading channels. The main implementation drawback of this system is the possibility of high Peak to Average Power Ratio (PAPR). In this paper, we develop a novel Selective Mapping (SLM) PAPR reduction technique. In the novel proposed scheme, the alternative symbol sequences are generated by module 2 additions of data with the rows of cyclic Hadamard matrix with the same size, inserting the selected row's number to avoid transmitting any side information and specially using a random-like Irregular Repeat Accumulate (IRA) encoder for both PAPR and Bit Error Rate (BER) better performance.

**Keywords:** IRA Codes, OFDM, PAPR, SLM method.

## 1. Introduction

Frequency Division Multiplexing (OFDM) has come to the forefront of technology over past decade because of its robustness against multipath fading channels. It is an effective high-speed data transmission scheme without using very expensive equalizers and for this reason, forms the basis of the physical layer of many broadband high data rate technologies including Digital Subscriber Line (XDSL), WiFi (IEEE802.11a/g), WiMAX (IEEE802.16a/e), and Digital Video Broadcasting (DVB).

One of the major drawbacks of OFDM systems is that the OFDM signal exhibits a high Peak to Average Power Ratio (PAPR). Such a high PAPR necessitates the linear amplifier to have a large dynamic range which is difficult to accommodate. On the other hand, an amplifier with nonlinear characteristics will cause undesired distortion in band and out of band of the signals.

To deal with this problem, many methods have been proposed such as clipping and filtering, Active Constellation Extension (ACE), Tone Injection (TI), Tone Reservation (TR), Partial Transmit Sequence (PTS), Selective Mapping (SLM) and so some methods based on coding of the transmitting data.

Clipping and filtering can reduce PAPR of the OFDM signal but introduce the in-band clipping noise to it.

Filtering is employed to remove the side-lobes generated by clipping, but it may also generate additional PAPR [3, 4]. Active Constellation Extension (ACE), Tone Injection (TI) and Tone Reservation (TR) methods don't have the previous problems, but lead to use more power in the transmitter. Phase rotation is another approach to reduce PAPR, including Selective Mapping (SLM) and Partial Transmit Sequence (PTS). These methods don't have the previous methods disadvantages such as BER performance degradation, because of out of band noise in clipping-based methods, and high power consuming, in constellation extension-based methods, so these days many researchers work on these methods optimization.

Our proposed scheme in this paper is based on a novel SLM method combined with a random-like coding of the transmitted data that have no need to use side information for detecting transmitted data in the receiver.

To make this possible to understand our proposed scheme, we organized the rest of the paper as follows: The problem of high PAPR of OFDM signal, structure of the conventional SLM scheme and the performance of IRA encoder, as our random-like coding scheme is briefly defined in section 2. Section 3 introduces our proposed technique and shows simulation results of it, in compare with the conventional SLM method. Finally, the conclusions are drawn in section 4.

## 2. Bases of the proposed method

The OFDM signal sequence  $\mathbf{a} = [a_0, a_1, \dots, a_{N-1}]$  using  $N = 2^n$  subcarriers can be expressed as

$$a_t = \frac{1}{\sqrt{N}} \sum_{k=0}^{N-1} A_k e^{j 2\pi \frac{k}{N} t} \quad 0 \leq t < N - 1 \quad (2.1)$$

Where  $\mathbf{A} = [A_0, A_1, \dots, A_{N-1}]$  is an input symbol sequence, usually modulated by using Phase Shift Keying (PSK) or Quadrature Amplitude Modulation (QAM) and  $t$  stands for a discrete time indexes.

The PAPR of the transmitted OFDM signal can be defined as

$$PAPR(a) = \frac{\max_{0 \leq t < N-1} |a_t|^2}{E[|a|^2]} \quad (2.2)$$

Where  $E$  denotes the expectation operator.

To generate  $U$  alternative symbol sequences, an input symbol sequences is multiplied by  $U$  different phase sequences, each of length  $N$ :

$$P_u = [P_{u,0}, P_{u,1}, \dots, P_{u,N-1}] \quad 1 \leq u < U \quad (2.3)$$

The first phase sequence  $P_1$  is usually the all-1 sequence. Then, the alternative symbol sequences  $A_u$

$$A_u = [A_{u,0}, A_{u,1}, \dots, A_{u,N-1}] \quad 1 \leq u < U \quad (2.4)$$

are generated. We use the expression  $A_u = A \otimes P_u$  to represent the component-wise multiplication in this form

$$A_{u,n} = A_n P_{u,n} \quad 0 \leq t < N - 1 \quad (2.5)$$

After  $U$  different alternative symbol sequences are transformed with IFFT, the OFDM signal sequence

$a_{\bar{u}} = \text{IFFT}(A_{\bar{u}})$  with the lowest PAPR is selected for transmission.

If we assume that alternative symbol sequences are mutually independent, the Complementary Cumulative Distribution Function (CCDF) expression for the SLM OFDM symbol can be given as

$$\Pr(\text{PAPR}(a_{\bar{u}}) > \text{PAPR}_0) = (1 - (1 - e^{-\text{PAPR}_0})^N)^U \quad (2.6)$$

As it explained before, we can use random-like codes in the special form of them to reduce the PAPR of these alternative symbol sequences.

The random-like codes offer capacity-achieving performance largely due to the random interleaver of the codes. Here we utilize the inherent random interleaver in the random-like codes as a scrambler to obtain candidates of independent data sequences. Shown in “Fig. 1”, a block of  $n - m$  information bits are first module2 adding with the rows of cyclic Hadamard matrix, then inserted with  $m$  label bits and encode by a random-like IRA code. These coded bits are modulated using 16-QAM modulation. IFFT is then applied to the modulated symbols. The PAPR of the discrete OFDM signal is measured with four times oversampling and by enumerating the possible sequences of inserted label bits before the encoding, we obtain different PAPR values. The selector selects the one corresponding to the lowest PAPR to transmit.

Because of the random structure of the dense generator matrix in IRA codes, each information bit could affect almost all the coded bits for a non-systematic code. Obviously, the non-systematic codes have better scrambling effect. The systematic codes are also offer good randomization by employing the interleaver before modulation.

In the systematic IRA encoder, a block of information bits  $\{d_i\}$  are encoded by an irregular repeat code with  $d_i$  repeated  $r_i$  times, where  $\{r_i : 2 \leq r_i < D\}$  are the repetition degrees of  $\{d_i\}$  and  $D$  is the maximum repetition degree. The repeated bits are interleaved to obtain  $\{u_j\}$ , and then encoded by an accumulator, given by

$$x_{m+1} = x_m + \sum_{i=0}^{a-1} u_{am+i} \quad m = 0, 1, \dots, M-1 \quad (2.7)$$

Where  $x_m$  represents parity nodes with initial states  $x_0 = 0$  and  $a$  is the grouping factor. The length of the

parity bit is  $M = \frac{n}{a}$ , where  $n = \sum_{i=0}^L r_i$ .

The final coded bits  $\{b_i\}_{i=0}^N$  are the collection of the information bits  $\{x_m\}_{m=0}^{N-L}$ .

Similar to LDPC codes, the IRA codes can be represented by a Tanner graph. Note that  $n$  is the total number of edges connecting the information bit nodes and the check nodes. Define  $\lambda_i$  as the proportion of the edges connected to the information bit node with degrees  $i$  and  $i = 2, \dots, D$  which satisfies

$$\sum_{i=2}^D \lambda_i = 1 \quad (2.8)$$

And the rate of the codes is then given by

$$\begin{aligned}
 R &= \frac{L}{L+M} = \frac{n \sum_i \lambda_i / i}{n \sum_i \lambda_i / i + \sum_i \lambda_i n / a} \\
 &= \frac{a \sum_{i=0}^D \lambda_i / i}{1 + a \sum_{i=0}^D \lambda_i / i}
 \end{aligned} \tag{2.9}$$

### 3. Simulation Results of Our Proposed Scheme

Our proposed scheme contains cyclic Hadamard matrix to modify the transmitted data in  $U$  independent form. Then, as it is shown in “Fig. 1”, we inserted these modified data with some lables that show which row of this matrix adds with the original data so these lables have the ability to eliminate transmitting side information. Then a random-like IRA encoder with a special generator matrix employed for both PAPR and BER better performance in this novel scheme. 16QAM modulating and IFFT transformation are applied and the selection part, selects the data with the lowest PAPR amount to transmit through the channel. Before transmitting, the guard interval inserter applied on data to maintain the orthogonality of the transmitted data in the fading channels in a cyclic extension method.

The structure of the receiver is shown in “Fig. 2”, while the PAPR and BER performance are demonstrated in the latter figures in compare with the conventional SLM method. “Fig. 3”, “Fig. 4”, “Fig. 5” and “Fig. 6” shows compares and results of Our Proposed Scheme.

### 4. Conclusion

This paper has introduced a novel PAPR reduction technique, in which, a random-like linear coding has been used to reduce PAPR of OFDM system in a modified SLM method. The analytical derivation of the technique has been given which describes the theoretical functionality of the technique. Simulation results show that using a random-like coding such as IRA, because of getting the ability to select a special coding structure between many random forms that gives lower PAPR has lead to better performance than the conventional SLM scheme. In addition, the presented scheme has not only shown a significant reduction in PAPR, but also, implicitly an improvement in BER without increasing the computational complexity and using any side information.

We use a polynomial to represent the repetition profile of an IRA code ensemble, i.e.

$$\lambda(x) = \sum_{i=2}^D \lambda_i x^{i-1} \tag{4.1}$$

Denote  $\bar{r}$  as the average repeat times of the bits, i.e.  $\bar{r} = \frac{n}{L}$ .

Thus, the encoder of a systematic RA codes contains  $\bar{r}L$  or  $aM$  additions. Normally  $\bar{r}$  and  $a$  are much less than the length of information bits but in general LDPC coding system we don't have these conditions. Therefore, the encoder of the systematic IRA code is much simpler than that of an LDPC code.

### Acknowledgment

This work was supported by the Iranian Telecommunication Research Center (ITRC), Iran.

### References

- Saltzberg B.R., “Comparison of single-carrier and multitone digital modulation for ADSL applications,”. IEEE Communications magazine, pp. 114-121, 1998.
- REIMERS U., “Digital video broadcasting,” IEEE Communication magazine, pp. 104-110, 1998.

Ajit Jha Md. Sohel Mahmud an Sher, S. M. Shamsul Alam, Md. Tariq Hasan and Md. Mizanur Rahman, "Reduction of Peak to Average Power Ratio (PAPR) in Orthogonal Frequency Division Multiplexing (OFDM): a novel approach based on clipping and amplification,". IEEE international Conference on Computer Sciences and Convergence Information Technology, 2009

Tomohiro Noguchi, Khoirul Anwar a, Masato Saito and Minoru Okada, "Efficient PAPR for OFDM and CI/OFDM system with iterative clipping,". IEEE, 2008.

Byoung Moo Kang, Heung-Gyoon Ryu and Sang Burm Ryu, "A PAPR reduction method using new ACE (Active Constellation Extension) with higher level constellation," IEEE international conference on signal processing and communication. 2007.

Tao Jiang and Yiyang Wu, "An overview: peak to average power ratio reduction techniques for OFDM Signals," IEEE transaction on broadcasting. 2008

Dae-Woon Lim, Hyung-suk Noh, Hyun-Bae Jeon, Jong-Seon No, and Dong-Joon Shin, "Multi-stage TR scheme for PAPR reduction in OFDM signals. IEEE transactions on broadcasting. 2009

Kyn-Hong Kim, Hyun-Bae Jeon, Jong-Seon No and Dong-Joon Shin, "New SLM scheme for PAPR reduction in OFDM Signals,". International Symposium on Information Theory and its Applications (ISITA). 2008

Athinarayanan Vallavaraj, Brian G Stewart, David K Harrison and Francis G McIntosh. "Reducing the PAPR of OFDM using a simplified scrambling SLM technique with no explicit side information," IEEE international conference on parallel and distributed systems. 2008.

Houshou Chen, Jyun-Jie Wang, Cheng-En Tu Hsing-Wang Chang, "PAPR reduction in OFDM systems based on modified PTS algorithm with non-disjoint partition," IEEE. 2009.

Guosen Yue and Xiaodong Wang, "A hybrid PAPR reduction scheme for coded OFDM," IEEE transaction on wireless communications, 2006.

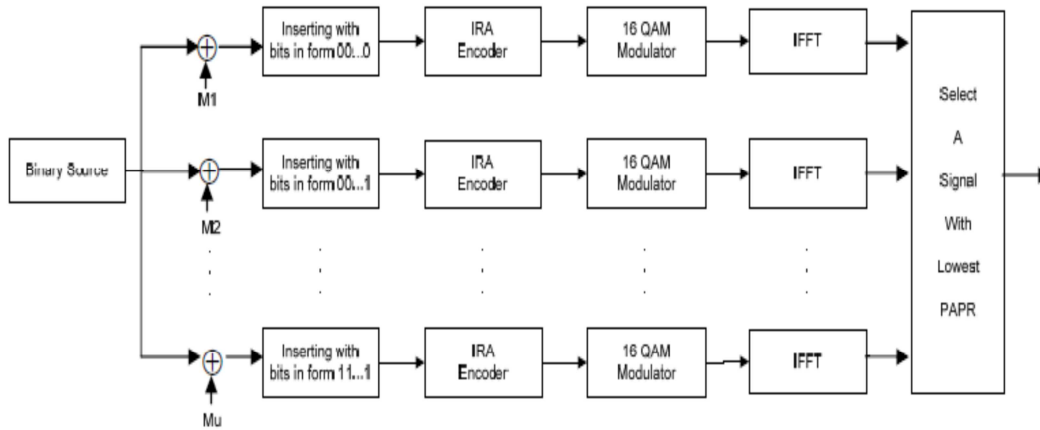

Figure 1. Transmitter of the proposed scheme

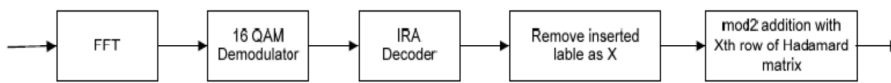

Figure 2. Receiver of the proposed scheme

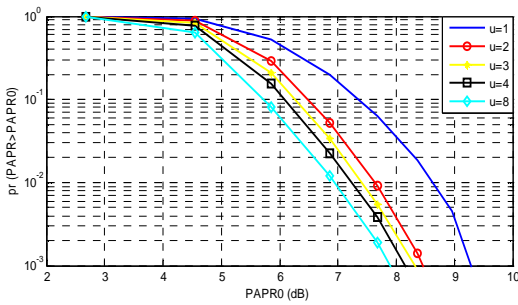

Figure 3. PAPR performance of the conventional scheme

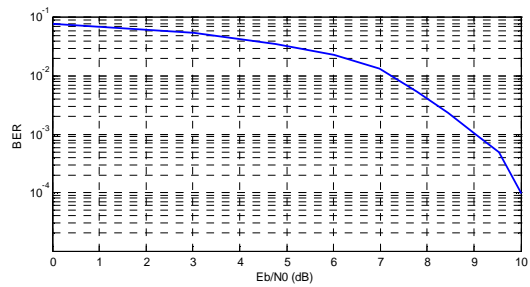

Figure 5. BER performance of the conventional scheme

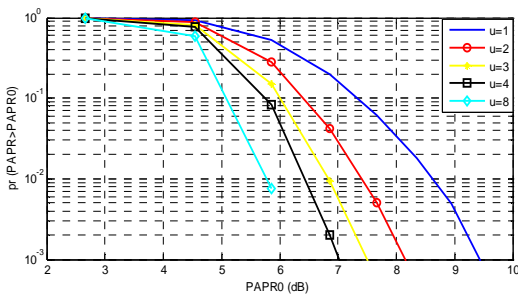

Figure 4. PAPR performance of the proposed scheme

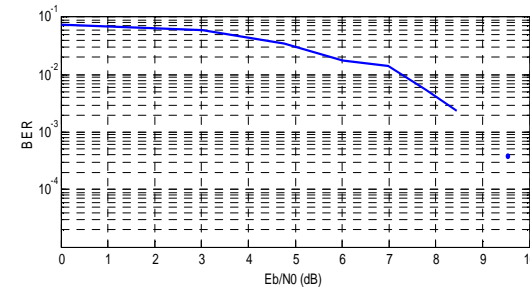

Figure 6. BER performance of the proposed scheme

This academic article was published by The International Institute for Science, Technology and Education (IISTE). The IISTE is a pioneer in the Open Access Publishing service based in the U.S. and Europe. The aim of the institute is Accelerating Global Knowledge Sharing.

More information about the publisher can be found in the IISTE's homepage:

<http://www.iiste.org>

The IISTE is currently hosting more than 30 peer-reviewed academic journals and collaborating with academic institutions around the world. **Prospective authors of IISTE journals can find the submission instruction on the following page:**

<http://www.iiste.org/Journals/>

The IISTE editorial team promises to review and publish all the qualified submissions in a fast manner. All the journals articles are available online to the readers all over the world without financial, legal, or technical barriers other than those inseparable from gaining access to the internet itself. Printed version of the journals is also available upon request of readers and authors.

### **IISTE Knowledge Sharing Partners**

EBSCO, Index Copernicus, Ulrich's Periodicals Directory, JournalTOCS, PKP Open Archives Harvester, Bielefeld Academic Search Engine, Elektronische Zeitschriftenbibliothek EZB, Open J-Gate, OCLC WorldCat, Universe Digital Library, NewJour, Google Scholar

