

Ditransitivity in Ga: A Lexical Functional Approach

Yvonne Akwele Amankwaa Ollennu

Faculty of Ghanaian Languages Education, University of Education, Winneba. Ajumako Campus

Abstract

The paper examines diathesis alternation of Ga and English ditransitive verbs. It discusses simple ditransitive verbs found in English and compares them with Ga verbs that can be used in ditransitive constructions. Ditransitive verbs are known to subcategorise for two noun phrases as objects. The semantic arguments found in ditransitive constructions are most often the beneficiary followed by the theme. In English, ditransitivity is linked to dative shift. The NP that bears the semantic role of beneficiary /goal in a ditransitive construction is preceded by the theme. The verb, in this instance, then subcategorises for NP followed by PP syntactically. The PP bears the semantic role of the beneficiary and the NP bears the role of the theme. In ditransitive alternation, the semantic roles of the NP objects do not change. What differs in the construction is the syntactic form. Part of the paper will show some analysis using Lexical Functional Grammar (LFG). Data was gathered in consultation with native speakers for the analysis. It was evident that in Ga the constructions used to express dative shift of ditransitive were multiverb constructions and some of the verbs that were used to express ditransitivity were inherent complement verbs with subordinate clauses as their complements.

Keywords: ditransitive, diathesis alternation, semantic role, multiverb, ditransitivity

1. Introduction

Verbs as main predicates in languages may be transitive, intransitive or ditransitive. The paper focuses on ditransitive verbs in Ga, a Kwa language of the Niger Congo Branch. Ga is mainly spoken along the coastal areas in the Greater Accra region in Ghana in areas such as Ga Mashi, Osu, La, Teshie, Nungua and Tema. Ga, a two tone language (high and low), is mainly an SVO language. Haspelmath (2015) postulated that ditransitive constructions are syntactic constructions that consist of three arguments with the semantic role of agent, theme and recipient and these denote event of possessive transfer or cognitive transfer events. The semantic arguments found in ditransitive constructions are most often the beneficiary followed by the theme. (Yule 1996, Levin 1993, Palmer 1981). Ditransitive verbs normally take three arguments namely the subject, the indirect object and direct object. This means that in addition to the subject, they subcategorise for two complements. The semantic role for the subject is most often agent and patient/theme and beneficiary are the roles for the objects (direct and indirect) Kotey (2014:42). A ditransitive construction was also defined by Malchukov et al (2007:2) as a construction that has a (ditransitive) verb, an agent argument (A), a recipient-like argument (R), and a theme like argument (T). From the definitions mentioned it is simply a verb that has three arguments namely subject, indirect and direct object with the semantic roles of agent, recipient/beneficiary and theme respectively. The paper aims to examine verbs in Ga that occur in ditransitive constructions and investigates their thematic roles as well as examine whether they can undergo diathesis alternation. This analysis was done in comparison with English and the differences outlined from the findings at the end of the paper.

1.1 Methodology

This paper examines verbs that can be used in ditransitive constructions. These verbs will be grouped based on Levin (1993). Levin (1993) discussed five groups of verbs and how they are used in ditransitive constructions. She looked at the semantic roles of the noun phrases in the object positions. Her discussion indicated that the semantic roles remain the same. The data examined for the paper were arrived at in consultation with native speakers to confirm their grammatical forms. These consultants were six teachers of Ga made up of two males and four female teachers with average age of thirty. These were teachers who had taught between five to twenty years of Ga. The verbs were examined based on Levin (1993) verb classes. The sentences were examined and the semantic roles assigned to them and their syntactic structure were analysed and compared to the English. The Lexical Functional Grammar was used to draw some tree diagrams in the analysis.

2. Related Works

Ditransitive constructions have been examined in the literature among scholars such as Miyagawa and Tsujioka (2004), Gerd (2005), Dyakonova (2007), Kibort (2008), Haspelmath (2015) among others from different perspectives. In Japanese, Matsuoka (2003) opined that two types of ditransitive verbs that the dative argument associate with different structural positions. This was seen clearly in the Japanese causative inchoative alternations of the verbs that are ditransitive. He further noted that the semantic roles of the dative argument change as in one construction it is a goal and in another it is experiencer. Dyakonova (2007) did a syntactic analysis in Russian and claimed that the goal is outside the verb phrase that denotes the event and the functional

applicative head introduces this argument as she refuted earlier proposal that the direct object which is the accusative theme c-commands the indirect object which is a dative goal. Miyagawa and Jung (2004) did a sort of semantic analysis by looking at the decomposition of ditransitive verb ‘give’ and postulated that in double object verb like ‘give’ CAUSE is evident which is seen in its case marking as was clear in the Korean data examined. Synder (2003) examined the relationship between the syntax, semantics and pragmatics of ditransitive constructions. The focus of the paper is to examine ditransitivity in Ga to find out how they are expressed syntactically and also to find the verbs that can occur in this construction and in addition to contribute to the typology of ditransitivity constructions.

3. Theoretical Framework

The paper groups the verbs into the Levin (1993) verb classes and also makes use of Lexical Functional Grammar (LFG) to analyse some sentences. Lexical Functional Grammar is ‘a nontransformational theory of Linguistic structure which assumes that language is best described and modeled by parallel structures representing different facets of linguistic organization and information, related to one another by means of functional constraints’ Darymple (2001:1). LFG assumes two syntactic levels of representation: c(onstituent)-structure which encodes phrasal dominance and precedence relations represented as a phrase structure tree; f(unctional) –structure encodes syntactic predicate argument structure and is represented as an attribute-value matrix. The f-structure contains attributes like PRED, SUBJ, and OBJ. the PRED value is considered to be semantic value. The relationship between c-structure trees and the corresponding f-structure is by a functional projection function θ from the c-structure nodes to f-structure attribute-value matrices. A simple tree diagram and f-structure for an illustration is in (1) below.

1). Janet eats mangoes.

c- structure

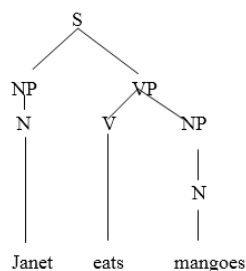

f-structure

| | |
|------|-------------------|
| PRED | 'EAT< SUBJ, OBJ>' |
| SUBJ | PRED 'JANE' |
| OBJ | PRED 'MANGOES' |

S → NP VP
 (↑SUBJ) = ↓ ↑ = ↓

VP → V NP
 ↑ = ↓ (↑ OBJ = ↓)

In the lexical entry constraint, the \uparrow metavariable refers to the 0-image of the mother c-structure node and the metavariable refers to the 0-image of the nonterminal labeled by the constraint. Lexical entries also use the metavariable \downarrow to encode information about f-structures of the preterminal nodes. A simple analysis for Janet is

Janet: N (\uparrow PRED) = JANET
 (\uparrow NUM) = SG
 (\uparrow GEND) = FEM
 (\uparrow PERS) = 3

Two important features are peculiar to LFG. First it is lexical and not transformational; secondly, it is functional and not configurational. It is said to be lexical as it states relations among different verbal diatheses in the lexicon rather than by means of syntactic transformations and configurational in the sense that abstract grammatical functions are primitives of the theory and are not defined in terms of phrase structure configurations or of semantic argument relations. Darymple (2001:3-4).

4. Analysis and Discussion

The paper now discusses briefly the five types of verbs discussed by Levin (1993) that can be found in English ditransitive constructions. The term ‘ditransitivity’ here is used to mean using a verb to subcategorise for noun phrase (NP) and prepositional phrase (PP). The NP plays the semantic role of theme and the PP plays the role of beneficiary/goal. That is, when, the construction has undergone dative shift or diathesis alternation. Diathesis alternation is used interchangeably with dative shift in this paper. Semantic roles of phrases do not change when they undergo dative shift Kroeger (2002:68-71) but this was not so in Japanese as noted by Matsuoka (2003)

where the thematic roles of dative arguments of two types of verbs found in ditransitive constructions differ as in one it is a goal and in one it is experiencer.

4.1 Verbs of Change and Possession

The prototypical ditransitive verb is ‘give’. Its semantic participants are theme and goal/beneficiary. The theme is preceded by the goal/beneficiary in the construction. In diathesis alternation, the theme precedes the goal/beneficiary. What is different here is the syntactic structure; the verb is followed by the object (NP) which is then followed by the oblique theta (PP). The verb in a dative construction then subcategorises for an NP followed by a PP. the subcategorisation frame for the verb will be: V[____ NP PP]. An example in English is

2) Ama gave Kofi the book.
 Agent Beneficiary Theme

When the sentence in (2) undergoes diathesis alternation it becomes

3a) Ama gave the book to Kofi.
 Agent theme beneficiary

The Ga example in (3b) is from the verb of change and possession

3b) Amá há yòò lè wòò
 Ama give.PST woman DEF book

“Ama gave the woman a book”.

The verb *ha* ‘give’ also behaves the same way as the English verb give which subcategorises for two noun phrases as objects. The theme *wolo* ‘book’ is preceded by the beneficiary *yòò lè* ‘the woman’ in (3b). The verb *ha* can be used to constructionally express ‘ditransitivity’ as illustrated in example (4) below.

4) Amá ké wòò há yòò lè
 Ama move book give.PST woman DEF

“Ama gave a book to the woman”.

When the verbs in this group are used to express ‘ditransitivity’ in Ga the construction employed consists of a pre-verb/ bleached verb/verbid and the main verb *ha* ‘give’. This could be referred to as a verbid clause or multiverbal construction. The bleached verbs are verbs that seems to have lost some of its properties as time goes on as claimed by Kotey (2014:54). Kotey (2014) cited that Dakubu (1970) calls such verbs pre-verbs and noted that some play the prepositional role in Ga especially *ké*. Furthermore, such verbs were referred to as verbid (Ansre 1966) to indicate that they are from verbs as cited in Kotey (2014:54). The verbid *ké* is what has occurred in example 4. Kotey (2014:55) said *ké* can be given the English translation ‘move with, act with, act by means of’ as it denotes some kind of movement and can simply be glossed ‘move’. She further opined that bleached verbs cannot occur alone and be meaningful as they lack descriptive content but must adjoined to a main verb and other bleached verbs she noted were in Ga are *ba* and *ya..* However, she stated that the bleached verb or verbid stands alone when the NP follows immediately after it. This is what is seen in example (4) where the NP *wolo* ‘book’ occurs after it and therefore preceded the main verb. It must be noted that the semantic roles of the NP remain the same.

Below is a tree diagram from LFG analysis to examine the example in (3b) which has the verb *ha* (give).

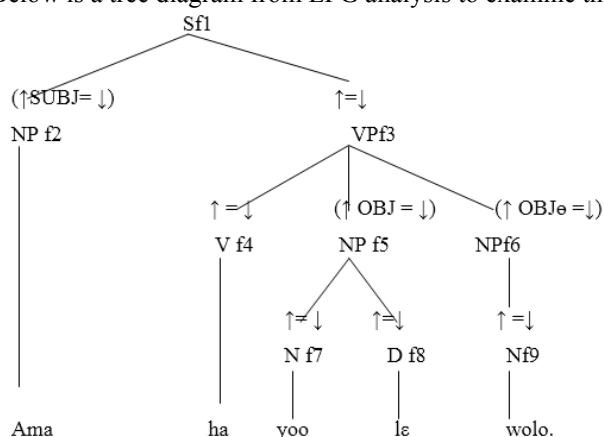

Morpholexical Specifications:

Ama : N (↑ PRED) = Ama
wolo : N (↑ PRED) = book.
yoo :N (↑ PRED) = woman.
Ha: V (↑PRED) ‘give’ < SUBJ, OBJ, OBJe>
 TENSE: PAST
Ke: V ‘move’ < SUBJ, OBJ, XCOMP>

le :D (↑PRED) = the
 DEF = +

The f-structure is below

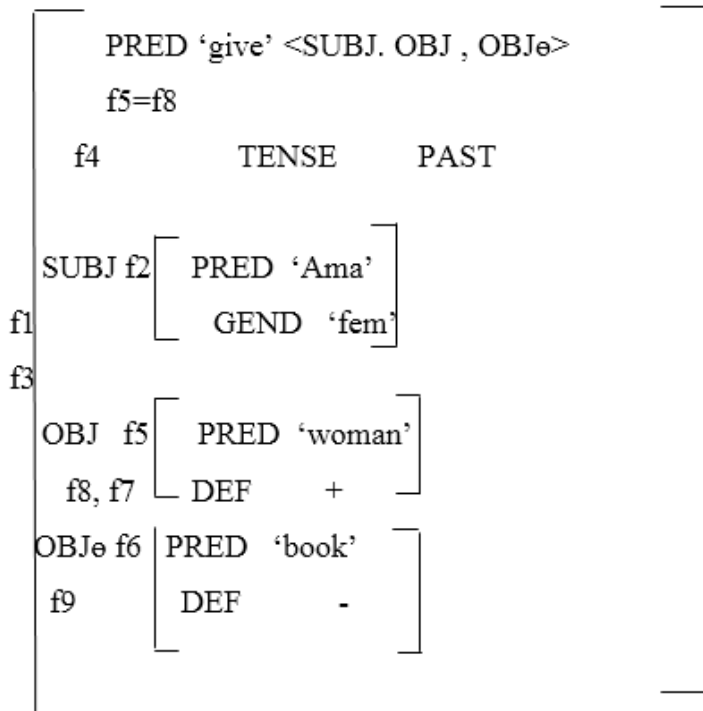

Functional Equations:

$$f1SUBJ = f2 \quad f1 = f3 \quad f3 = f4$$

$$f3OBJ = f5 \quad f5 = f7$$

$$f6 = f9$$

Below is a c-structure for a verbid construction having the verbs *kε* and *ha* in the construction.

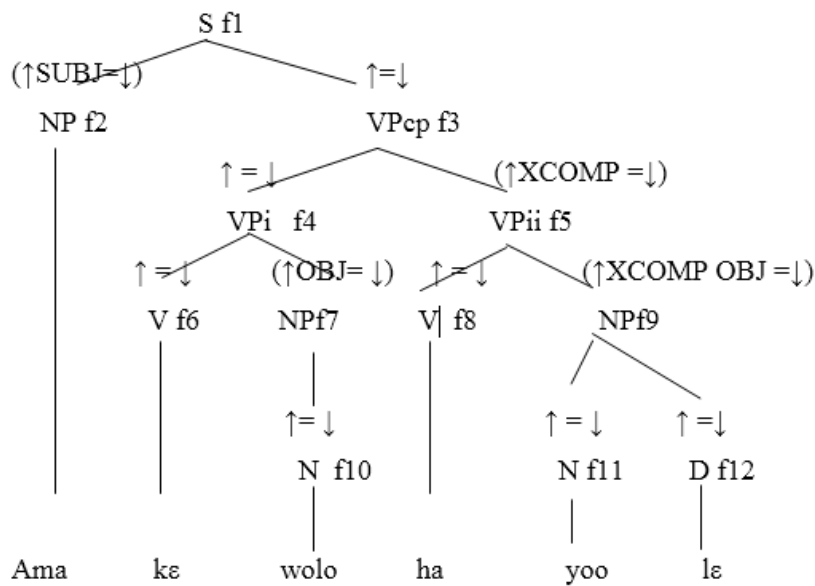

The f-structure is below for the example 4.

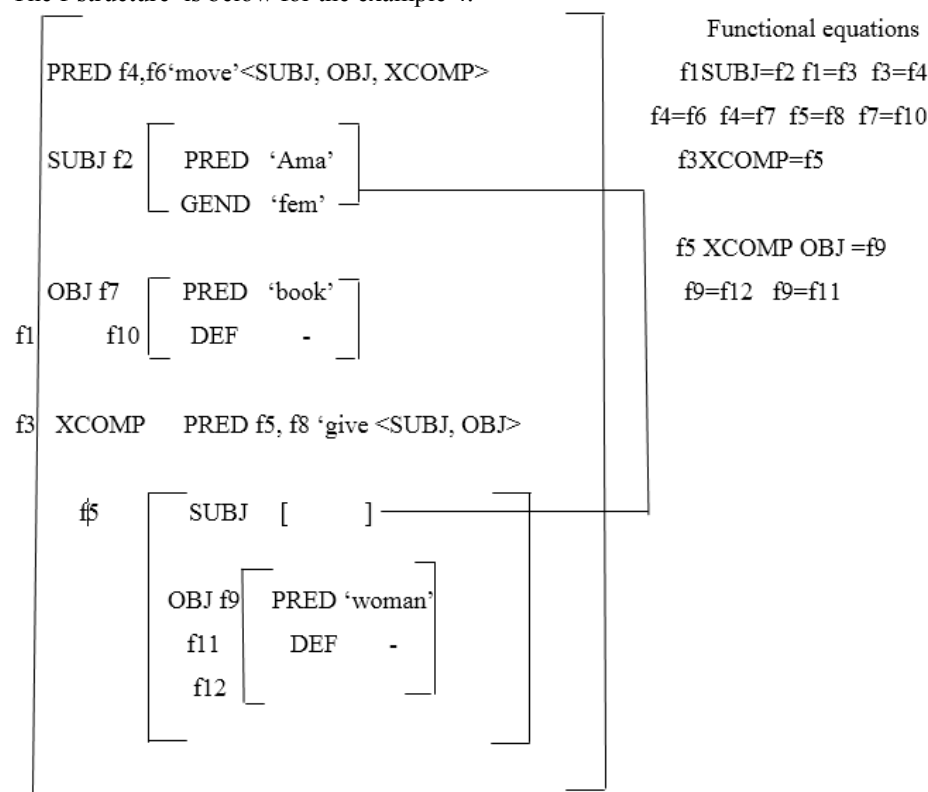

(adopted from Bresnan (2001) and Darymple (2002)).

From the Ga example (4) when the sentence undergo dative shift the construction changes entirely unlike the English. It can be said that this group is expressed differently in Ga.

4.2 Verbs of Sending and Carrying

A verb like 'send' is one of the verbs found under this type. This verb also behaves like the verb 'give' and can also undergo diathesis alternation in the same way as the verb of change and possession. Example is seen in (5a).

5a) James sent the woman a parcel.

The beneficiary is 'the woman' and the theme is 'a parcel' when dative shift is applied it will be

5b) James sent a parcel to the woman.

where the theme 'a parcel' now preceded the beneficiary 'the woman in (5b).

An example in Ga is illustrated in (6a) from the group verbs of send and carry

6a) Amá màjé yòò lè wòlò.

Ama send.PST woman DEF. book

"Ama sent the woman a book".

6b) Amá màjé yòò wòlò.

Ama send.PST woman book

Ama sent a woman a book.

In (6a) the verb *maje* 'send' behaves the same way as with the English verb 'send'. In (6b) the NP are both indefinite which is possible in Ga. In examples (4), (6a) and (6b) each NP bearing the semantic role 'theme can be definite unlike Akan, another Kwa language Osam (2003). This is illustrated below in (7).

7) Amá há yòò lè wòlò lè.

Ama give.PST woman DEF book DEF

"Ama gave the woman the book"

When the construction with the verb *maje* 'send' also undergoes dative shift, the construction will be as shown in (8).

Alternation :

8) Amá ké wòlò màjé yòò lè.

Ama move book send.PST woman DEF

"Ama sent a book to the woman".

The construction in the example (8) consist of two verbs 'ké' 'to move' and the verb *maje* 'send'. The first verb

ké ‘to move’ is never inflected in Ga verbid construction. The second verb, in this instance is, what takes the inflection in Ga.

This group when compared with the English behaves differently in the dative shift where the construction becomes multiverb construction in which the first verb is a verbid and a main verb occurs instead of the NP followed by PP in the English dative shift.

4.3. Verbs of Communication

This type of verbs is for communication. This group includes verbs like ‘tell, teach, and show’. Just like the verbs of change and possession, the communication verbs have the NPs which bear the semantic role of theme preceded by the NPs which play the semantic role of goal /beneficiary. This group can also undergo dative shift/diathesis alternation. In an example like (9a).

9a) Mary taught Janet History.

The beneficiary is Janet and the theme is History in (9a), when dative shift is applied the semantic roles remain the same but the noun phrases change their position and verb now subcategorises for NP and PP becomes

9b) Mary taught History to Janet.

Below are examples in Ga from the verb of communication.

10a) Adote tá/ gbà /kèé Adole àdèsá.

Adote tell /narrate/ say Adole story

“Adote told Adole a story”.

10b) Ayi tsòò Adole akontaa.

Ayi teach.PST Adole maths

“Ayi taught Adole maths”

10c) Adote ké fòtó tsóó Ayi.

Adote move picture show.PST Ayi.

“Adote showed a picture to Mary”.

In (10a) the three verbs have the same meaning in the sentence ‘Adote told Adole a story’. The verb *tá* is exclusively used to mean ‘tell a story’. The verb *gbà* ‘to narrate’ can also be used to mean ‘tell/narrate’ a story or an event. The verb *kèé* ‘to say’ is not often used to mean ‘tell a story’ though it can be used to mean ‘tell’ or ‘inform’. The theme in (10a) *ades* ‘story’ cannot be interchanged with Adole ‘name of a person’ the beneficiary unlike English where the dative shift will cause this change.

The verb in (10b) *tsòò* ‘teach’ is the same verb in (10c), that is the second verb also has the meaning ‘show’. When the verb means ‘show’ the construction used most often is strictly a multiverb construction with the first verb being a bleached verb as in (10c). It is the only single way to express it. The noun phrase in the construction having the verb *tsòò* gives the meaning of the verb either to be ‘teach or show’. The verb *tá* ‘to tell a story’ cannot be used in multiverb verb construction where *ké* occurs as a verbid to express ditransitivity’ or undergo the diathesis alternation. When the verb *tsòò* means teach as in (10b) it cannot undergo diathesis alternation.

I may say that this group of verbs in Ga behaves differently as the construction before and after dative shift is different from the English as illustrated from the examples.

4.4 Image Creation Verbs

This group has verbs like ‘carve, paint, and draw’. The group behaves in a similar manner as the three types of verbs discussed above. The only difference is when creative verbs undergo dative shift, the PP is headed by ‘for’ and not ‘to’. This is illustrated in (11a) below.

11a). Dennis carved a doll for Sally.

11b). * Dennis painted a picture to Sally.

The (11b) above is ungrammatical, because the PP is headed by ‘to’ and the verb though subcategorising for two objects must have the PP headed by ‘for’.

The Ga examples (12-13) below consist of image creation verbs.

12) Kofi gbò tsòòbí há Adole.

Kofi carve.PST doll give Adole

“Kofi carved a doll for Adole”.

13) Kofi téj sèi há Amá.

Kofi draw.PST chair give Ama

“Kofi drew chair for Ama”

In examples (12) and (13), the constructions are the Serial Verb Construction (SVC). SVC “.....these are constructions in which verbs sharing a common actor or objects are merely juxtaposed, with no intervening conjunctions” Folsen & Olsen (1988:18). A sentence that contains a serial verb consists on the surface at least, of a subject noun phrase, followed by a series of two or more verb phrases, each containing a finite verb plus, possibly the complements of that verb (Schachter 1974a: 254). Aikhenvald (2005:1) defines SVC as “a

sequence of verbs which acts together as a single predicate without any overt marker of coordination, subordination or syntactic dependency of any sort”. Put simply, it is a construction which contains two or more verbs which code one single event and have the same subject referent. The NP bearing the semantic role, theme, appears after the first verb but after the second verb comes the NP playing the semantic role of beneficiary. The verbs in (12) and (13) can also take only an object in a construction but our focus here is using it to subcategorise for two objects.

From the examples in (12) and (13), I may conclude that Serial Verb Constructions are what is employed to express ditransitivity for this group of verbs in Ga unlike English. The SVC cannot undergo dative shift in this circumstance.

4.5 Verbs of Future Having

In this group the verbs found mainly are ‘promise and offer’. They behave just like the image creation verbs discussed in 4.4. A simple example will be

14) The gentleman offered the lady a job.
 Agent beneficiary theme.

When the sentence in (14) undergoes diathesis alternation it becomes as shown in (15).

15) The gentleman offered a job to the lady.
 Agent theme beneficiary.

(16) and (17) below are Ga constructions containing the verbs of promise and offer

16) Nùù lè wò shi áké é-bàa -há lè blòdò.
 man DEF add down COMPL 3sg -FUT -give DEF bread

“The man promised to give him bread”.

17) Yòò lè há gbèkenuu lè nitsúmò.
 Woman DEF give.PST child DEF job

“The woman gave/offered the young boy a job”.

In (16), the inherent complement verb *wo shi* (promise) takes a complementizer clause which begins with ‘...*áké* (that)’. In (17), the verb used to mean offer is *ha* ‘give’. This is because the same verb can be used to have both meanings depending on the construction. Example (16), construction has a different syntactic structure from the diathesis alternation construction and (17) had to make use of the verb *ha* which has two meanings give/offer. It can be said therefore that even though these English verbs promise and offer can be found in Ga, *wo shi* ‘promise’ cannot be used in dative shift constructions *wo shi* (to promise) and the other verb *ha* is already found under the verb of change and possession can occur in dative shift. This verb group promise and offer can be said to behave syntactically different in Ga unlike English where it exists and can be used in the dative shift construction.

5. Findings

In summary, the paper discussed ditransitive in Ga. The underlying form for diathesis alternation is

Verb Phrase = Verb Noun Phrase Prep. Phrase it then becomes

Verb Phrase = Verb Noun Phrase Noun Phrase

It came to light that this underlying form for diathesis alternation to express ditransitivity does not work for all the Ga verbs. Some of the verbs in Ga when they are used to express ditransitivity come in an SVC construction and the Phrase Structure Rule for the VP in the SVC will be as below.

VP → V NP V NP.

The VP in the SVC then becomes recursive and can therefore be said to be a complex VP. In the SVC, the theme occurs after the first verb and the semantic argument beneficiary/goal appears after the second verb. It came to light also that some of the Ga verbs like *ha* ‘give’ can have the subcategory frame VP = [_ NP NP]. The paper also revealed that in some instances of dative shift the construction in Ga has a bleached verb and a main verb unlike English.

The verbs can also be used to show ‘ditransitivity’ in an SVC. Verbs like ‘*tsòò* to show’ never have this subcategory frame VP = [_ NP NP], but only express ‘ditransitivity’ in SVC. The meaning of this verb ‘*tsòò*’ depends on the noun phrases that occur with it. It may mean ‘teach or show’ depending on the selected NPs.

It was revealed also that unlike Akan, another Kwa language the semantic argument ‘theme’ in Ga can be definite in the construction. Both NPs in the construction can therefore be definite.

Finally, I may say that the verb types discussed by Levin (1993) may not all be found in Ga, in terms of English grammar. The only type found is the VERBS CHANGE OF POSSESSION. The other four types VERBS OF SEND AND CARRY, IMAGE CREATION VERBS and VERBS OF FUTURE HAVING are not expressed the same as in English ditransitives when dative shift is applied. Strictly, the last type VERB OF

FUTURE HAVING is not found but is expressed syntactically different as compare to English. The construction of verbs found in verbs of future having had a different syntactic structure unlike English with which it is being compared with. However, on the whole a multiverb construction with the bleached verb k or SVC can be used to show that ditransitivity can be expressed in Ga.

6. Conclusion

The paper has attempted to bring to light that the verb types postulated by Levin (1993) exist in Ga but syntactically they are expressed different from English. The semantic roles for these verbs are the same for both Ga and English even if dative shift is applied to the construction where possible. Few of the constructions were analysed using simple LFG. This is a stepping stone to further carry more investigation into other verb types and their transitivity to find out their similarities or peculiarities in languages.

References

- Ansre, G. (1966). The Verbid: A caveat to serial verb. *Journal of West African Languages*. 3(1) 29-32.
- Aikhenvald, A. Y. (2005). Serial Verb Constructions in Typological Perspective. In Aikhenvald and Dixon (Eds) *Serial Verb Constructions*. 1-68
- Bresnan, J. (2001). *Lexical- Functional Syntax*. Oxford. Blackwell Publishers:
- Dakubu, M.E.K. (1970). The categories of the Ga verbal group. *Journal of African Languages*. 9(2) 70-76.
- Darymple, Mary (2001). *SYNTAX and SEMANTICS. VOLUME 34. Lexical Functional Grammar* : Academic Press.
- Dyakonova, M. (2007). Russian Double Object Constructions. ACLC Working papers 2(1). 3-30.
- Gerd, C. (2005). The coding of ditransitivity in Tocharian. Working Papers 51 Lund University Publications.
- Haspelmath, M. (2015). Ditransitive Constructions. *Annual Review of Linguistics*1:9-41
<http://doi.org/10.1146/annurev-linguist-030514-125204>.
- Foley, W.A. & Olsen, M. (1988). Clausehood and Verb Serialisation. In *Johanna Nichols & Anthony C Woodbury ed Grammar Inside and Outside the clause – some approaches to theory from the field*. Cambridge. Cambridge University Press, 17-66.
- Jung, Y. and Miyagawa, S. (2004). Decomposing Ditransitives Verbs In *Proceedings of SICGG*, Summer 2004. 101- 120.
- Kibort, A. (2008). On the Syntax of Ditransitive Constructions. In Miriam Butt and Tracy Holloway King (eds) *Proceedings of the LFG08 Conference*. CA. CSLI Publications. <http://csli-publication-standford.edu>
- Kordoni, V. (2004). Between Shifts and Alternations: Ditransitive Constructions. In *Stefan Muller (ed) Proceedings of the 11th International Conference on Head-Driven Phrase Structure Grammar*. Stanford. CA CSLI Publications. Pp. 151-167. <http://csli-publications.stanford.edu/HPSG/2004>
- Kotey, C. (2014). The Inflectional Morphology of Ga Verbs: The Case Infl-To Verb Movement. Doctoral Thesis, Department of Linguistics and Nigerian Languages. University of Ilorin
- Kroeger, Paul (2002). *Analyzing Syntax: A Lexical Functional Approach*. Pre- Publication Draft Spring 2002 GIAL DALLAS
- Levin, Beth, (1993). English Verb Classes and Alternations. A Preliminary Investigation. University of Chicago Press.
- Malchukov, A, Haspelmath, M & Comrie, B. (2007). Ditransitive Constructions. A typological Overview. First Draft
- Matsuoka, M. (2003). Two types of Ditransitive Constructions in Japanese. *Journal of East Asian Linguistics* Vol 12 pp 171-203. <http://doi.org/10.22472/109327>
- Miyagawa, S. & Tsujioka, T. (2004). Argument Structure and Ditransitive Verb in Japanese. *Journal of East Asian Linguistics* 13(1), 1-38. <http://doi.org/10.1023/B:JEAL.0000007345.64336.84>
- Osam, E. K. (2003). *Introduction To The Structure of Akan, its verbal multi-verbal System*. Trondheim Summer School NTNU. June 23-27, 2003.
- Palmer, F.R. (1981). *Semantics*. Second Edition. Cambridge. Cambridge University Press.
- Schachter, P. (1974a). *A non-transformation account of serial verbs*. *Studies in African Linguistics*, Suppl. 5, 253-270.
- Snyder, K.M. (2003). The relationship between *form and *function in Ditransitive Constructions <http://repository.upenn.edu/dissertation/AA13095944>.
- Yule, G. (1996). *The Study of Language*, Second Edition. Cambridge: Cambridge University Press

List of Abbreviations

DEF : definite article
COMPL: complementizer
N : noun
Neg : negative particle
OBJ : object
OBJ θ : object theta
PRED : predicate
Prep : preposition
PST : past tense
3sg : third singular pronoun
SUBJ : subject
V : verb
VP : verb phrase
VP cp : complex verb phrase
VPi : first complex verb phrase
VP ii : second complex verb phrase