

## Construction of Magnetohydrodynamic Cell for Magnetic Treatment of Water

Oleg Mosin<sup>1</sup>     Ignat Ignatov<sup>2\*</sup>

1. PhD (Chemistry), Moscow State University of Applied Biotechnology,

Talalikhina St., 33, Moscow 109316, Russia

2. DSc, Professor, Scientific Research Center of Medical Biophysics (SRCMB),

Nik. Kopernik St., 32, Sofia, 1111 Bulgaria

\* E-mail of the corresponding author: mbioph@dir.bg

### Abstract

This review article outlines an overview of new trends and modern approaches for practical implementation of magnetic water treatment to eliminate scaling salts (carbonate, chloride and sulfate salts of  $\text{Ca}^{2+}$ ,  $\text{Mg}^{2+}$ ,  $\text{Fe}^{2+}$  and  $\text{Fe}^{3+}$  cations) in power heat-exchanger devices and pipe lines. The principles of physical effects of the magnetic field on  $\text{H}_2\text{O}$  molecules as well as the parameters of physico-chemical processes occurring in water and the behavior of the dissolved in water scaling salts subjected to the magnetic treatment are discussed. It is demonstrated that the effect of the magnetic field on water is a complex multifactorial phenomenon resulted in changes of the structure of hydrated ions as well as the physico-chemical properties and behavior of dissolved inorganic salts, changes in the rate of electrochemical coagulation and aggregate stability (clumping and consolidation), formation of multiple nucleation sites on the particles of fine dispersed precipitate consisting of crystals of substantially uniform size. There are also submitted data on constructive features of magnetohydrodynamic cell based on the permanent magnets and electromagnets (solenoids) as hydro magnetic systems (HMS), magnetic transducers (MT) and magnetic activators (MA) of water. It was estimated the efficiency of using the various magnetic water treatment devices in water treatment technologies.

**Key words:** magnetic field; magnetic water treatment; magnetohydrodynamic cell; scaling salts.

### Introduction

As is known, the effect of magnetic field on water bears a complex and multifactorial character that in the final result affects the structure of water and hydrated ions as well as the physico-chemical properties and behavior of dissolved inorganic salts (Ochkov, 2006). When being applied to water, the magnetic field therein changes the rates of chemical reactions due to the occurrence of competing reactions of dissolution and precipitation of the dissolved salts, facilitates the formation and decomposition of colloidal complexes, and improves electro-coagulation followed by sedimentation and crystallization of scaling salts of  $\text{Ca}^{2+}$ ,  $\text{Mg}^{2+}$ ,  $\text{Fe}^{2+}$  and  $\text{Fe}^{3+}$  (Klassen, 1978).

Hypotheses explaining the mechanism of action of the magnetic field on water are divided into three main

groups – colloidal, ionic and water hypotheses.

The first hypotheses assume that under the influence of the magnetic field in the treated water there occurs a spontaneous formation and decay of colloidal complexes of metal cations -  $\text{Ca}^{2+}$ ,  $\text{Mg}^{2+}$ ,  $\text{Fe}^{2+}$  and  $\text{Fe}^{3+}$ , which fragments of decay further forming the centres of nucleation of inorganic salts that accelerates their subsequent sedimentation. It is known that the presence of metal cations (particularly,  $\text{Fe}^{3+}$ ) and microinclusions of ferromagnetic iron particles of  $\text{Fe}_2\text{O}_3$  in water intensifies the formation of colloidal hydrophobic sols of  $\text{Fe}^{3+}$  cations with chlorine  $\text{Cl}^-$  anions and neutral  $\text{H}_2\text{O}$  molecules having the general formula  $[\text{xFe}_2\text{O}_3 \cdot \text{yH}_2\text{O} \cdot \text{zFe}^{3+}] \cdot 3\text{zCl}^-$ , which may cause the formation of nucleation centers which surface adsorbs calcium  $\text{Ca}^{2+}$  and magnesium  $\text{Mg}^{2+}$  cations (forming the basis of the carbonate hardness of water) that leads to the formation of fine crystalline precipitation as a sludge (Krechetov, 1984). Thus, the more stable the ion hydrate shell is, the more difficult they converge or deposit on the adsorbent complexes formed on the surfaces between the liquid and solid phases.

The hypotheses of the second group explain the action of the magnetic field on water by polarization of dissolved ions and deformation of their hydration shells by the magnetic field, accompanied by a decrease of hydration - an important factor that contributes to the solubility of the dissolved salts in water, electrolytic dissociation, distribution of various substances between solid and liquid phases, kinetic constants and equilibrium chemical reactions rates in aqueous solutions, which in its turn increases the likelihood of convergence of the hydrated ions and sedimentation processes and crystallization of inorganic salts (Martynova *et al.*, 1969). In the scientific literature there is experimental evidence that under the influence of the magnetic field there occurs a temporary distortion of hydration shells of the dissolved in water ions that alters their distribution between the solid and the liquid phase (Chesnokova, 1971). It is assumed that the influence of the magnetic field on the dissolved in water ions of  $\text{Ca}^{2+}$ ,  $\text{Mg}^{2+}$ ,  $\text{Fe}^{2+}$  and  $\text{Fe}^{3+}$  can be also associated with the generation of a weak electric current in a moving stream of water or with the pressure pulsation (Kronenberg, 1985).

The hypotheses of the third group postulate that the magnetic field due to dipole polarization of water molecules directly influences the structure of water associates formed from a variety of  $\text{H}_2\text{O}$  molecules bound to each other via a low energy intermolecular van der Waals forces, dipole-dipole interactions and hydrogen bonding, which may cause the deformation of hydrogen bonds and their partial rupture, as well as the migration of mobile protons  $\text{H}^+$  within the associative elements of water and redistribution of  $\text{H}_2\text{O}$  molecules in temporary associates - clusters with general formula  $(\text{H}_2\text{O})_n$ , where n according to the recent studies can reach tens to several hundreds units (Ignatov & Mosin, 2013). These effects may in combination alter the structure of water that leads to the observed changes in its density, surface tension, viscosity, pH value, and parameters of physical and chemical processes occurring in water under the applied magnetic field, including the dissolution and crystallization of dissolved inorganic salts (Bannikov, 2004).

There is evidence of the effectiveness of magnetic water treatment in reduction of the concentration of oxygen and carbon dioxide in the magnetic treated water that is explained by the formation of metastable clathrate structures of metal cations as a hexo aqua complex of  $[\text{Ca}(\text{H}_2\text{O}_6)]^{2+}$ . The complex influence of the magnetic field on the structure of the hydrated cations of scaling salts opens up broad prospects for magnetic water treatment in power heating and related industries, including the water treatment.

There is also evidence pointing out to the bactericidal effect of the magnetic field (Solov'eva, 1974) that is essential for the use of the magnetic water treatment in systems that require a high level of microbial purity. The above mentioned factors contribute to the use of the magnetic water treatment in the power heat exchange devices and systems that are sensitive to scale - as formed on the inner walls of pipes of heat exchangers the solid deposits of hydrocarbon (calcium carbonates  $\text{Ca}(\text{HCO}_3)_2$  and magnesium carbonates  $\text{Mg}(\text{HCO}_3)_2$ , decaying to  $\text{CaCO}_3$  and  $\text{Mg}(\text{OH})_2$  when water is heated with the subsequent release of  $\text{CO}_2$ , as well as sulfate ( $\text{CaSO}_4$ ,  $\text{MgSO}_4$ ), chloride ( $\text{CaCl}_2$ ,  $\text{MgCl}_2$ ) and in less degree silicate ( $\text{SiO}_3^{2-}$ ) salts of calcium, magnesium and iron (Shterenshis, 1973). Limescale reduces the diameter of the pipelines, which leads to the increased flow resistance, which in its turn adversely affects the operation of heat exchange equipment. Since the scale has an extremely low coefficient of thermal conductivity than the metal from which the heating elements were made, water heating consumes much more time. Therefore over time, the energy losses can make the functioning of a heat exchanger on such water ineffective or even impossible. When the thickness of the inner layer of limescale increases, this lead to a violation of water circulation; in boilers this may lead to overheating of the metal and, ultimately, to its destruction. All these factors lead to the need for regular repairs, replacement of piping and plumbing and require substantial capital investments and additional financial costs to clean out the heat exchange equipment from limescale.

The magnetic water treatment compared with conventional methods of water softening by ion exchange and reverse osmosis technology is simple, economical and environmentally safe. It is effective in the treatment of calcium-carbonate waters, which make up about 80% of all natural waters of the Russian Federation and Bulgaria. That is why the scope of applying of the magnetic water treatment covers the power heating boilers, heat exchangers, boilers, compressors, engine cooling systems and generators, steam generators, network supplying hot and cold water, district heating, piping and other heat transfer equipment etc. The magnetic water treatment reduces corrosion of steel pipes and heat exchange equipment by ~30-50% (depending on the initial composition of water), which makes it possible to increase the lifetime of thermal power equipment, water pipes, and significantly reduce the accident rates (Martynova *et al.*, 1979).

Taking into account the contemporary trends and prospects of using the magnetic water treatment, it is very relevant to develop the new and to improve the existing magnetic water treatment technologies for achievement of higher efficiency and functioning of magnetic water treatment devices for a more complete extraction of the water hardness and increasing resources of heat exchange equipment. The aim of this research was to review the mechanisms of action of the magnetic field on water, the parameters occurring in water physico-chemical processes and the behavior of the dissolved in water salts.

### **The mechanism of action of the magnetic field on water**

The principle of operation of existing water softener magnetic devices is based on complex multifactorial influence of the exposed magnetic field generated by permanent magnets or electromagnets to the dissolved in water hydrated metal cations of  $\text{Ca}^{2+}$ ,  $\text{Mg}^{2+}$ ,  $\text{Fe}^{2+}$  and  $\text{Fe}^{3+}$  and the structure of the hydrates and water associates that leads to a change in the rate of electrochemical coagulation and aggregate stability (clumping and consolidation) of dispersed charged particles in a liquid stream of magnetized water and to

formation of multiple nucleation sites on the particles of fine dispersed precipitate consisting of crystals of substantially uniform size (Mosin, 2013).

In the process of the magnetic water treatment there are occurred several processes:

- The displacement by the electromagnetic field the balance between the structural components of water and the hydrated ions;
- Increase in the nucleation of dissolved salts on microinclusions of dispersed ferroparticles in a local volume of water;
- Changing in coagulation and sedimentation rates of dispersed particles in the treated by the magnetic field water flux.

As a result, magnesium and calcium salts dissolved in water lose their ability to form a dense deposits - instead of usual calcium carbonate is formed fine crystalline polymorphic  $\text{CaCO}_3$ , which on the structure resembles aragonite – a carbonate mineral with orthorhombic acicular crystals, that is either not released from the treated water as the crystal growth stops at the stage of microcrystals, or is precipitated as a fine sediment accumulating in the sump container.

Anti-scale effect under the magnetic water treatment depends on the composition of the treated water, the magnetic field strength, rate of water movement, the duration of its stay in the magnetic field and other factors. In general, anti-scale effect of the magnetic treatment of water increases with increasing temperature of the treated water; with increasing content of  $\text{Ca}^{2+}$  and  $\text{Mg}^{2+}$  cations; with an increase in the pH value of the treated water, as well as with the reducing the total salinity of water.

In theoretical calculations an individual water molecule is considered as the charged dipole. With the flow of water molecules (dipoles) in the magnetic field perpendicular to the magnetic field lines along the axis Y (the vector  $V$ ) occurs torque  $F_1$ ,  $F_2$  (Lorentz force) trying to deploy a molecule in the horizontal plane. When the dipole moves in a horizontal plane, along an Z-axis, in the vertical plane arises a torque. The magnet poles prevent rotation of the dipole molecule; therefore the movement of the dipole perpendicular to the magnetic field lines will be inhibited. This leads to the fact that for a dipole placed between the two poles of the magnet remains only one degree of freedom - the oscillation along X-axis, i.g. the oscillation along the magnetic lines of the applied field. For other coordinates the motion of  $\text{H}_2\text{O}$  dipoles is limited: they became “sandwiched” between the poles of a magnet, making an oscillatory motion about the X-axis. Certain position of the dipoles of  $\text{H}_2\text{O}$  molecules in the magnetic field along the field lines will be maintained, thereby somehow arranging their orientation in the magnetic field. These theoretical calculations are applicable to the description of the behavior in the magnetic field the hydrated metal cations  $\text{Ca}^{2+}$ ,  $\text{Mg}^{2+}$ ,  $\text{Fe}^{2+}$  and  $\text{Fe}^{3+}$ , with the difference that in the magnetic field there occurs polarization of the hydrated cation shells.

It was proved experimentally that on the fixed water the magnetic field acts much weaker, because moving in a flux water possess some electroconductivity; while its moving in the electromagnetic fields are generated small electric currents (Shchelokov, 2002). Therefore, this method of treatment of moving in a stream water is often designated by the magnetohydrodynamic treatment (MHDT). With the use of modern methods MHDT can achieve effects such those as observed at water treatment, as the increase of pH value of water (to reduce the corrosivity of water flow), creating a local increase in the concentration of ions in

the local volume of water (for the conversion of excess content of hardness ions in a finely divided crystalline phase and prevention of salts precipitation on the surface of heat exchange equipment and piping), etc. (Tebenikhin & Gusev, 1970).

Structurally, the majority of magnetic water treatment apparatus are composed of a magneto-cell manufactured in the form of a hollow cylindrical element made from ferromagnetic material with the magnets placed inside by the means of the flange or the threaded connection with the annular air gap cross sectional area, the passage area of which, however, is not smaller than the passage area of the supply and discharge piping, that does not lead to a significant drop in output pressure of the apparatus (Koshoridze & Levin, 2009). As a result of a steady laminar flow of an electrically conductive fluid (water) in the magnetodynamic cell being placed in a uniform transverse magnetic field with induction  $B_0$  (Figure 1), the Lorentz force is generated (Savelyev, 1978), the value of which depends on the charge  $q$  of the particle, its velocity  $u$  and the magnetic field  $B$ .

$$\vec{F}_\Lambda = q \cdot [\vec{u} \times \vec{B}]$$

The Lorentz force is directed perpendicular to the fluid velocity and the lines of the magnetic induction of the electromagnetic field  $B$ , whereby the ions and the charged particles in a fluid stream are moving around a circle which plane is perpendicular to the lines of the vector  $B$  (Branover & Tsinnober, 1970). Thus, by choosing the required position of the magnetic induction  $B$  with respect to the velocity vector of the liquid stream, it can be possible to purposefully affect the cations of  $Ca^{2+}$ ,  $Mg^{2+}$ ,  $Fe^{2+}$  and  $Fe^{3+}$ , redistributing them in a local volume of an aqueous medium.

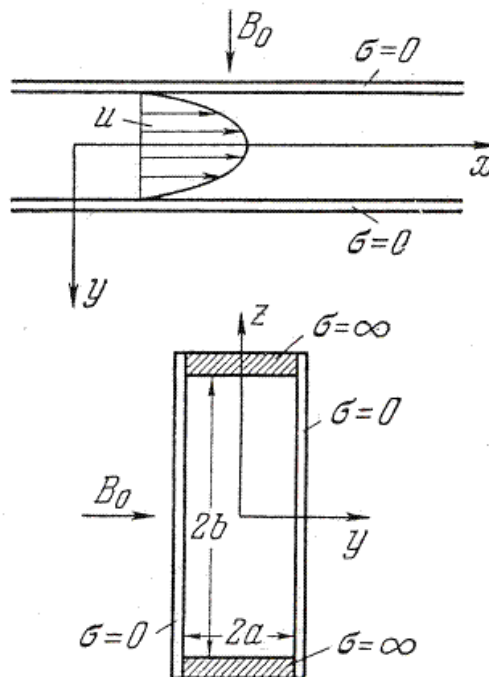

Figure 1. Diagram of flow of water in the MHD cell:  $\sigma$  - conductivity of the cell wall;  $B_0$  - amplitude value of the magnetic field induction vector.

According to theoretical calculations, to initiate crystallization of hardness salts within the local volume of the liquid (water) moving through a pipe around the walls of the pipes in the operating air gaps of the magnetic device, is applied such a direction of the magnetic induction  $B_0$ , wherein in the middle of the operating air gap is formed the zone with zero induction. For this purpose, the magnets are arranged in the device in such a way that the same magnetic poles are directed towards each other (Figure 2). In this scheme under the action of the Lorentz force in an aqueous medium there occurs a counter flow of anions and cations in the region interacting with the zero value of magnetic induction, which contributes to the creating in this zone the concentrations of interacting ions, which in its turn leads to their precipitation and subsequent formation of nucleation centers of scale-forming salts.

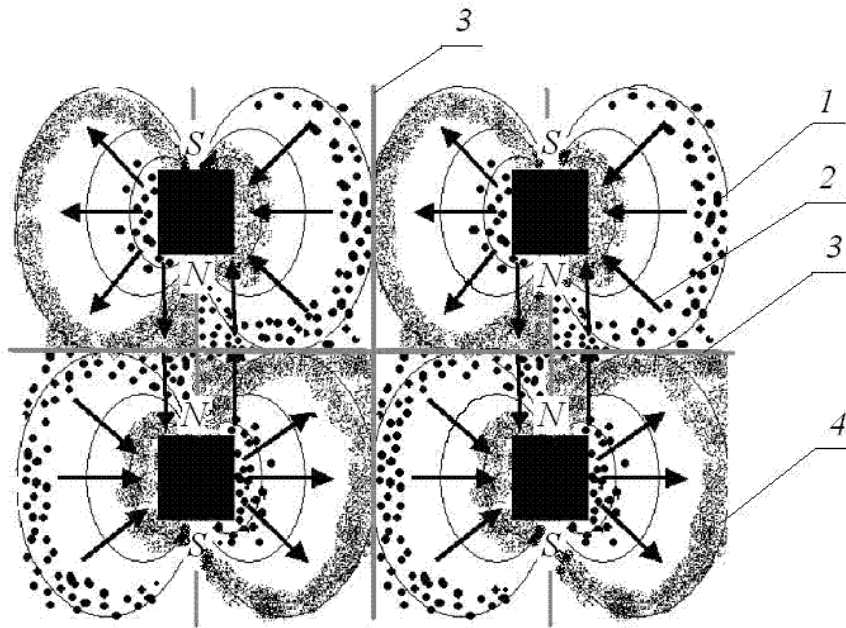

Figure 2. Scheme of layout of magnets, lines of induction, Lorentz force vectors and ions in MHD-cell. 1 - anions, 2 - the direction of the induced currents, 3 - zones with zero induction, 4 - cations.

When designing magnetic devices it need be specified the type of device performance, the amplitude of the magnetic field in the gap and the corresponding magnetic field strength, the velocity of water in the operating air gap, the passage time of water through the core unit, the composition of the ferromagnet (apparatus with electromagnets/solenoids), magnetic alloy and dimensions of the magnet (Mosin, 2012).

#### Design of magnetic water treatment devices

Domestic industry produces two types of devices for the magnetic water treatment (DMW) – based on permanent magnet made from hard magnetic ferrites (Table 1, Table. 2) and operates on AC solenoid electromagnets (Table 3) (solenoids with ferromagnets), generating an alternating magnetic field. These devices subdivided into hydromagnetic systems (HMS), magnetic transducers (hydromultipoles) - MSP, MWS, MMT and activators of water series AMP, MPAV, AIM, KEMA for domestic and industrial usage. Most of them are similar in design and principle of operation. Both these devices are mounted to the pipeline by means of threaded or flanged connections.

Installing of threaded magnetic water treatment devices is carried out in the following cases:

- If the system has a pump unit, the selection carries out on the performance of the pump;
- When setting the threaded device the distance to the object to be protected must be in a range from 1 m to 5 m;
- If there is a water meter, the unit is set up not less than 1 meter after the water meter along the flow of water;
- It is necessary to install the device in a relaxing (laminar) flow of water, i.e. before the pump or more than 15 m after it;
- If possible to set up the unit before the pump to protect it;
- To protect the device from sludge it is required to set up the device before the magnetomechanical filter;
- Selection of magnetofilter is carried out by the connection diameter;

Installation of flange magnetic water treatment devices is carried out in the following cases:

- The unit is installed at least not far from 3 meters and within 30 meters from the protected equipment;
- The unit is set up in laminar flow of water, or before the pump or more than 15 m after it;
- If possible to set the unit to the pump to protect it;
- In front of the device is set sludge filter set (not necessarily magnetomechanical);
- Selection of magnetofilter is carried out by connection diameter.

Table. 1. Specifications of domestic magnetic water treatment devices (screw connection) based on permanent magnets.

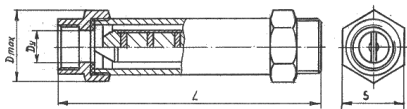

Key Features:

- Nominal diameter (mm): 10; 15; 20; 25; 32
- Nominal pressure (MPa): 1.0

Parameter	Apparatus model				
	AMP 10 PZ	AMP 15 PZ	AMP 20PZ	AMP25 PZ	AMP32 PZ
The amplitude peak value of the magnetic induction ( $B_0$ ) on the surface of the working area, mT	180.0				
The number of working areas	5.0				
Nominal water flow, min./norm./max, m <sup>3</sup> /h	0.15/0.5/0.71	0.35/1.15/1.65	0.65/1.9/2.9	1.0/3.0/4.5	1.6/4.8/7.4
Nominal diameter, mm	10	15	20	25	32
Compound, inch	1/2	1/2	3/4	1	1 <sup>1</sup> / <sub>4</sub>
Maximum working pressure, MPa	1.0				
Operating temperature range, °C	5–120				
Dimensions, (L×D <sub>y</sub> ), mm	108×32	124×34	148×41	172×50	150×56
Weight, kg	0.5	0.75	0.8	1.2	1.8

Table. 2. Specifications of domestic industrial magnetic water treatment devices (flange connection) based on permanent magnets.

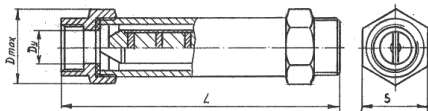

Key Features:

- Nominal diameter (mm): 32; 40; 50; 65; 80; 100; 125
- Nominal pressure (MPa): 10.0

Parameter	Apparatus model						
	AMP 32FZ	AMP 40FZ	AMP 50FZ	AMP 65FZ	AMP 80FZ	AMP 100FZ	AMP 125FZ
The amplitude peak value of the magnetic induction ( $B_0$ ) on the surface of the working area, mT	180.0						
The number of working areas	5.0						
Nominal water flow,	1.6/4.8/7.4	2.5/7.5/11.5	4.8/11.8/18	6.6/20/30.5	10/30.5/46	15.7/47/72	20/75/112.5



min./norm./max, m <sup>3</sup> /h							
Nominal diameter, mm	32	40	50	65	80	100	125
Maximum working pressure, MPa	10.0						
Operating temperature range, °C	5–120						
Dimensions, (L×D <sub>y</sub> ), mm	280×145	326×160	398×180	418×195	460×215	540×245	568×280
Weight, kg	8.0	13.5	19.0	24.0	32.0	45.0	56.0

Table. 3. Specifications of domestic magnetic water treatment devices based on the electromagnets (solenoids).

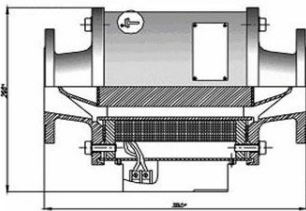

Key Features:

- Nominal diameter (mm): 80; 100; 200; 600
- Nominal pressure (MPa): 1.6

Parameter	Apparatus model			
	AMO-25UHL	AMO-100UHL	AMO-200UHL	AMO-600UHL
Voltage, V	220			
Frequency, Hz	60			
Performance for treated water m <sup>3</sup> /h	25	100	200	600
The magnetic field strength, kA/m	200			
Temperatures of water, °C	60	40	50	70
Working water pressure, MPa	1.6			
Electromagnet power consumption, kW	0.35	0.5	0.5	1.8
The dimensions of the electromagnet, mm	260×410	440×835	520×950	755×1100
Overall dimensions of the power supply, mm	250×350×250			

Electromagnet weight, kg	40	200	330	1000
Weight of power supply unit, kg	8.0			

In magnetic devices operating on electromagnets (solenoids), water is exposed by continuously adjustable influence of the magnetic field of different strength and alternating direction of the magnetic induction, wherein electromagnets can be located both inside and outside the unit. The electromagnet consists of a coil-winding and the magnetic circuit formed by the core, the rings of the coil and the casing. Between the core and the coil is formed an annular gap for the passage of an influx of the treated water. The magnetic field crosses twice the water flow in a direction perpendicular to its motion. The control unit provides a half-wave rectification of AC to DC. To install the electromagnet in the pipeline there are provided special electric adapters. The unit itself must be installed as close as possible to the protected equipment. If the system has a centrifugal pump, the magnetic treatment unit is mounted after the pump.

Table 4. Main physical parameters of rare-earth permanent magnets

Magnet composition	Residual induction, T	Magnetization, kA/m	Magnetic field energy, kJ/m <sup>3</sup>
Sm-Zr-Fe-Co-Cu	1.0-1.1	1500-2400	180-220
Nd-Fe-Co-Ti-Cu-B	1.2-1.3	1500-2400	280-320

In the constructions of the second type of magnetic devices are applied permanent magnets based on modern powdered magnetic carriers - ferromagnetic ferrite, barium and rare earth alloy magnetic materials of rare earth metals neodymium (Nd), samarium (Sm) with zirconium (Zr), iron (Fe), copper (Cu), titanium (Ti), cobalt (Co) and boron (B). Recent types on neodymium (Nd), iron (Fe), titanium (Ti) and boron (B) are preferable because they possess long service life, the magnetization 1500-2400 kA/m, a residual induction of 1.2-1.3 Tesla, the energy of the magnetic field 280-320 kJ/m<sup>3</sup> (Table 4) and do not lose their properties when heated to 150 °C.

Table. 5. Specifications of hydromagnetic systems

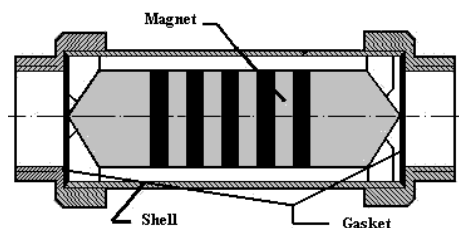

Key features:

- Nominal diameter (mm): 15; 20; 25
- Nominal pressure (MPa): 0.8

Model	Pipe diameter, mm (inch)	Nominal pressure, Mpa	Productivity, m <sup>3</sup> /h
HMS-15	15 (1/2")	0.8	1.5
HMS-20	20 (3/4")	0.8	2.0
HMS-25F	25 (1")	0.8	7.0
HMS-35F	35 (1")	0.8	20.0

The permanent magnets oriented in a certain way in a unit are arranged coaxially within the cylindrical body of the magnetic element made from stainless steel of marking 12X18H10T, which ends are provided with tapered centering tips elements connected by argon-arc welding (Mosin, 2011a). The main element of the magnetic transducer (magnetic dynamic cell) is a multi-pole magnet of cylindrical shape that creates a symmetrical magnetic field, the axial and radial components of which under the transition from one pole to another pole of the magnet change in the opposite direction. Due to the location of the magnets, creating a high-gradient magnetic field transverse with respect to the water flow, is achieved the maximum efficiency of the magnetic field on the ions of dissolved in water scale-forming salts. As a result, crystallization of scale-forming salts does not occur on the walls of the heat exchangers, but in the bulk water as a fine suspension (dredge), which is removed by blowing a stream of water in special sump collectors installed in heating systems after DMW-device, as well as in hot water magistrales. Hydromagnetic water treatment systems (HMS) are varied favorably on techno-economic characteristics. The optimal interval velocity of the water flow for HMS makes up 0.5-4.0 m/s, the optimal pressure – 0.8-1.0 MPa (Table 5) (Mosin, 2011c). Operating costs of such devices usually make up 10 years. These devices can be installed in both industrial and domestic conditions: magistral lines, feeding water into the water mains, boilers, flow heaters, steam and water boilers, water heating systems of various technological equipment (compressor stations, electric cars, and other thermal equipment). Although HMS are designed for water flow rates from 0.08 to 1100 m<sup>3</sup>/h and for the pipe's diameter of 15-325 mm, however, there have been experience in creating the magnetic devices for power plants with pipe sizes of 2000 to 4000 mm (Mosin, 2011b).

In recent time are also used the apparatus of pulsed magnetic field, the distribution of which in the space is characterized by an electric frequency modulation and pulse intervals composed of microseconds, capable of generating a strong induction at 5-100 T and superstrong magnetic fields with the the magnetic induction being more than 100 T. For this purpose are used mainly helical coils made of durable steel and bronze. For formation of superstrong constant magnetic fields with greater induction are used superconducting electromagnets (Mosin, 2012b).

Table. 6. Magnetic activators of AMV type. Household series (with screw connections)

№	Model	Capacity, m <sup>3</sup> /h		
		Minimal	Average	Maximum
1	Magnetic activator AMB D <sub>y</sub> 10	0.1	0.5	0.9
2	Magnetic activator AMB D <sub>y</sub> 15	0.2	1.35	2.5
3	Magnetic activator AMB D <sub>y</sub> 20	0.5	2.25	4.0
4	Magnetic activator AMB D <sub>y</sub> 25	1.0	4.00	7.0

Table. 6. Magnetic activators of AM type. Industrial series (with flanged connection)

№	Model	Capacity, m <sup>3</sup> /h		
		Minimal	Average	Maximum
1	Magnetic activator AMB D <sub>y</sub> 32	1.8	5.9	10.0
2	Magnetic activator AMB D <sub>y</sub> 40	2.5	7.7	13.0
3	Magnetic activator AMB D <sub>y</sub> 50	3.3	11.7	20.0
4	Magnetic activator AMB D <sub>y</sub> 65	5.0	20.0	35.0
5	Magnetic activator AMB D <sub>y</sub> 80	8.0	26.5	45.0
6	Magnetic activator AMB D <sub>y</sub> 100	12.0	51.0	90.0
7	Magnetic activator AMB D <sub>y</sub> 125	20.0	85.0	170.0
8	Magnetic activator AMB D <sub>y</sub> 150	30.0	130.0	260.0
9	Magnetic activator AMB D <sub>y</sub> 175	45.0	170.0	345.0
10	Magnetic activator AMB D <sub>y</sub> 200	55.0	215.0	435.0
11	Magnetic activator AMB D <sub>y</sub> 250	100.0	400.0	700.0

Devices based on permanent magnets are favorably differend from the magnetic devices based on electromagnets (solenoids), because during their operation there are not any problems associated with the consumption of electricity and, therefore, with the repair from electrical breakdown of electromagnet coils (Table 6, Table. 7). These devices can be installed in both industrial and domestic conditions: lines, feeding water into the water mains, boilers, water heating systems of various technological equipment. The main disadvantage of these devices is that the permanent magnets on the base of barium ferrite are demagnetized on 40-50% after 5 years. For industrial purposes it is recommended to use the magnetic devices based on electromagnets, as AMO-25UHL, AMO-100UHL, AMO-200UHL and AMO-600UHL.

When designing magnetic devices is setting up an apparatus type, its capability, the magnetic field in the operating air gap and the corresponding magnetic field strength, the velocity of water in the operating air gap, the time of passage of water, the core unit, the composition of the ferromagnet (machines with electromagnets), magnetic alloy and dimensions of the magnet (machines with permanent magnets).

Apparatus for magnetic water treatment may be used for household and industrial purposes to prevent scaling; to reduce the effect of scaling in pipes of hot and cold water magistrales, in heating elements of the

boiler equipment, heat exchangers, steam generators, cooling equipment, etc.; to prevent corrosion in pipes of local hot and cold water magistral; for purification of water (for example, after chlorination); in this case, the deposition rate of scale-forming salts is increased by 2-3 fold with sumps requiring smaller capacity; increase of the filtration systems for chemical water treatment - filtration cycle is increased by 1.5 times while reducing the consumption of chemical reagents and purification of heat exchange units (Mosin, 2011c; Mosin & Ignatov, 2014). The magnetic water treatment devices may be used alone or as part of any installations patterns of apparatus tend to scale formation during operation - water treatment systems in dwellings, cottages, children and health care facilities, water treatment in the food industry, etc. The use of these devices is the most efficient for treatment of water with a carbonate hardness predominance to 4 mg-Eq/l, and the total hardness to 6 mg-Eq/l with a total mineralization level of 500 mg/l.

Requirements regulating the working conditions of the magnetic water treatment devices consist in the following factors:

- Temperature of water heating in the apparatus should be no higher than 95 °C;
- Content of Fe<sup>2+</sup> and Fe<sup>3+</sup> ions in the treated water should be no less than 0.3 mg/l;
- The total content of sulfates and chlorides of Ca<sup>2+</sup> and Mg<sup>2+</sup> (CaSO<sub>4</sub>, CaCl<sub>2</sub>, MgSO<sub>4</sub>, MgCl<sub>2</sub>) should be not more than 50 mg/l;
- Carbonate hardness (Ca(HCO<sub>3</sub>)<sub>2</sub>, Mg(HCO<sub>3</sub>)<sub>2</sub>), - not more than 9 mEq/l;
- Content of dissolved oxygen in water - less than 3 mg/l;
- The velocity of the water flow in the apparatus - 1-3 m/s.

According to the Russian building regulation norms (SNIP 11-35-76, "Boiler"), the magnetic water treatment for thermal equipment and boilers is advisable to carry out, if the content of Fe<sup>2+</sup> and Fe<sup>3+</sup> ions in water does not exceed 0.3 mg/l, oxygen content - 3 mg/l, the constant hardness of water (CaSO<sub>4</sub>, CaCl<sub>2</sub>, MgSO<sub>4</sub>, MgCl<sub>2</sub>) - 50 mg/l, carbonate hardness (Ca(HCO<sub>3</sub>)<sub>2</sub>, Mg(HCO<sub>3</sub>)<sub>2</sub>) is not greater than 9 mEq/l and the water heating temperature must not exceed 95 °C. For power boilers and cast iron sectional boilers the using of the magnetic water treatment technology is possible if the carbonate hardness is less than 10 mEq/l, the content of Fe<sup>2+</sup> and Fe<sup>3+</sup> in water – 0.3 mg/l, on condition that water enters from the tap or surface source. Some productions, however, establish more stringent regulation to the water purification, until its deep softening (0.035-0.05 mEq/l) for water-tube boilers (15-25 atm) – 0.15 mEq/l; fire-tube boilers (5-15 atm) – 0.35 mEq/l; high pressure boilers (50-100 atm) – 0.035 mEq/l.

## Conclusions

On the basis of this research can be made the following conclusions:

- The magnetic water treatment affects both an influence on the water, the mechanical impurities and scale-forming salts and ions and on the nature of the physical and chemical processes of dissolution and crystallization;
- In water exposed after magnetic treatment is possible the change of the hydration of ions, salts solubility, pH value, which results in changing the rate of corrosion processes.

Thus, magnetic water treatment causes a variety of related physical and chemical effects. Indisputable advantages of magnetic treatment in contrast to the traditional schemes of water softening by using ion

exchange and reverse osmosis is the simplicity of the technological scheme, environment safety and economy. Besides magnetic water treatment method requires no chemical reagents, and is therefore environmentally friendly.

### References:

- Bannikov, V.V. (2004) Electromagnetic water treatment. *Ekologiya proizvodstva*, 4: 25–32 [in Russian].
- Branover, G.G. & Tsinnober, A.B. (1970) Magnetohydrodynamics of incompressible media. Moscow: Nauka, 380 p. [in Russian].
- Chesnokova, L.N. (1971) Theory and Practice of Magnetic Water Treatment and Water Systems. Moscow: Tsvetmetinformatsiya, 75 p. [in Russian].
- Ignatov, I. (2005) Energy Biomedicine, *Gea-Libris*, Sofia: 1–88.
- Ignatov, I. & Mosin, O.V. (2013) Structural Mathematical Models Describing Water Clusters. *Journal of Mathematical Theory and Modeling*, 3(11): 72–87.
- Ignatov, I. & Mosin, O.V. (2014) Mathematical Models of Distribution of Water Molecules Regarding Energies of Hydrogen Bonds, *Journal of Medicine, Physiology and Biophysics*, 2: 71-94.
- Ignatov, I. & Mosin, O.V. (2014) Mathematical Models Describing Water Clusters as Interaction among Water Molecules. Distributions of Energies of Hydrogen Bonds, *Journal of Medicine, Physiology and Biophysics*, 3: 48-70.
- Ignatov, I. & Mosin, O. V. (2014) Nature of Hydrogen Bonds in Liquids and Crystals. Ice Crystal Modifications and Their Physical Characteristics, *Journal of Medicine, Physiology and Biophysics*, 4: 58-80.
- Ignatov, I. & Mosin, O. V. (2014) The Methods for Studying the Structure of Water Clusters (H<sub>2</sub>O), where n=3-20. Water Clusters as Nano-structures, *Journal of Health, Medicine and Nursing*, 8: 29-58.
- Klassen, V.I. (1978) Magnetization of Water Systems, Moscow: Chemistry, 45 p. [in Russian].
- Krechetov, G.A. (1984) Thermodynamics of Ionic Processes in Solutions, 2<sup>nd</sup> Ed., Leningrad: Nauka, 125 p. [in Russian].
- Kronenberg, K. (1985) Experimental evidence for the effects of magnetic fields on moving water. *IEEE Transactions on Magnetics (Institute of Electrical and Electronics Engineers, Inc.)*, 21(5): 2059–2061.
- Koshoridze, S.I. & Levin, Yu.K. (2009) Physical model reduction of scale formation in magnetic water treatment in thermal power devices. *Teploenergetika*, 4: 66–68 [in Russian].
- Martynova, O. I., Gusev, B.T. & Leontyev, Ye.A. (1969) On the mechanism of the influence of magnetic field on aqueous solutions of salts. *Uspekhi fizicheskikh nauk*, 98: 25–31 [in Russian].
- Martynova, O.I., Kopylov, A.S., Terebenikhin, U.F. & Ochkov, V.F. (1979) The mechanism of influence of magnetic treatment on the processes of scaling and corrosion. *Teploenergetika*, 6: 34–36 [in Russian].
- Mosin, O.V. (2011a) Magnetic water treatment systems. Key perspectives and directions. *Santekhnika, ABOK Press, Moscow*, 1: 21–25 [in Russian].
- Mosin, O.V. (2011b) Magnetic devices for water treatment. *C.O.K. Publishing House "Media Technology" (Moscow)*, 6: 24–27 [in Russian].
- Mosin, O.V. (2011c) Prospects and directions of magnetic water treatment. *Energoberezheniye i*

*vodopodgotovka*, 5: 29-32 [in Russian].

Mosin, O.V. (2012a) Magnetic water treatment apparatus. *Novosti teplosnabzheniya*, 11: 42-47. ISSN 1609-4638 [in Russian].

Mosin, O.V. (2012b) Modern technologies and equipment for magnetic water treatment (review). Water supply and sanitary engineering. *Water supply and sanitary technique*, 8: 28-36.

Mosin, O.V. (2013) Magnetic water treatment in power heat industry. *Voda i vodoochistnye tekhnologii*, 1(11)-4(10): 12-26 [in Russian].

Mosin, O.V. & Ignatov, I. (2014) Design features of magnetohydrodynamic cell for magnetic water treatment at preparation of cement mixes. *Novye stroitelnye tekhnologii XX*, 6: 17-21 [in Russian].

Ochkov, V.F. (2006) Magnetic water treatment: history and current status. *Energoberezheniye i vodopodgotovka*, 2: 23–29 [in Russian].

Mosin, O.V. & Ignatov, I. (2014) Basic Concept of Magnetic Water Treatment, *European Journal of Molecular Biotechnology*, 4 (2): 72-85.

Savelyev, I.V. (1978) General physics course, Volume 2, Electricity and Magnetism. Wave. Optics. Moscow: Nauka, 480 p. [in Russian].

Shterenshis, I.P. (1973) Current status of magnetic water treatment in power (review). Moscow: Atoninformenergo, 78 p. [in Russian].

Shchelokov, Ya.M. (2002) On magnetic water treatment. *Novosti teplosnabzheniya*, 8(24): 41–42 [in Russian].

Solov'eva, G.R. (1974) Prospects of application of magnetic water treatment in medicine, in: Theory and practice of magnetic water treatment and water systems. Moscow: Nauka, 112 p. [in Russian].

Tebenikhin, Ye.F. & Gusev, B.T. (1970) Water treatment magnetic field in the heat industry. Moscow: Energya, 144 p. [in Russian].

The IISTE is a pioneer in the Open-Access hosting service and academic event management. The aim of the firm is Accelerating Global Knowledge Sharing.

More information about the firm can be found on the homepage:

<http://www.iiste.org>

## CALL FOR JOURNAL PAPERS

There are more than 30 peer-reviewed academic journals hosted under the hosting platform.

**Prospective authors of journals can find the submission instruction on the following page:** <http://www.iiste.org/journals/> All the journals articles are available online to the readers all over the world without financial, legal, or technical barriers other than those inseparable from gaining access to the internet itself. Paper version of the journals is also available upon request of readers and authors.

## MORE RESOURCES

Book publication information: <http://www.iiste.org/book/>

Academic conference: <http://www.iiste.org/conference/upcoming-conferences-call-for-paper/>

## IISTE Knowledge Sharing Partners

EBSCO, Index Copernicus, Ulrich's Periodicals Directory, JournalTOCS, PKP Open Archives Harvester, Bielefeld Academic Search Engine, Elektronische Zeitschriftenbibliothek EZB, Open J-Gate, OCLC WorldCat, Universe Digital Library, NewJour, Google Scholar

