

Analysis & Design of Active RFID Tag

Ms.Prachi Ramesh Patil

Dept. of Wireless Comm. & Computing, ABHA Gaikwad Patil College of Engineering, Nagpur,
Maharashtra, India

Email: pracheepatil27@gmail.com

Mrs.Pragati Patil Bedekar

Dept of .Wireless Comm & Computing ABHA Gaikwad Patil College of Engineering
Nagpur, Maharashtra, India

Abstract

The Active Radio Frequency Identification tag that is RFID tag with battery is promising solution for low power consumption and precise localization in indoor as well as for outdoor environment. In this paper, Design and Implementation of an Active RFID tag is proposed with capability of far reading distance, high reliability, low cost, low power consumption and long life. The Active RFID tag is a transmitter designed using the AVR ATmega16 microcontroller and wireless data transmission chip CC2500. The objective of tag is achieved by optimization of the circuit design for continuous Tag ID transmission of each Tag has its unique ID. The transmitted Tag ID is captured by receiver referred as RFID reader, the hardware and software implementation are presented in this paper with measurement in a typical indoor environment.

Keywords— RFID, Low Cost, Active Tag, Short Range Communication

I. INTRODUCTION

As a new kind of automatic identification technology, radio frequency identification (RFID) is the fundamental principle to realize the automatic recognition of the static or moving objects by radio frequency signal. Usually, RF system consists of RF tag, reader and host. RFID tag can be roughly classified into passive and active types of tags. The passive tag does not incorporate a battery and responds with the energy provided by a reader/writer [5] [6].

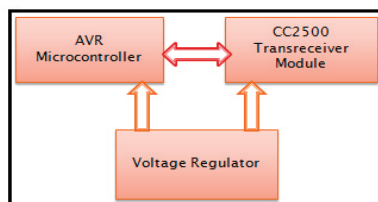

Fig(1) Active RFID Module

Also in passive tag system communication range is short, but the cost is low. This type of tags are expected to be applied to improve efficiencies in the area of the cash register, picking work at a delivery center, inventory control, and distribution / traceability. Whereas active tag's communication range is long, but coverage of application is limited because of its cost. Both passive and active types of tags are being used in various fields as per requirement. At present, most RFID systems adopt passive tags which get power from the reader by RF signal it is beneficial to reduce the label size and cost, but the reading range and data storage capacity are limited. While the active tag with battery can provide larger range of reading ability and higher reliability. Now the breakthrough of low power consumed IC technology create favorable conditions for the development of small size and low power active tag. Active tag is designed using Single-chip MSP430F2012 and wireless data transmission chip CC1100 as presented in reference [5] and using 8051 μ C and RF module which uses CC2500 chip. The active tag always transmits ID at constant intervals; the design aimed to implement active tags based on 8051 μ C and RF module having on chip antenna for wireless data transmission with the lowest possible hardware cost but has low execution speed.

II. DESIGN OF ACTIVE RFID TAG

The Active RFID tag is a transmitter designed using the AVR Amega 16 and RF module which uses CC2500 chip for wireless data transmission. Since an active RFID tag uses the battery as power supply. Our aim is for low power consumption performance to prolong the service life of battery. Low-power design requires both proper choice of components and optimized reasonable run timing during operation.

A. Selection of Microcontroller

In this the μC performing two important functions i.e. (a) store the unique ID which is referred as tag ID (b)continuously transmit tag ID for further wireless transmission. Another name for a μC , therefore, is “embedded controller”. For instance, a typical μC will have a built in clock generator and a small amount of RAM and ROM (or EPROM or EEPROM), meaning that to make it work, all that is needed is some control software and a timing crystal (through some even have internal RC clocks).

Micro-controller will also usually have a variety of input/output devices, UARTs or specialized serial communications interfaces like IC, Serial Peripheral Interface. Often these integrated devices can be controlled by specialized processor instructions. μC 's are dedicated to one task and run one specific program is stored in ROM (Read Only Memory). The program is prepared in assembly/embedded C language for performing the above functions. Finally, it must be mentioned that some Micro-controller architectures are available from many different vendors in so many varieties that they could rightly belong to a category of their own. For the required application we are using ATmega16. The ATmega16 is a low-power CMOS 8-bit microcontroller based on the AVR enhanced RISC architecture. By executing powerful instructions in a single clock cycle, the ATmega16 achieves throughputs approaching 1 MIPS per MHz allowing us to optimize power consumption versus processing speed.

B. Selection of RF chip

Choosing RF chip is the most crucial part of the Active RFID card, it directly related to tags read range and reliability, but also the power consumption. Wireless transmitter CC2500 [7] with small size, low consumption, supports programmable control; with internal address decoder, modulate processor and so on, is very easy to use. In our design we select CC2500 with operating frequency of 2.4GHz. CC2500 have on chip antenna. [5]

Features of RF module:

- 2.4 GHz carrier frequency.
- 255 possible channels.
- RS232 UART interface with variable baud rate.
- Standard configuration baud rate 9600 bps.
- Power LED indicator.
- Input Supply 5V to 12V.
- 2 run mode: Packet Mode and Single Byte Transfer.
- Variable packet length (0 to 40).
- Programmable channels (0 to 255).
- Programmable device address: 255 per channel.
- Compact size, plug and play.
- On board EEPROM for saving settings.
- Supported Baud Rate 300, 600, 1200, 2400, 4800, 9600 bps.

C. Battery supply

Battery is used as power supply directly. It saves quiescent current brought from voltage regulator circuit prolongs the service life of battery. To adopt battery as power supply, the key point is to solve the random wrong operation because of incomplete reset, which resulted from mechanical contact with the battery wires will produce power supply noise when replace the battery.

III. HARDWARE DESIGN OF ACTIVE TAG

The active tag should have the following characteristics: miniaturization, low cost, high reliability, adjustable reading, distance battery-powered, and so on. The block diagram of the tag is shown in Fig. 2.

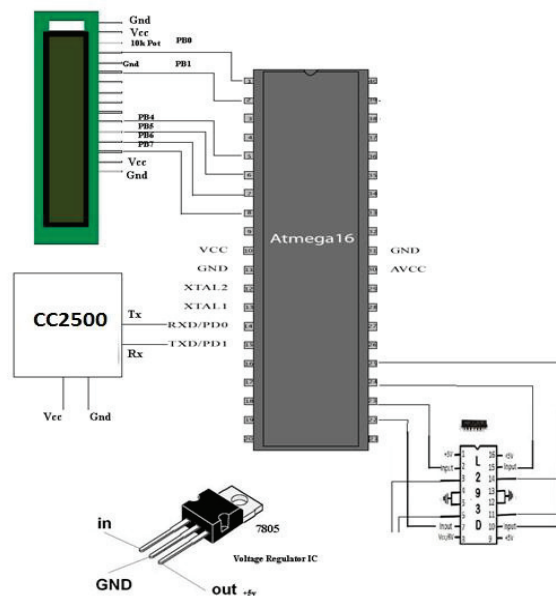

Fig.2.Circuit Diagram of RF System

A. System Structure of Tag

RFID tag consists of μ C unit, radio frequency transceiver unit, a LCD and power supply unit. Of these, the μ C unit with its own memory, which is responsible for the operation of RFID tag, data deposition and processing. The radio transceiver unit contains RF chip with on chip antenna, to achieve information transmission between active tag and reader. LCD is used to display the 12 digit ID received .The power supply unit supply power for tag.

B. Serial Communication

μ C supports four modes of serial Communication. Here we are using μ C in continuous Transmission mode.8-bit UART (Universal asynchronous receiver transmitter) with variable baud rate.

IV. SOFTWARE DESIGN OF TAG

A. Design of Workflow

Recent μ C's integrated with on-chip debug circuit accessed by In-circuit Emulator enables a programmer to debug the software of an embedded system with a debugger. The software development of system uses C language on Embedded Workbench keil to program. The intercommunication between μ C and RF module is done by using RS232 cable.

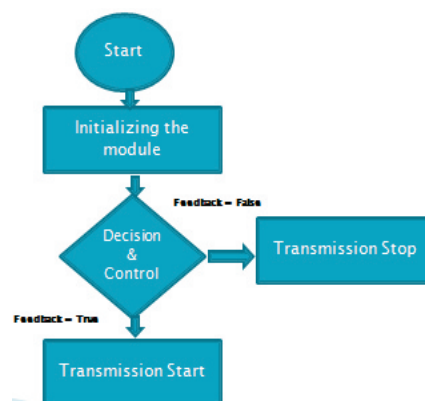

Fig3.(a)Flowchart for Tag Authentication

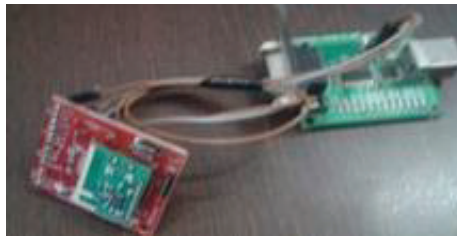

Fig.5(b) Image of working Module of Active RFID Module to be interfaced with PC

VII. CONCLUSIONS

In this paper the active RFID tags are designed and implemented successfully. Results of hardware test for prototype active tag read system are presented. The tag Solved identification problems as long-distance, big flow, anti-interference, high-speed and at the low cost. RFID tags. Tags can be used for persons or goods recognition, Management and location system, which is widely used in industrial production, national defense security and so on

REFERENCES

- [1] Adnan Abu-Mahfouz and Gerhard P. Hancke "Distance Bounding: A Practical Security Solution for Real-Time Location Systems" IEEE TRANSACTIONS ON INDUSTRIAL INFORMATICS, VOL. 9, NO. 1, FEBRUARY 2013
- [2] S. S. Saad and Z. S. Nakadv, "A standalone RFID indoor positioning system using passive tags," IEEE Trans. Ind. Electron., vol. 58, no. 5, pp.1961–1970, Jul. 2010
- [3] M. Henseler, M. Rossberg, and G. Schaefer, "Credential management for automatic identification solutions in supply chain management," IEEE Trans. Ind. Inf., vol. 4, no. 4, pp. 303–314, Nov. 2008.
- [4] Su Yu-na, Xu Yan-ping, "Design and Implementation of a Novel Active Low-Power RFID Tag", ISBN, August 2010, pp. 249-252
- [5] Deva Seetharam and Richard Fletcher TagSense Inc. 432 Columbia St, B13B, Cambridge, MA 02141 "Battery-Powered RFID"
- [6] Comparison of Wireless Indoor Positioning Technologies, An Ekahau Whitepaper, Ekahau Inc. 2000-2005
- [7] CC2500 Low-Cost Low-Power 2.4GHz RF-Transceiver, Data sheet.

The IISTE is a pioneer in the Open-Access hosting service and academic event management. The aim of the firm is Accelerating Global Knowledge Sharing.

More information about the firm can be found on the homepage:
<http://www.iiste.org>

CALL FOR JOURNAL PAPERS

There are more than 30 peer-reviewed academic journals hosted under the hosting platform.

Prospective authors of journals can find the submission instruction on the following page: <http://www.iiste.org/journals/> All the journals articles are available online to the readers all over the world without financial, legal, or technical barriers other than those inseparable from gaining access to the internet itself. Paper version of the journals is also available upon request of readers and authors.

MORE RESOURCES

Book publication information: <http://www.iiste.org/book/>

Recent conferences: <http://www.iiste.org/conference/>

IISTE Knowledge Sharing Partners

EBSCO, Index Copernicus, Ulrich's Periodicals Directory, JournalTOCS, PKP Open Archives Harvester, Bielefeld Academic Search Engine, Elektronische Zeitschriftenbibliothek EZB, Open J-Gate, OCLC WorldCat, Universe Digital Library, NewJour, Google Scholar

